

WIRING SYSTEM SECTION

WIRING SYSTEM

WI

This service manual has been prepared to provide SUBARU service personnel with the necessary information and data for the correct maintenance and repair of SUBARU vehicles.

This manual includes the procedures for maintenance, disassembling, reassembling, inspection and adjustment of components and diagnostics for guidance of experienced mechanics.

Please peruse and utilize this manual fully to ensure complete repair work for satisfying our customers by keeping their vehicle in optimum condition. When replacement of parts during repair work is needed, be sure to use SUBARU genuine parts.

All information, illustration and specifications contained in this manual are based on the latest product information available at the time of publication approval.



WIRING SYSTEM



	Page
1. Basic Diagnostics Procedure	3
2. Working Precautions	12
3. Super Multiple Junction (SMJ)	13
4. Power Supply Routing.....	15
5. Ground Distribution	22
6. Airbag System.....	31
7. Air Conditioning System.....	34
8. Anti-lock Brake System.....	36
9. A/T Control System.....	39
10. A/T Shift Lock Control System	50
11. Audio System	52
12. Charging System.....	54
13. Clock System	55
14. Combination Meter.....	56
15. Compass Mirror System.....	60
16. Cruise Control System	61
17. Door Lock System.....	64
18. Engine Coolant Temperature Gauge System	65
19. Engine Electrical System	66
20. Fuel Gauge System	87
21. Front Accessory Power Supply System	88
22. Horn System	89
23. Keyless Entry System	90
24. Back-up Light System	93
25. Clearance Light and Illumination Light System	94
26. Front Fog Light System.....	97
27. Headlight System	98
28. In Compartment Light System.....	101
29. Stop Light System	103
30. Turn Signal Light and Hazard Light System.....	104
31. Oil Pressure Warning Light System	106
32. Outside Temperature Display System	107
33. Parking Brake and Brake Fluid Level Warning System	108
34. Power Window System	109
35. Radiator Fan System	113
36. Rear Accessory Power Supply System.....	116
37. Rear Window Defogger System.....	117
38. Remote Controlled Rearview Mirror System.....	118
39. Seat Belt Warning and Key Warning System.....	119
40. Seat Heater System	120
41. Security System	121
42. Starter System	124
43. Wiper and Washer System (Front).....	127

WIRING SYSTEM

44.	Wiper and Washer System (Rear)	128
45.	Overall Systems	129
46.	Front Wiring Harness	130
47.	Bulkhead Wiring Harness (In Engine Room)	132
48.	Bulkhead Wiring Harness (In Compartment)	136
49.	Engine Wiring Harness and Transmission Cord	139
50.	Instrument Panel Wiring Harness	143
51.	Rear Wiring Harness, Bulkhead wiring Harness, Roof Cord and Fuel Tank Cord	144
52.	Door Cord.....	146
53.	Rear Wiring Harness and Trunk Lid Cord	148
54.	Rear Wiring Harness and Rear Gate Cord	150

1. Basic Diagnostics Procedure

A: BASIC PROCEDURES

1. GENERAL

The most important purpose of diagnostics is to determine which part is malfunctioning quickly, to save time and labor.

2. IDENTIFICATION OF TROUBLE SYMPTOM

Determine what the problem is based on the symptom.

3. PROBABLE CAUSE OF TROUBLE

Look at the wiring diagram and check the system's circuit. Then check the switch, relay, fuse, ground, etc.

4. LOCATION AND REPAIR OF TROUBLE

- 1) Using the diagnostics narrow down the causes.
- 2) If necessary, use a voltmeter, ohmmeter, etc.
- 3) Before replacing certain component parts (switch, relay, etc.), check the power supply, ground, for open wiring harness, poor connectors, etc. If no problems are encountered, check the component parts.

5. CONFIRMATION OF SYSTEM OPERATION

After repairing, ensure that the system operates properly.

B: BASIC INSPECTION

1. VOLTAGE MEASUREMENT

- 1) Using a voltmeter, connect the negative lead to a good ground point or negative battery terminal and the positive lead to the connector or component terminal.
- 2) Contact the positive probe of the voltmeter on connector (A). The voltmeter will indicate a voltage.
- 3) Shift the positive probe to connector (B). The voltmeter will indicate no voltage.

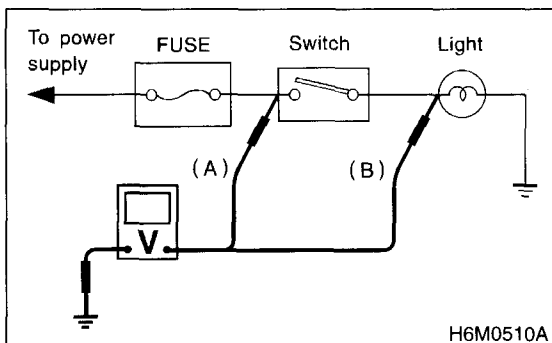

- 4) With the test set-up held as it is, turn the switch ON. The voltmeter will indicate a voltage and, at the same time, the light will come on.
- 5) The circuit is in good order. If a problem such as a lamp failing to light occurs, use the procedures outlined above to track down the malfunction.

2. CIRCUIT CONTINUITY CHECKS

- 1) Disconnect the battery terminal or connector so there is no voltage between the check points. Contact the two leads of an ohmmeter to each of the check points. If the circuit has diodes, reverse the two leads and check again.
- 2) Use an ohmmeter to check for diode continuity. When contacting the negative lead to the diode positive side and the positive lead to the negative side, there should be continuity. When contacting the two leads in reverse, there should be no continuity.

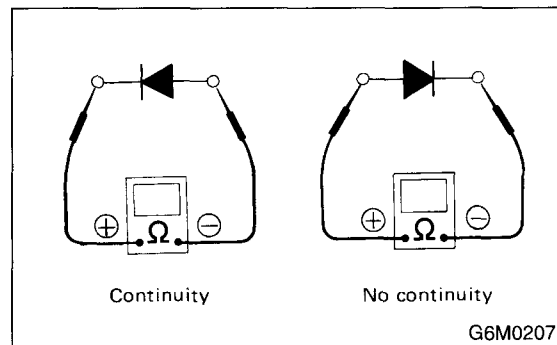

- 3) Symbol "○—○" indicates that continuity exists between two points or terminals. For example, when a switch position is at "3", continuity exists among terminals 1, 3 and 6, as shown in the table below.

Terminal	1	2	3	4	5	6
Switch Position						
OFF						
1	○—○				○—○	
2	○—○			○—○		○—○
3	○—○		○—○			○—○
4	○—○					○—○

B6M0749

BASIC DIAGNOSTICS PROCEDURE

WIRING SYSTEM

3. HOW TO DETERMINE AN OPEN CIRCUIT

1) Voltmeter Method:

An open circuit is determined by measuring the voltage between respective connectors and ground using a voltmeter, starting with the connector closest to the power supply. The power supply must be turned ON so that current flows in the circuit. If voltage is not present between a particular connector and ground, the circuit between that connector and the previous connector is open.

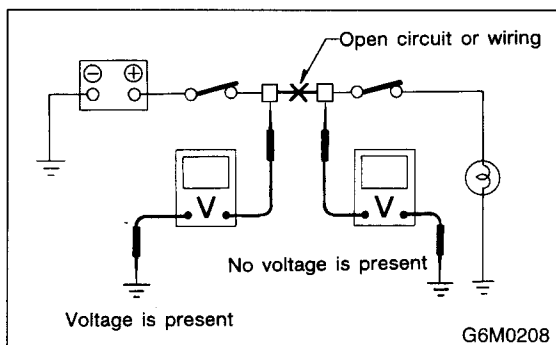

2) Ohmmeter method:

Disconnect all connectors affected, and check continuity in the wiring between adjacent connectors. When the ohmmeter indicates "infinite", the wiring is open.

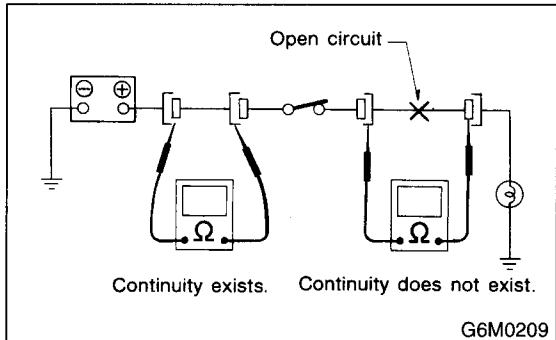

4. HOW TO DETERMINE A SHORT CIRCUIT

1) Test lamp method:

Connect a test lamp (rated at approximately 3 watts) in place of the blown fuse and allow current to flow through the circuit. Disconnect one connector at a time from the circuit, starting with the one located farthest from the power supply. If the test lamp goes out when a connector is disconnected, the wiring between that connection and the next connector (farther from the power supply) is shorted.

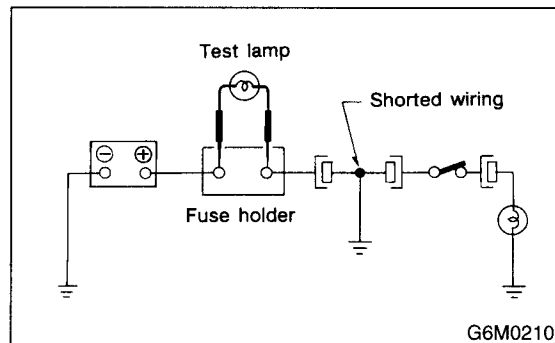

2) Ohmmeter method:

Disconnect all affected connectors, and check continuity between each connector and ground. When the ohmmeter indicates continuity between a particular connector and ground, that connector is shorted.

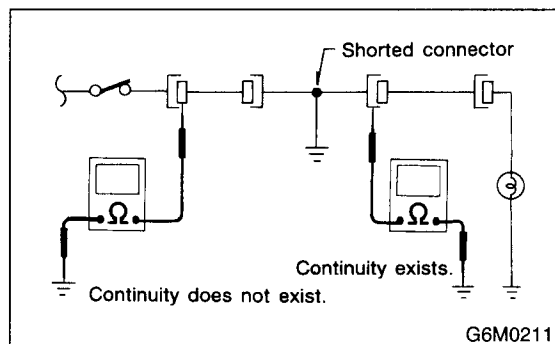

C: HOW TO READ WIRING DIAGRAMS

1. WIRING DIAGRAM

The wiring diagram of each system is illustrated so that you can understand the path through which the electric current flows from the battery.

Sketches and codes are used in the diagrams. They should read as follows:

- Each connector and its terminal position are indicated by a sketch of the connector in a disconnected state which is viewed from the front.

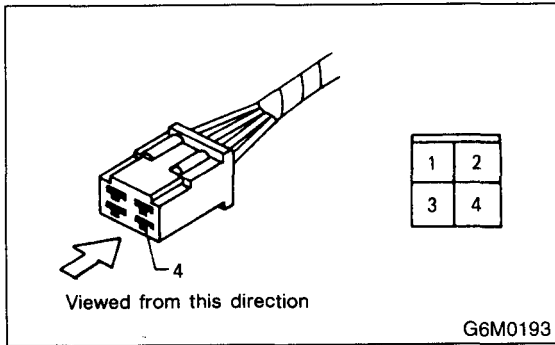

- The number of poles or pins, presence of a lock, and pin number of each terminal are indicated in the sketch of each connector. In the sketch, the highest pole number refers to the number of poles which the connector has. For example, the sketch of the connector shown in figure indicates the connector has 9 poles.

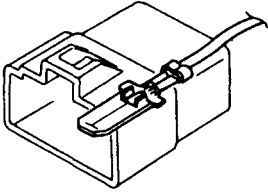
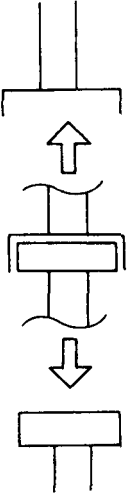
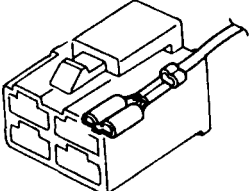
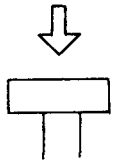
Connector used in vehicle	Connector shown in wiring diagram		
	Sketch	Symbol	Number of poles
 G6M0194	 G6M0196		Numbered in order from upper right to lower left.
 G6M0195	 G6M0197		Numbered in order from upper left to lower right.

BASIC DIAGNOSTICS PROCEDURE

WIRING SYSTEM

- When one set of connectors is viewed from the front side, the pole numbers of one connector are symmetrical to those of the other. When these two connectors are connected as a unit, the poles which have the same number are joined.

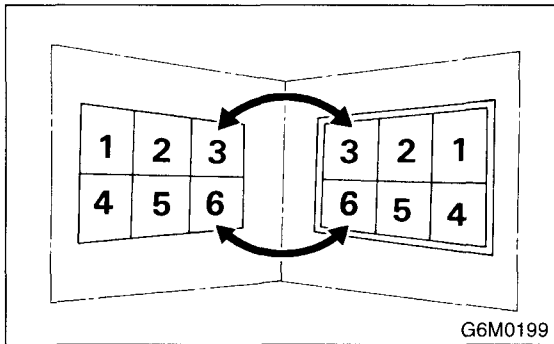

- Electrical wiring harness:**
The connectors are numbered along with the number of poles, external colors, and mating connections in the accompanying list.
- The sketch of each connector in the wiring diagram usually shows the (A) side of the connector. The relationship between the wire color, terminal number and connector is described in the figure.

NOTE:

A wire which runs in one direction from a connector terminal sometimes may have a different color from that which runs in the other direction from that terminal.

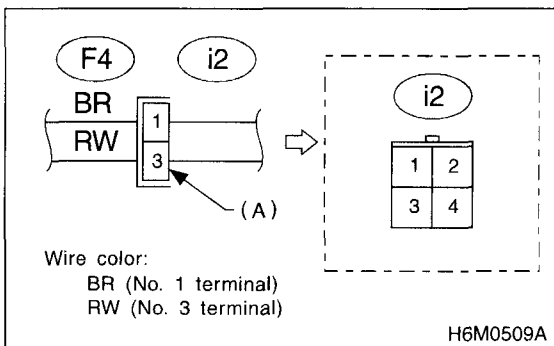

- In the wiring diagram, connectors which have no terminal number refer to one-pole types. Sketches of these connectors are omitted intentionally.

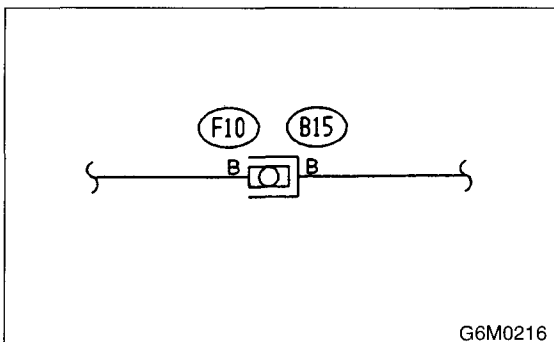

- The following color codes are used to indicate the colors of the wires used.

Color code	Color
L	Blue
B	Black
Y	Yellow
G	Green
R	Red
W	White
Br	Brown
Lg	Light green
Gr	Gray
P	Pink
Or	Orange
Lb	Light Blue
V	Violet
SA	Sealed (Inner)
SB	Sealed (Outer)

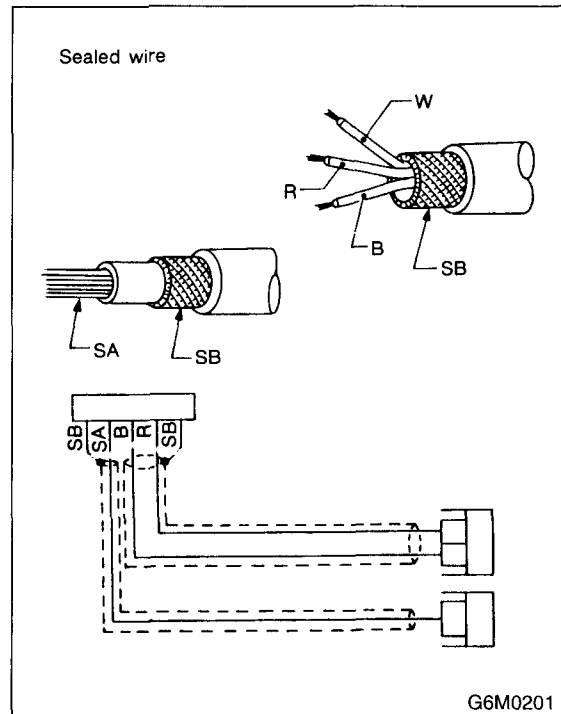

- The wire color code, which consists of two letters (or three letters including Br or Lg), indicates the standard color (base color of the wire covering) by its first letter and the stripe marking by its second letter.

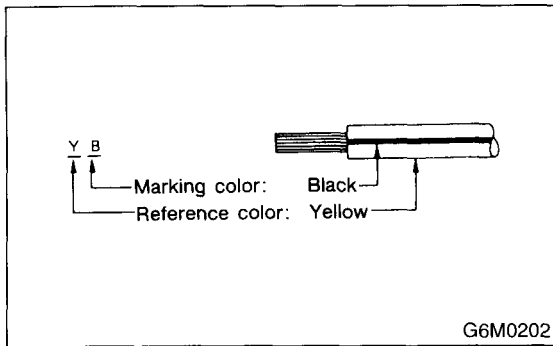

- The table lists the nominal sectional areas and allowable currents of the wires.

CAUTION:

When replacing or repairing a wire, be sure to use the same size and type of the wire which was originally used.

NOTE:

- The allowable current in the table indicates the tolerable amperage of each wire at an ambient temperature of 40°C (104°F).
- The allowable current changes with ambient temperature. Also, it changes if a bundle of more than two wires is used.

Nominal sectional area mm ²	No. of strands/ strand diameter	Outside diameter of finished wiring mm	Allowable current Amps/ 40°C (104°F)
0.3	7/0.26	1.8	7
0.5	7/0.32	2.2 (or 2.0)	12
0.75	30/0.18	2.6 (or 2.4)	16
0.85	11/0.32	2.4 (or 2.2)	16
1.25	16/0.32	2.7 (or 2.5)	21
2	26/0.32	3.1 (or 2.9)	28
3	41/0.32	3.8 (or 3.6)	38
5	65/0.32	4.6 (or 4.4)	51
8	50/0.45	5.5	67

- Each unit is directly grounded to the body or indirectly grounds through a harness ground terminal. Different symbols are used in the wiring diagram to identify the two grounding systems.

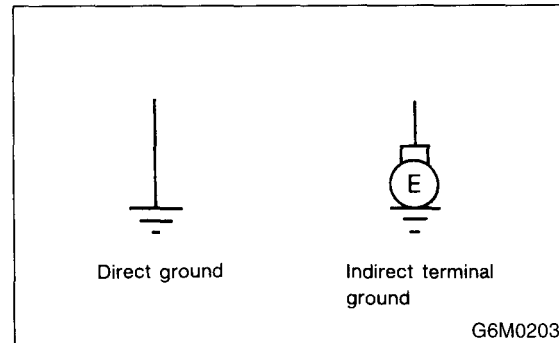

- The ground points shown in the wiring diagram refer to the following:

NOTE:

All wiring harnesses are provided with a ground point which should be securely connected.

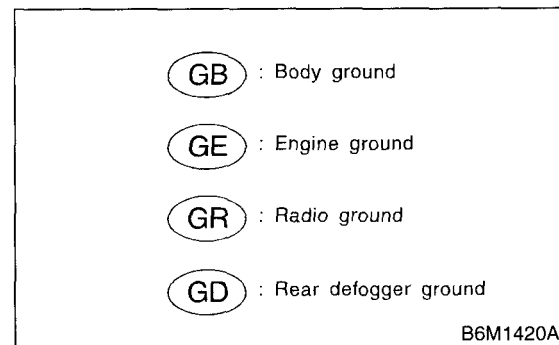

BASIC DIAGNOSTICS PROCEDURE

WIRING SYSTEM

- Relays are classified as normally-open or normally-closed. The normally-closed relay has one or more contacts.
- The wiring diagram shows the relay mode when the energizing circuit is OFF.

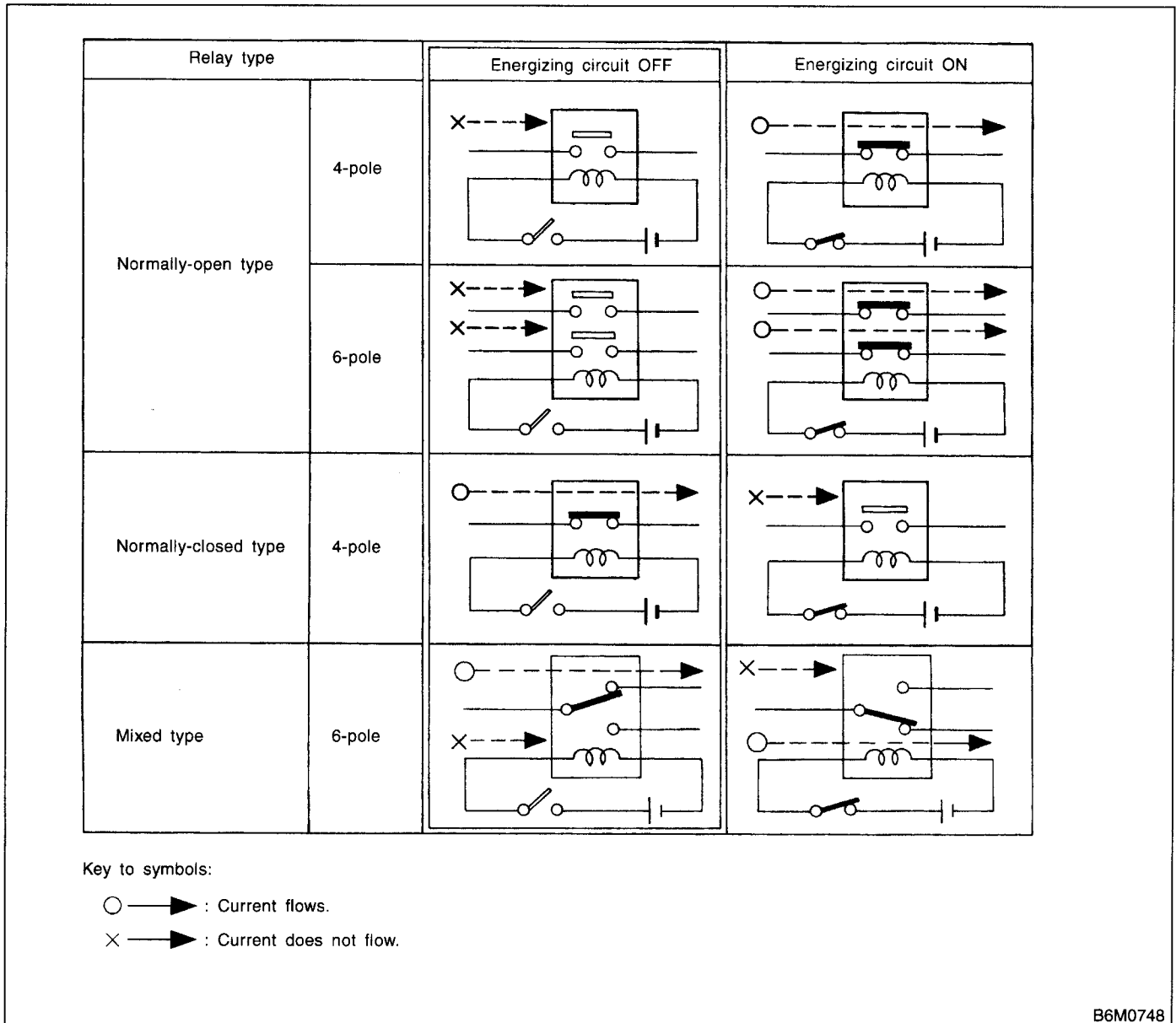

- Each connector number shown in the wiring diagram corresponds to that in the wiring harness. The location of each connector in the actual vehicle is determined by reading the first character of the connector (for example, a "F" for F8, "i" for i16, etc.) and the type of wiring harness. The first character of each connector number refers to the area or system of the vehicle.

Symbol	Wiring harness and cord
F	Front wiring harness
B	Bulkhead wiring harness
E	Engine wiring harness
T	Transmission cord, Rear oxygen sensor cord
D	Door cord LH & RH, Rear door cord LH & RH, Rear gate cord
i	Instrument panel wiring harness
R	Rear wiring harness, Fuel tank cord, Roof cord

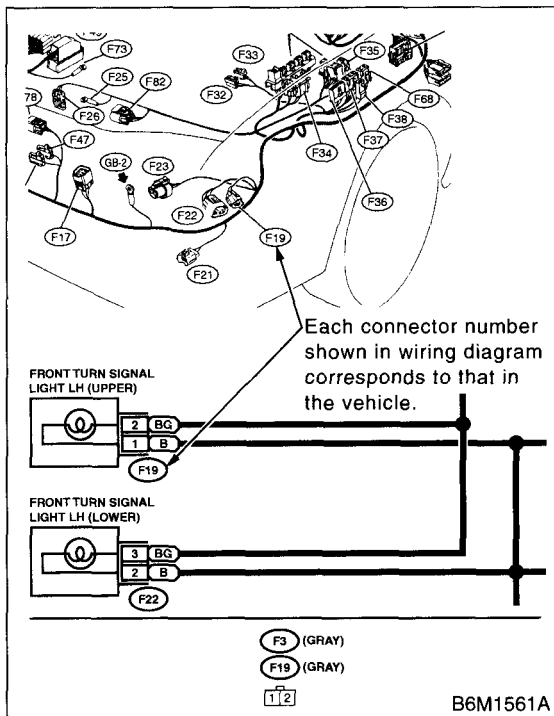

BASIC DIAGNOSTICS PROCEDURE

WIRING SYSTEM

D: SYMBOLS IN WIRING DIAGRAMS

A number of symbols are used in each wiring diagram to easily identify parts or circuits.

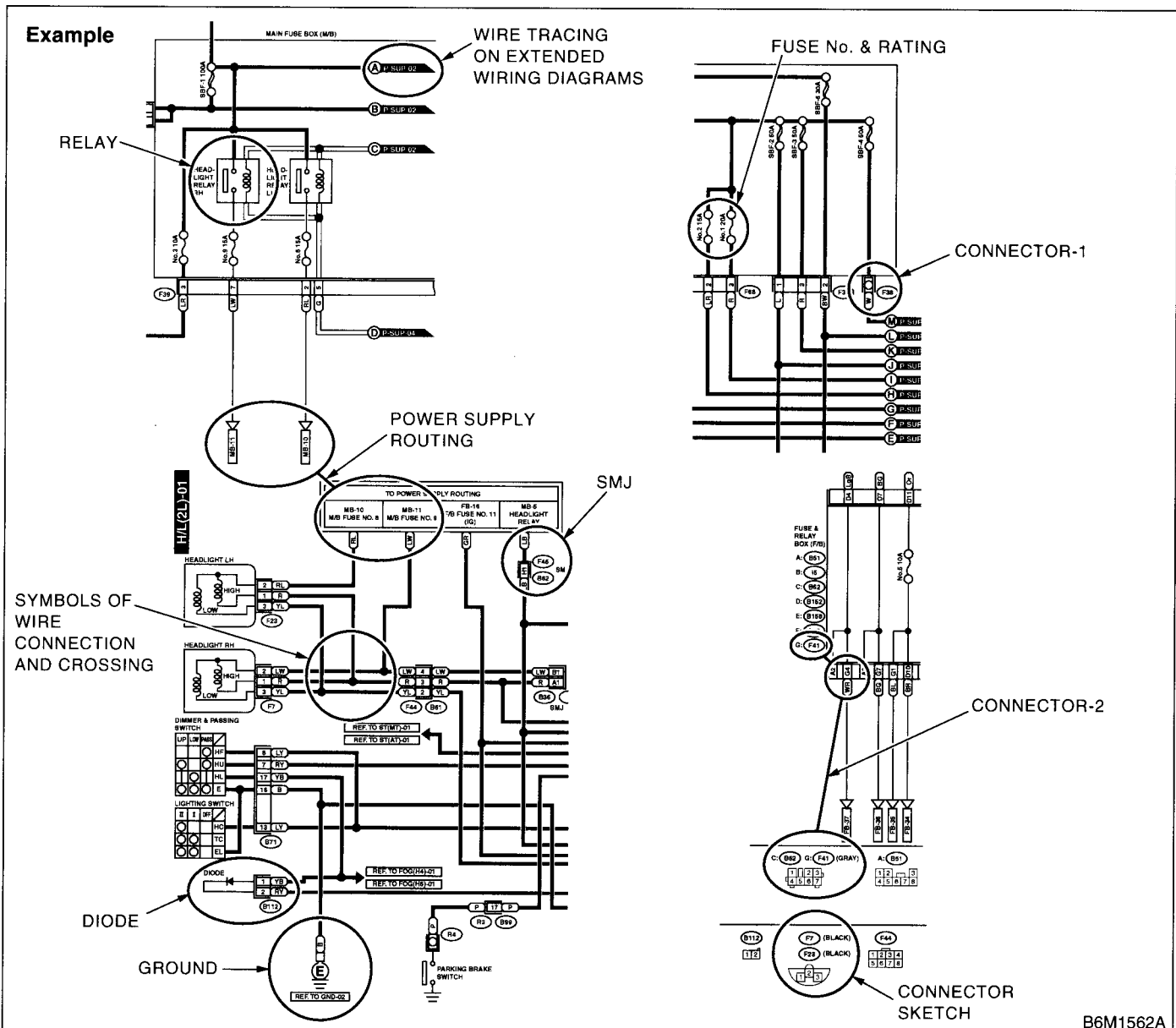

B6M1562A

1. RELAY

A symbol used to indicate a relay.

2. CONNECTOR-1

The sketch of the connector indicates the one-pole types.

3. WIRING CONNECTION

Some wiring diagrams are indicated in foldouts for convenience. Wiring destinations are indicated where necessary by corresponding symbols (as when two pages are needed for clear indication).

4. FUSE NO. & RATING

The "FUSE No. & RATING" corresponds with that used in the fuse box (main fuse box, fuse and joint box).

5. CONNECTOR-2

- Each connector is indicated by a symbol.
- Each terminal number is indicated in the corresponding wiring diagram in an abbreviated form.
- For example, terminal number "C2" refers to No. 2 terminal of connector (C: F41) shown in the connector sketch.

6. CONNECTOR SKETCH

- Each connector sketch clearly identifies the shape and color of a connector as well as terminal locations. Non-colored connectors are indicated in natural color.
- When more than two types of connector number are indicated in a connector sketch, it means that the same type connectors are used.

7. GROUND

Each grounding point can be located easily by referring to the corresponding wiring harness.

8. DIODE

A symbol is used to indicate a diode.

9. WIRE TRACING ON EXTENDED WIRING DIAGRAMS

For a wiring diagram extending over at least two pages, a symbol (consisting of the same characters with arrows), facilitates wire tracing from one page to the next.

A ↔ A, B ↔ B

10. SYMBOLS OF WIRE CONNECTION AND CROSSING

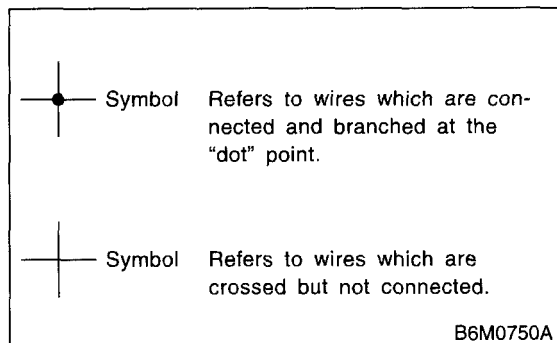

11. POWER SUPPLY ROUTING

A symbol is used to indicate the power supply in each wiring diagram.

"MB-5", "MB-6", etc., which are used as power-supply symbols throughout the text, correspond with those shown in the POWER SUPPLY ROUTING in the wiring diagram.

Accordingly, using the POWER SUPPLY ROUTING and wiring diagrams permits service personnel to understand the entire electrical arrangement of a system.

E: ABBREVIATION IN WIRING DIAGRAMS

Abbr.	Full name
ABS	Antilock Brake System
ACC	Accessory
A/C	Air Conditioning
AD	Auto Down
A/S	Air suspension
AT	Automatic Transmission
AU	Auto Up
+B	Battery
DN	Down
E	Ground
F/B	Fuse & Joint Box
FL1.5	Fusible link 1.5 mm ²
IG	Ignition
Illumi.	Illumination
LH	Left Hand
Lo	Low
M	Motor
M/B	Main Fuse Box
MG	Magnet
Mi	Middle
OP	Optional Parts
PASS	Passing
RH	Right Hand
SBF	Slow Blow Fuse
ST	Starter
SW	Switch
UP	Up
WASH	Washer

2. Working Precautions

A: PRECAUTIONS WHEN WORKING WITH THE PARTS MOUNTED ON THE VEHICLE

- 1) When working under a vehicle which is jacked-up, always be sure to use safety stands.
- 2) The parking brake must always be applied during working. Also, in automatic transmission vehicles, keep the select lever set to the P (Parking) range.
- 3) Be sure the workshop is properly ventilated when running the engine. Further, be careful not to touch the belt or fan while the engine is operating.
- 4) Be careful not to touch hot metal parts, especially the radiator and exhaust system immediately after the engine has been turned off.

B: PRECAUTIONS IN TROUBLE DIAGNOSIS AND REPAIR OF ELECTRIC PARTS

- 1) The battery cable must be disconnected from the battery's (-) terminal, and the ignition switch must be set to the OFF position, unless otherwise required by the diagnostics.
- 2) Securely fasten the wiring harness with clamps and slips so that the harness does not interfere with the body end parts or edges and bolts or screws.
- 3) When installing parts, be careful not to catch them on the wiring harness.
- 4) When disconnecting a connector, do not pull the wires, but pull while holding the connector body.

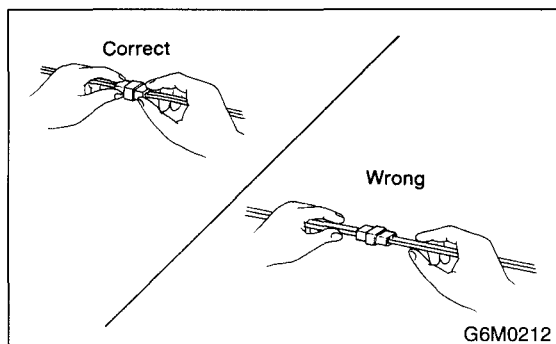

- 5) Some connectors are provided with a lock. One type of such a connector is disconnected by pushing the lock, and the other, by moving the lock up. In either type the lock shape must be identified before attempting to disconnect the connector. To connect, insert the connector until it snaps and confirm that it is tightly connected.

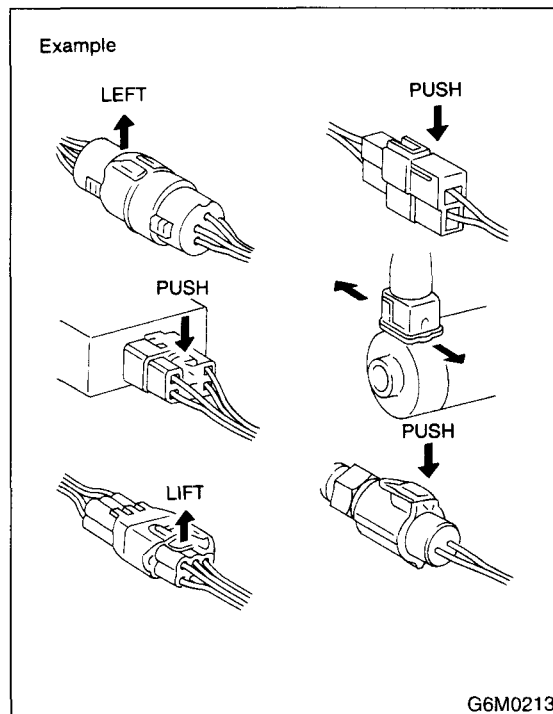

- 6) When checking continuity between connector terminals, or measuring voltage across the terminal and ground, always contact tester probe(s) on terminals from the wiring connection side. If the probe is too thick to gain access to the terminal, use "mini" test leads.

To check water-proof connectors (which are not accessible from the wiring side), contact test probes on the terminal side being careful not to bend or damage the terminals.

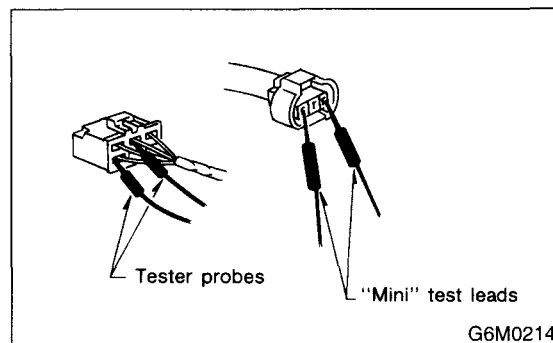

- 7) Sensors, relays, electrical unit, etc., are sensitive to strong impacts. Handle them with care so that they are not dropped or mishandled.

3. Super Multiple Junction (SMJ)

A: HOW TO USE SUPER MULTIPLE JUNCTION (SMJ)

The "SMJ" indicated in wiring diagrams is shown in a simplified form.

B: TERMINAL ARRANGEMENT

Bulkhead Wiring Harness ← → Front Wiring Harness

B209 40 Poles (Gray)

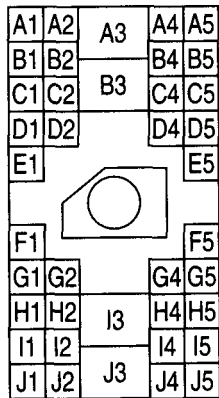

F76 40 Poles (Gray)

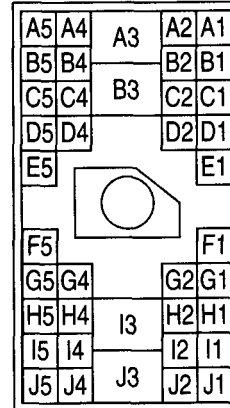

SUPER MULTIPLE JUNCTION (SMJ)

WIRING SYSTEM

C: INSTALLATION

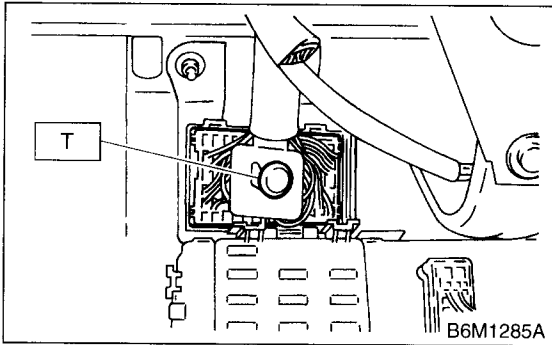

Tightening torque:

T: 4.4 N·m (0.45 kgf-m, 3.3 ft-lb)

NOTE:

- Align the cutout portion of one connector with that of other before tightening the connecting bolt.
- Do not tighten the bolt excessively since this may deform the connectors.

D: EXPLANATION OF SMJ SHOWN IN THE WIRING DIAGRAM

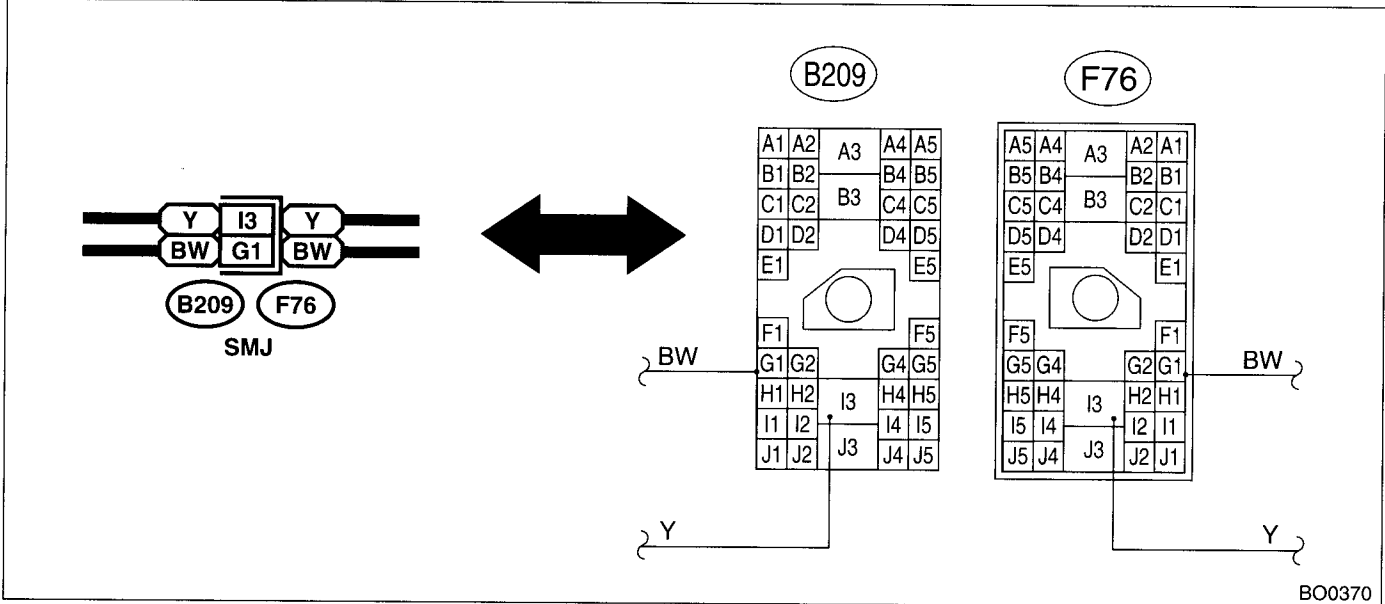

4. Power Supply Routing

A: SCHEMATIC

P-SUP-01

P-SUP-01

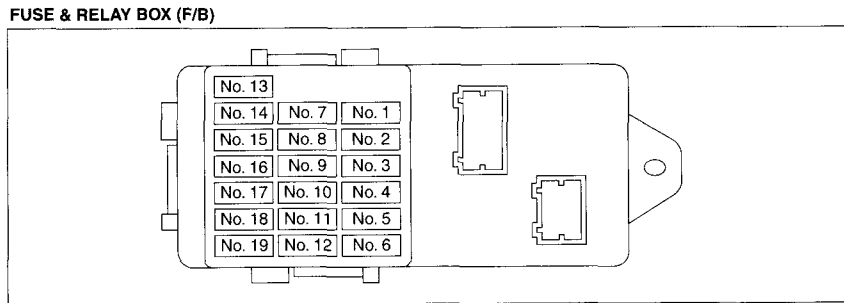
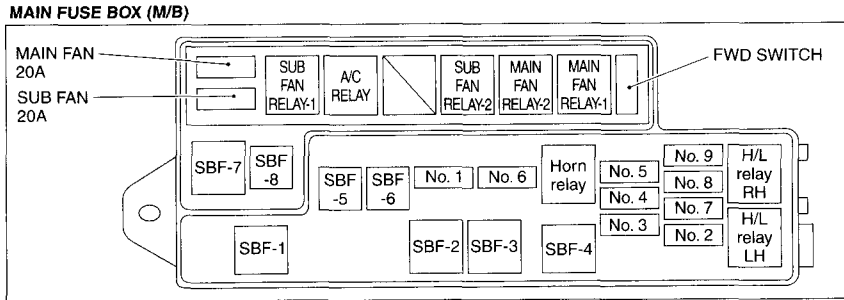

GU01-20A

POWER SUPPLY ROUTING

WIRING SYSTEM

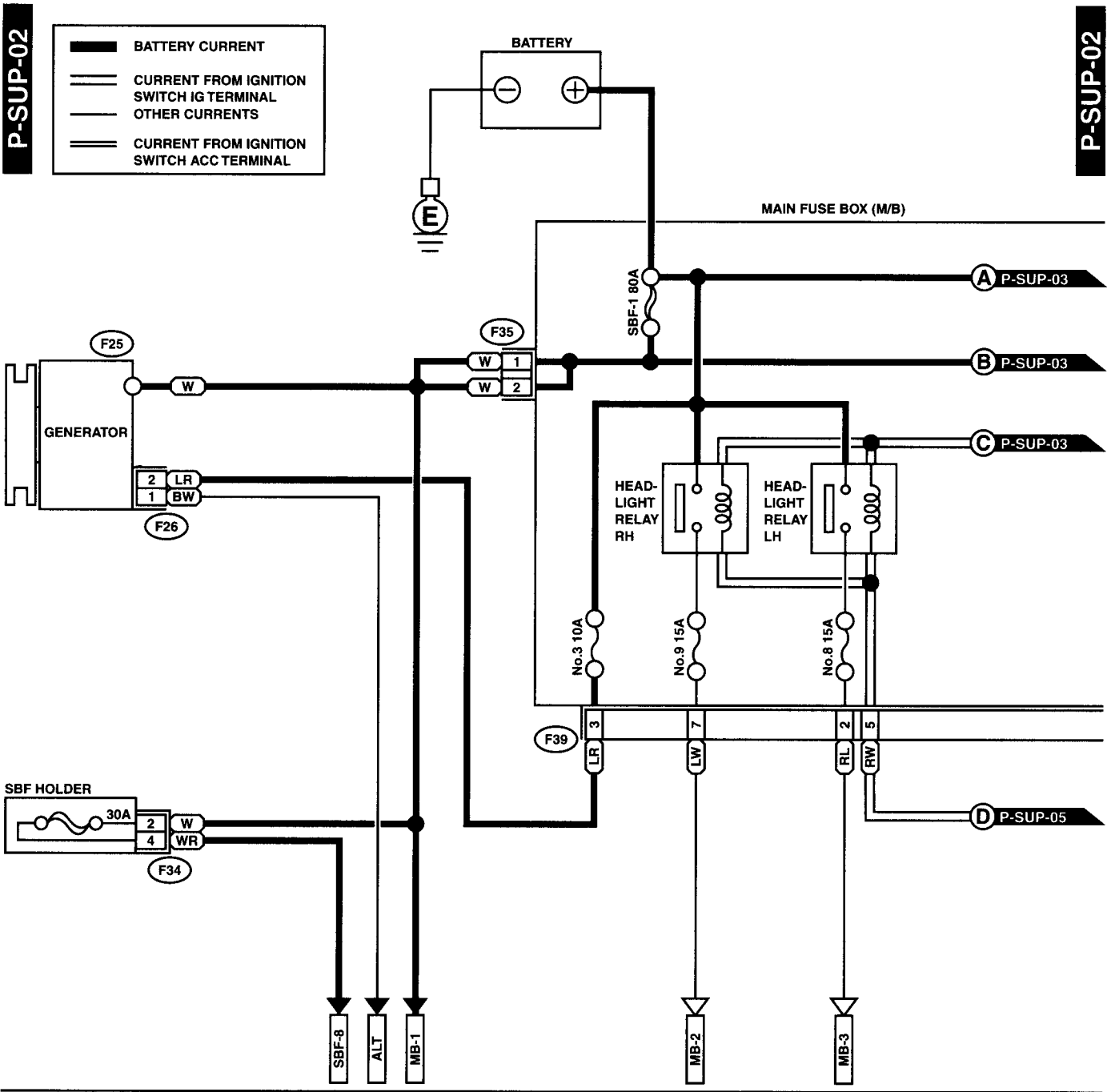

GU01-20B

POWER SUPPLY ROUTING

WIRING SYSTEM

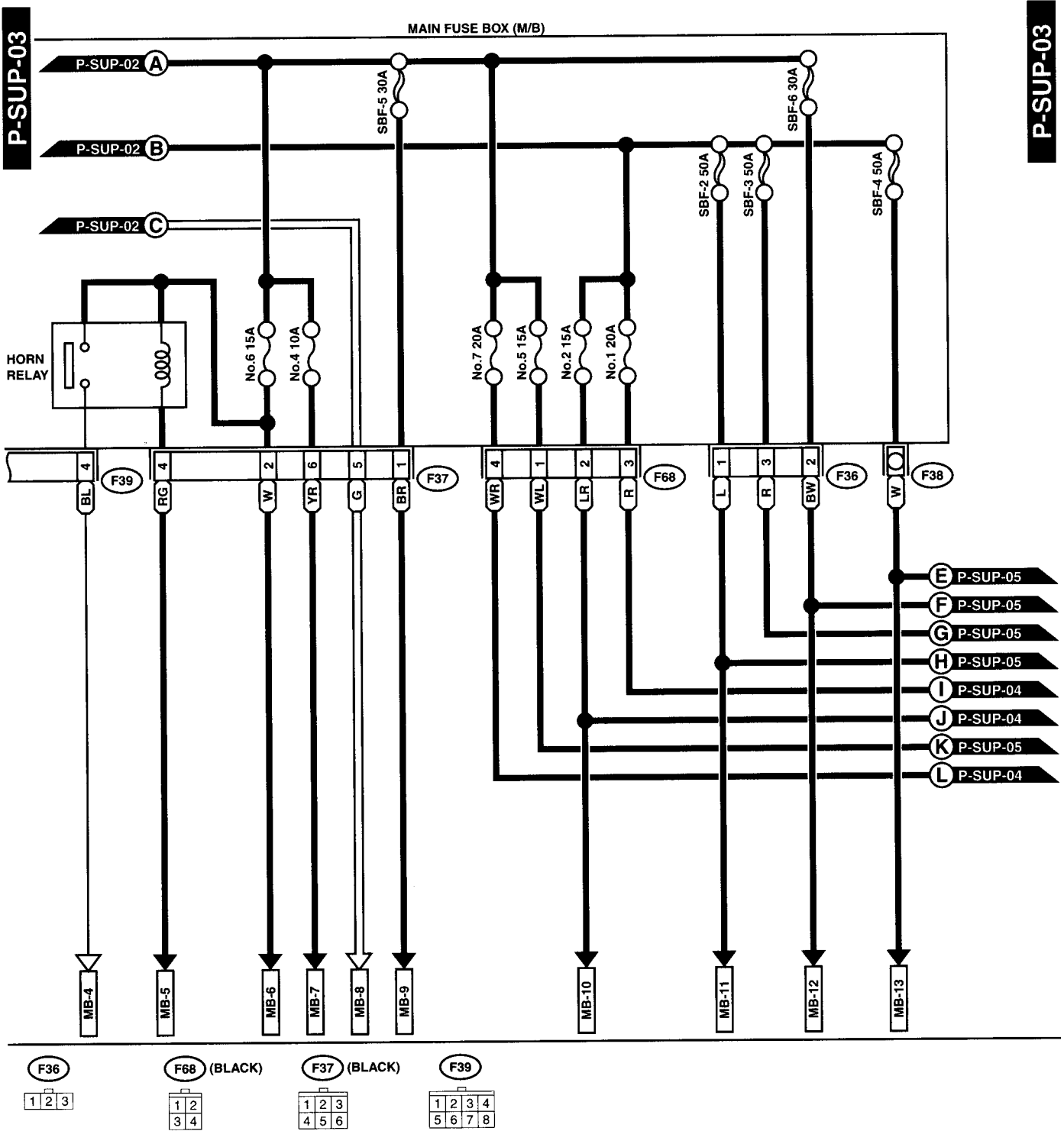

GU01-20C

POWER SUPPLY ROUTING

WIRING SYSTEM

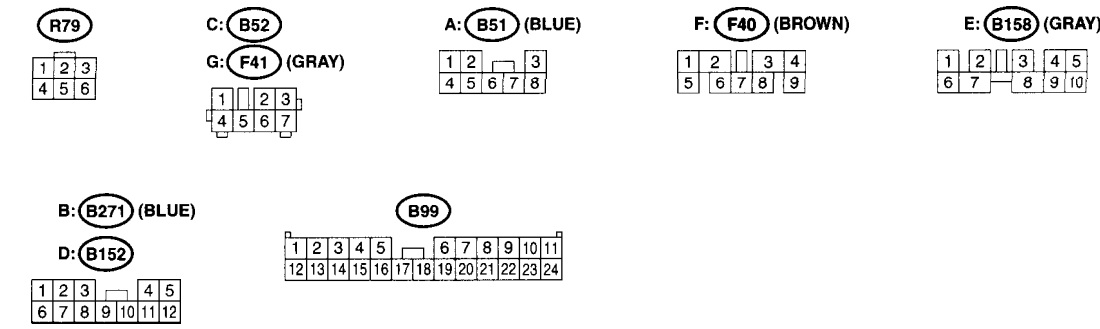
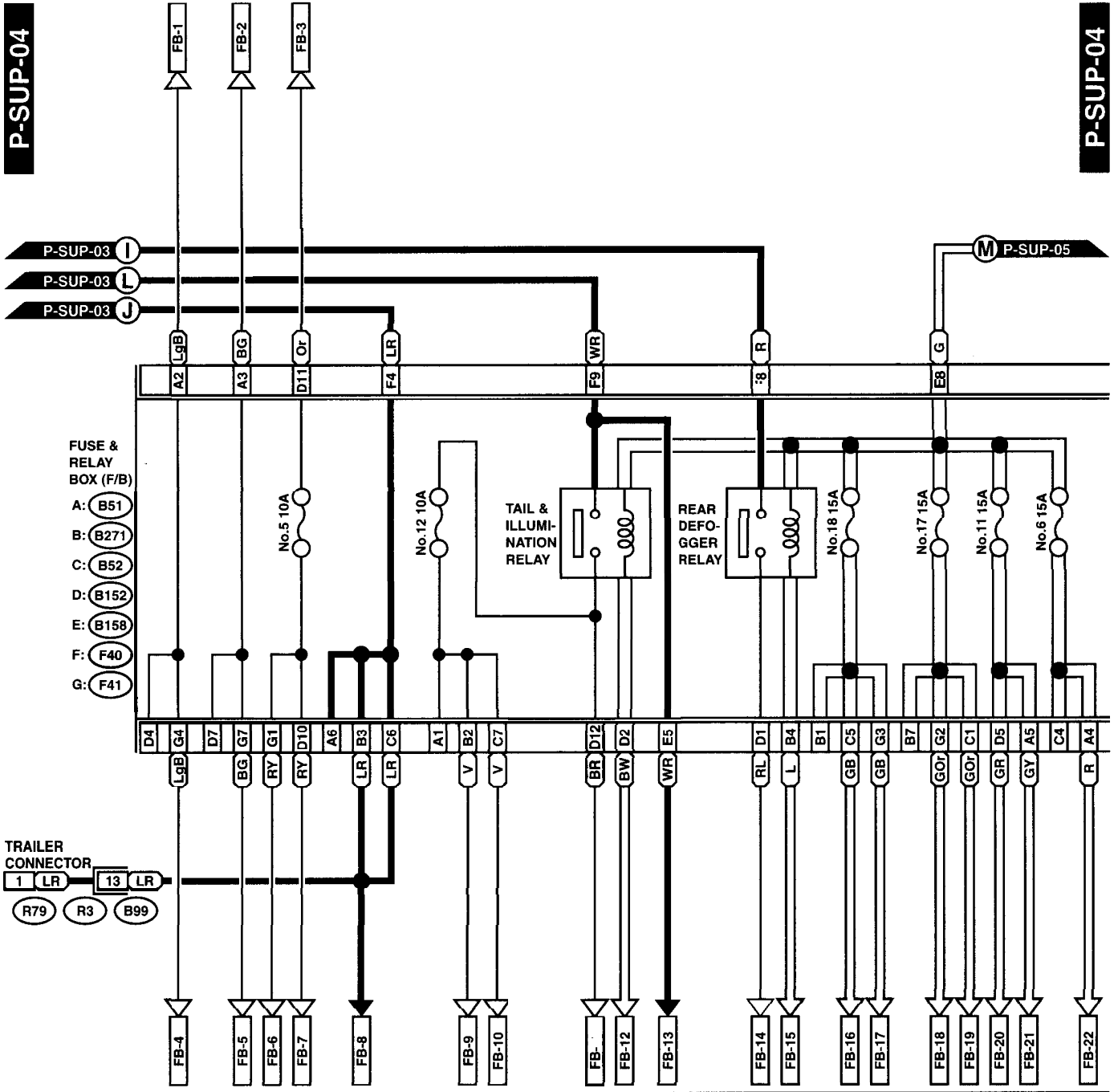

GU01-20D

POWER SUPPLY ROUTING

WIRING SYSTEM

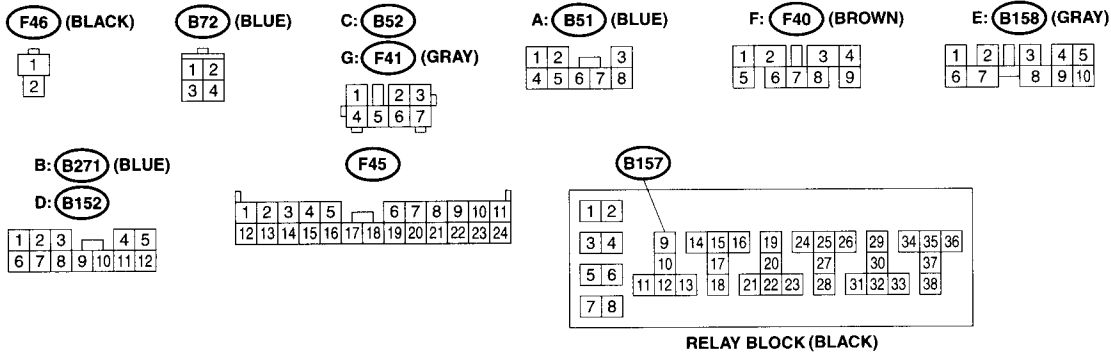
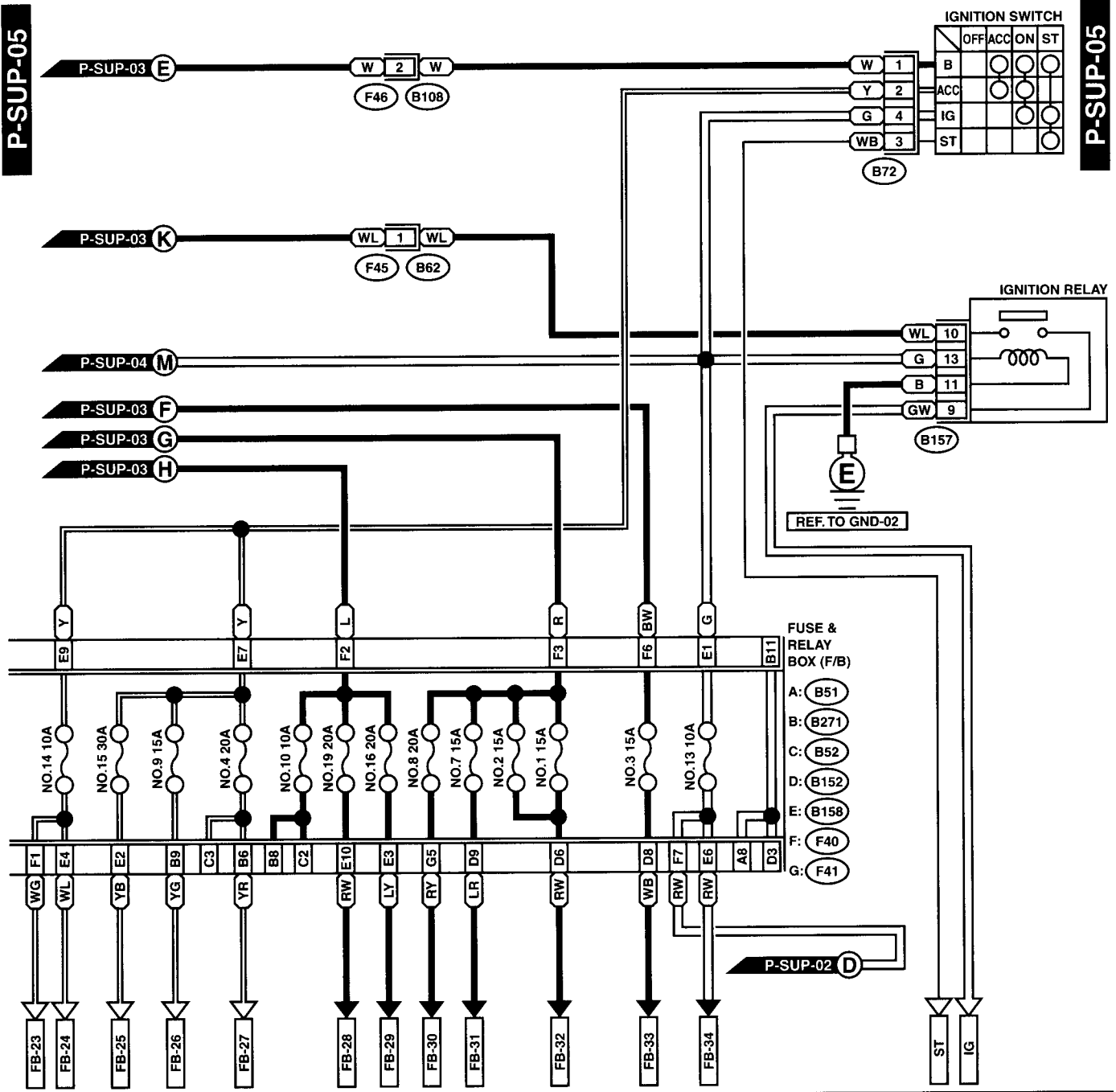

RELAY BLOCK (BLACK)

GU01-20E

POWER SUPPLY ROUTING

WIRING SYSTEM

No.	Load
MB-1	Air conditioning relay holder (Fuse)
MB-2	Combination meter Headlight RH
MB-3	Headlight LH
MB-4	Horn
MB-5	Cruise control sub switch Horn switch Keyless entry control module Security horn relay
MB-6	Hazard switch Key warning switch
MB-7	Transmission control module
MB-8	Daytime running light control module Diode (Daytime running light)
MB-9	Data link connector Engine control module Fuel pump relay Main relay
MB-11	Fuse (Rear 12V accessory)
MB-12	Power window circuit breaker
MB-13	Relay holder
SBF-8	ABS control module
IG	Hazard switch Power window relay
ST	Engine control module (AT) Interrupt relay
FB-1	Combination meter Hazard switch Rear turn signal light RH Trailer connector Turn signal switch
FB-2	Combination meter Hazard switch Rear turn signal light LH Trailer connector Turn signal switch
FB-3	Parking switch Security control module
FB-4	Front turn signal light RH
FB-5	Front turn signal light LH
FB-6	Front clearance light LH Front clearance light RH Side marker light LH Side marker light RH
FB-7	License plate light Tail light LH Tail light RH Trailer connector

No.	Load
FB-8	Clock Combination meter Integrated module Keyless entry control module Luggage room light (Wagon) Radio Room light Security control module Security horn relay Spot light Trunk room light (Sedan)
FB-9 FB-10	Clock Combination meter Illumination light Integrated module
FB-11	Parking switch
FB-12	Engine control module Lighting switch
FB-13	Parking switch Security control module
FB-14	Mirror heater relay Rear defogger Rear defogger switch
FB-15	Integrated module
FB-16	ABS relay Back-up light switch (MT) Check connector Cruise control main switch Cruise control module Daytime running light control module Daytime running light relay High-beam relay (Daytime running light) Inhibitor switch (AT) Keyless entry control module Vehicle speed sensor (MT)
FB-17	Main fan relay (Non-turbo engine model) Main fan relay-1 (Turbo engine model) Main fan relay-2 (Turbo engine model)
FB-18	Air conditioning relay Sub fan relay (Non-turbo engine model) Sub fan relay-1 (Turbo engine model) Sub fan relay-2 (Turbo engine model) Thermal protector
FB-19	Air conditioning switch Blower fan motor relay
FB-20	Engine control module Fuel pump relay Ignition coil No. 1 (Turbo engine model) Ignition coil No. 2 (Turbo engine model) Ignition coil No. 3 (Turbo engine model) Ignition coil No. 4 (Turbo engine model) Integrated module Transmission control module
FB-21	Airbag control module
FB-22	Airbag control module
FB-23	Rear washer motor
FB-24	Rear wiper intermittent module Rear wiper motor

POWER SUPPLY ROUTING

WIRING SYSTEM

No.	Load
FB-25	Combination switch Front washer motor Front wiper motor
FB-26	Clock Radio
FB-27	Compass mirror Front accessory power supply socket Integrated module Rear 12V accessory relay Remote controlled rearview mirror switch
FB-28	Mirror heater relay
FB-29	Stop light switch
FB-30	ABS control module
FB-31	Front fog light relay
FB-32	Blower fan motor relay
FB-33	Integrated module
FB-34	Combination meter

GROUND DISTRIBUTION

WIRING SYSTEM

5. Ground Distribution

A: SCHEMATIC

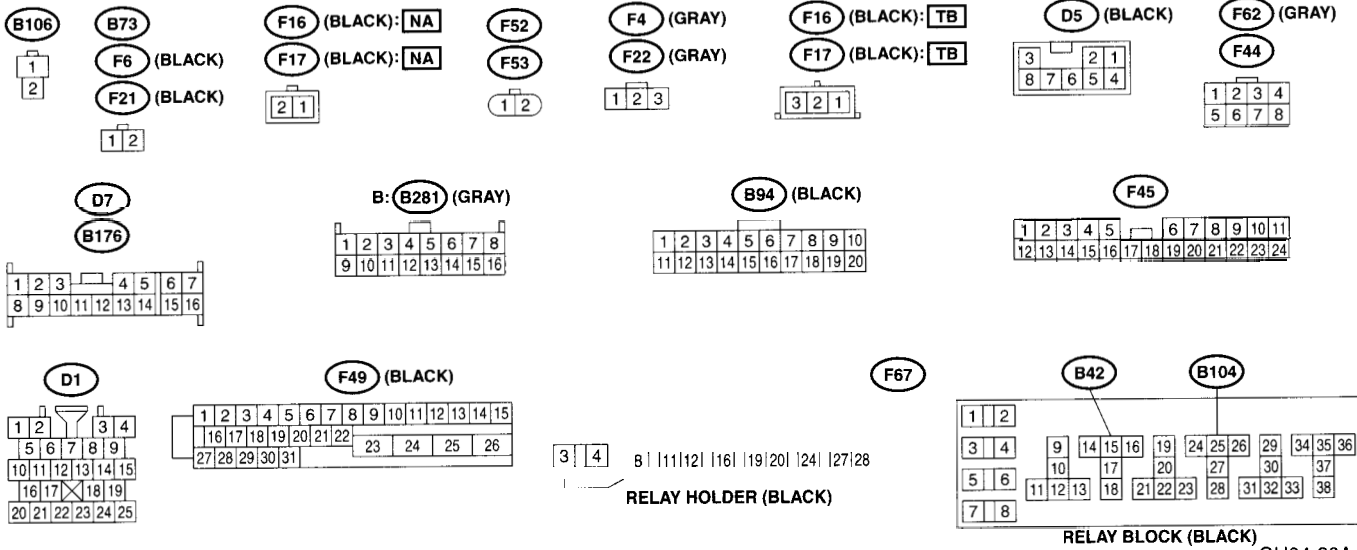
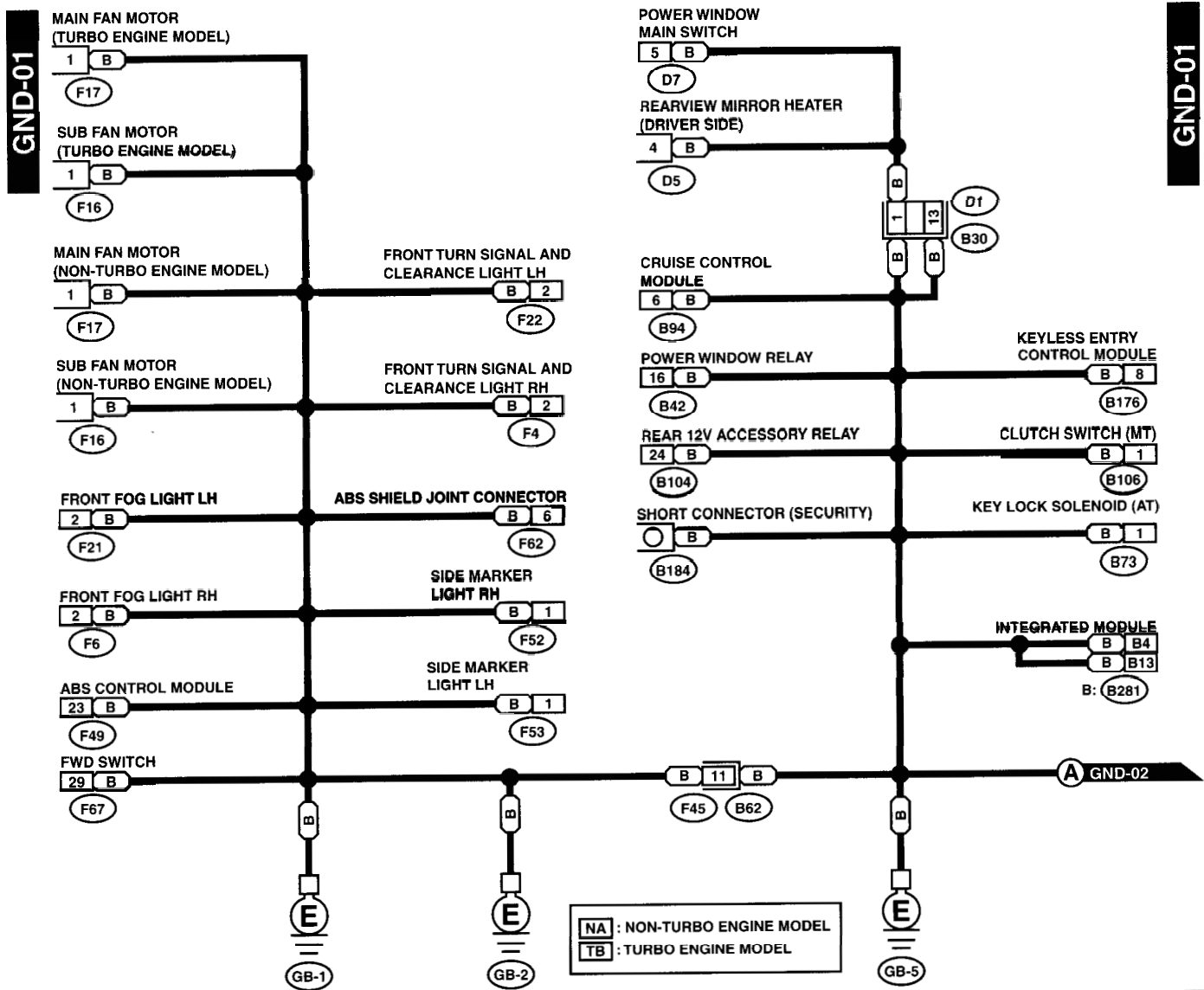

GROUND DISTRIBUTION

WIRING SYSTEM

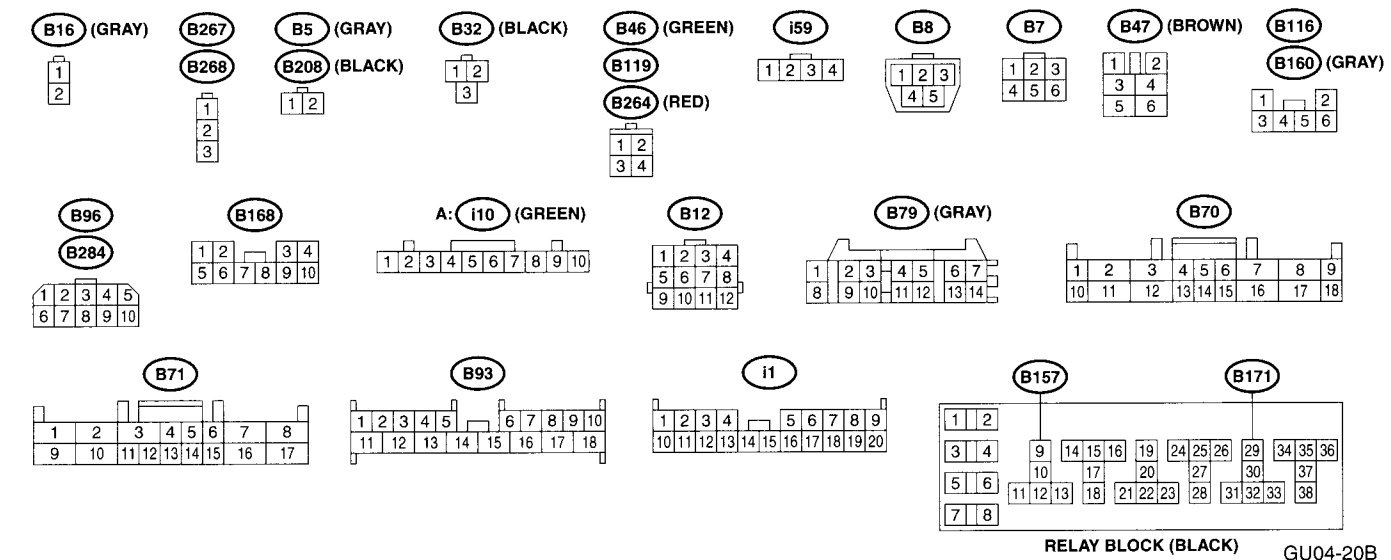
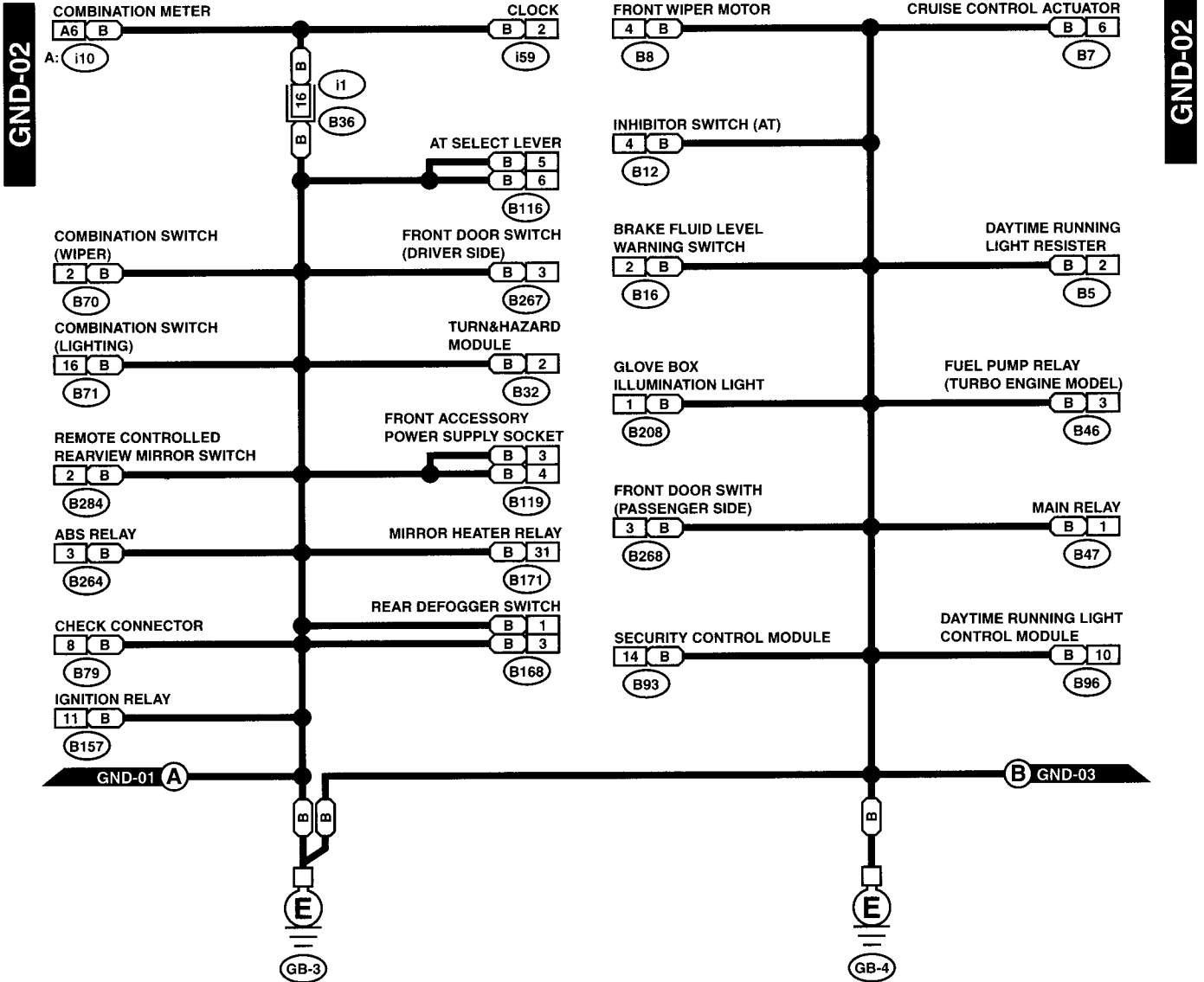

GROUND DISTRIBUTION

WIRING SYSTEM

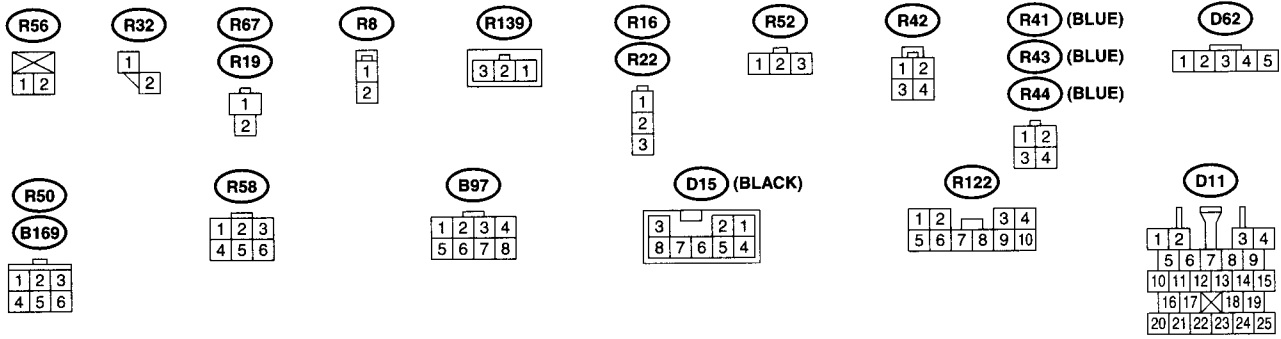
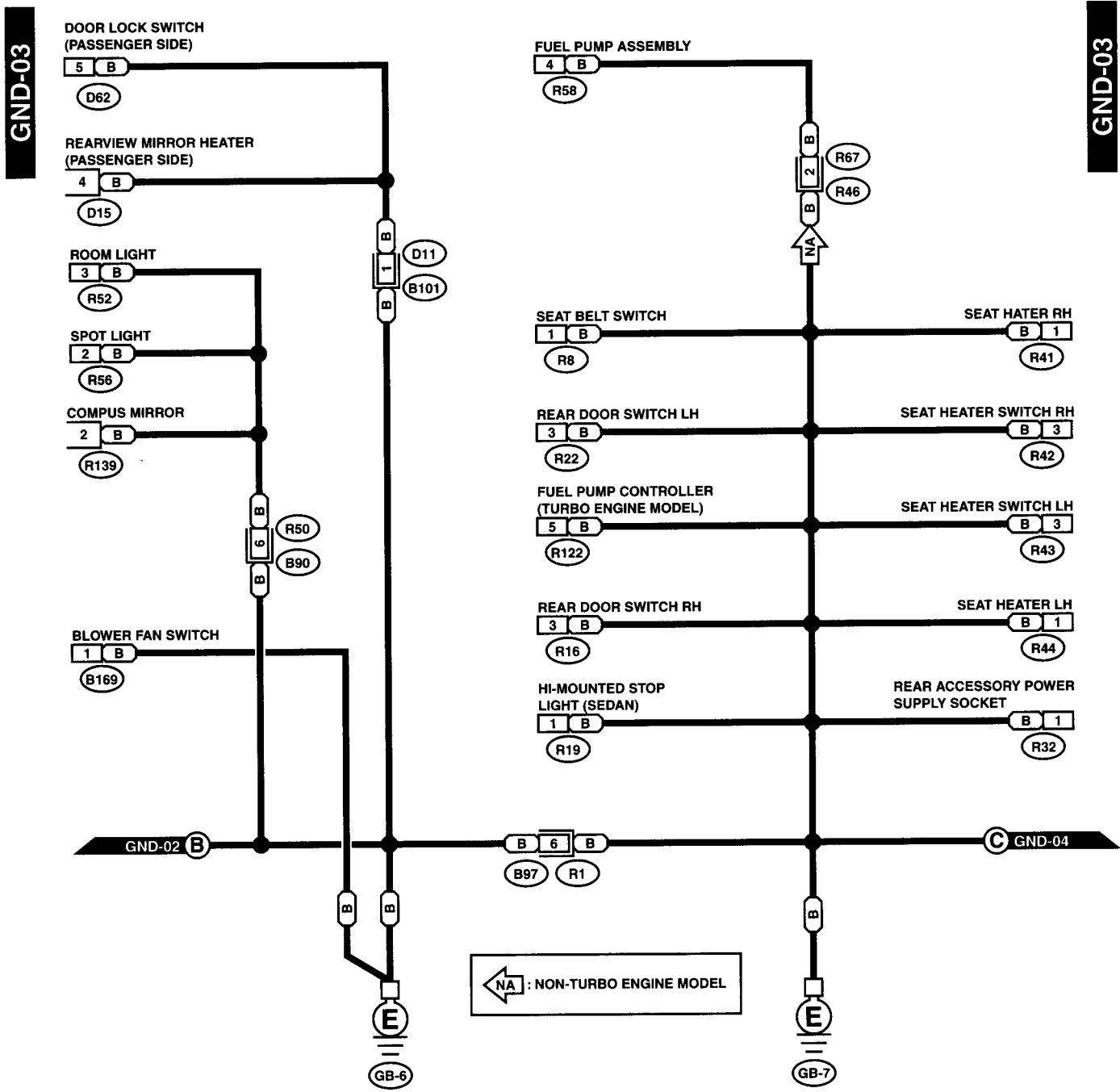

GU04-20C

GROUND DISTRIBUTION

WIRING SYSTEM

GND-04

GND-04

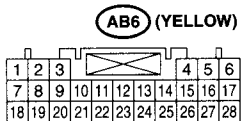
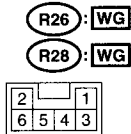
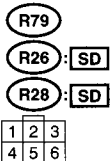
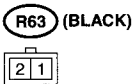
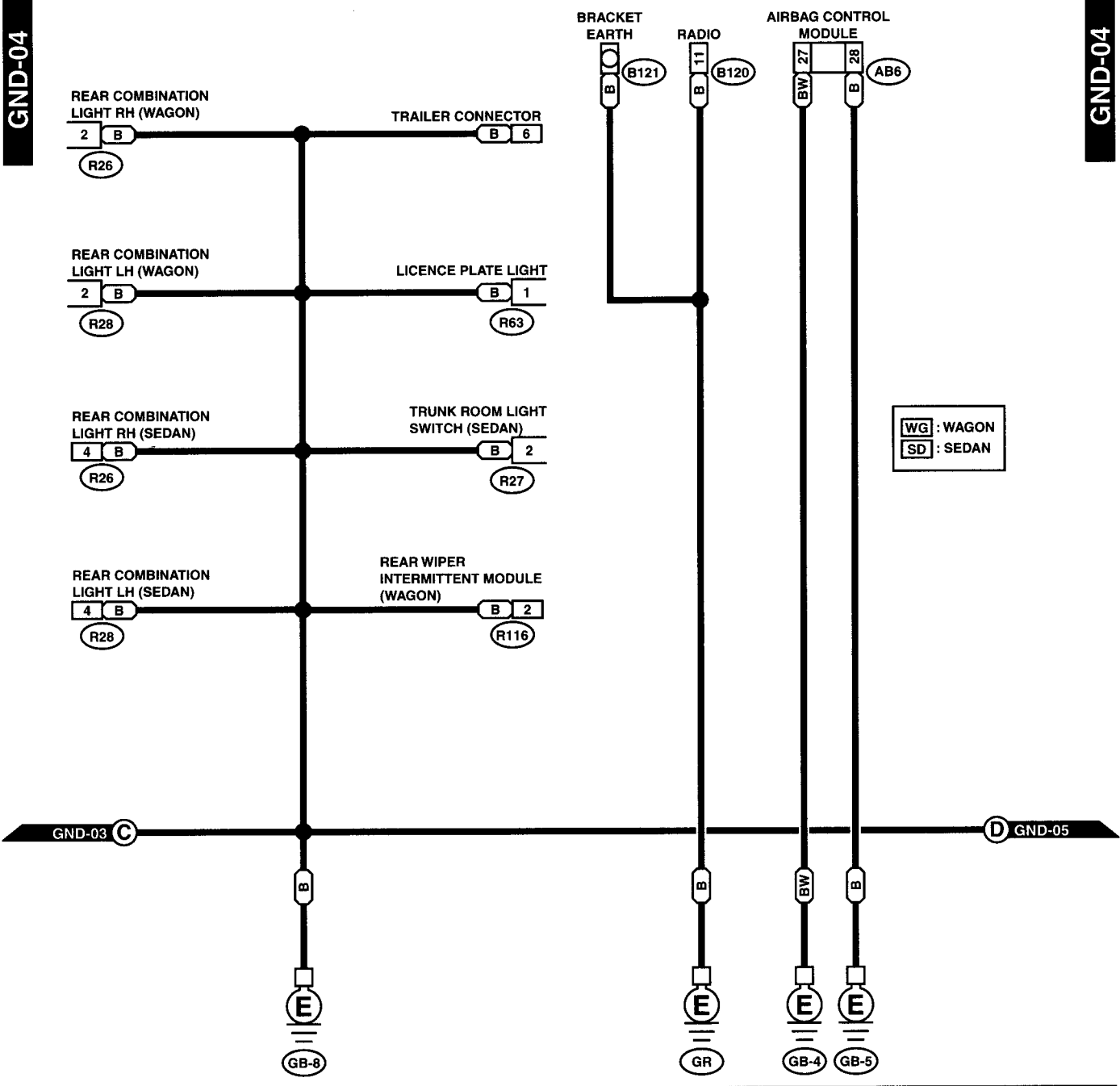

GU04-20D

GROUND DISTRIBUTION

WIRING SYSTEM

GND-05

GND-05

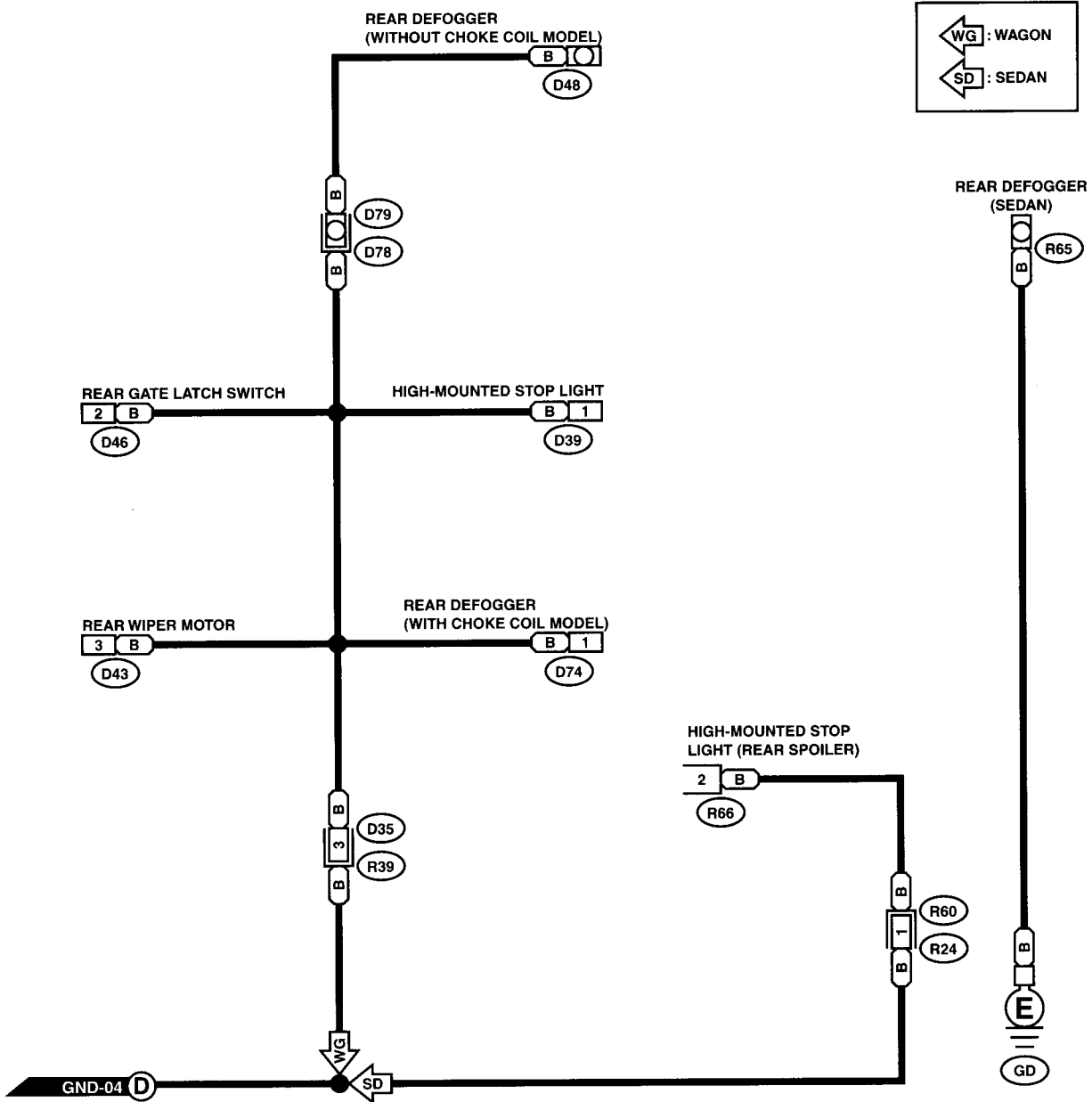

GU04-20E

GND-06

GND-06

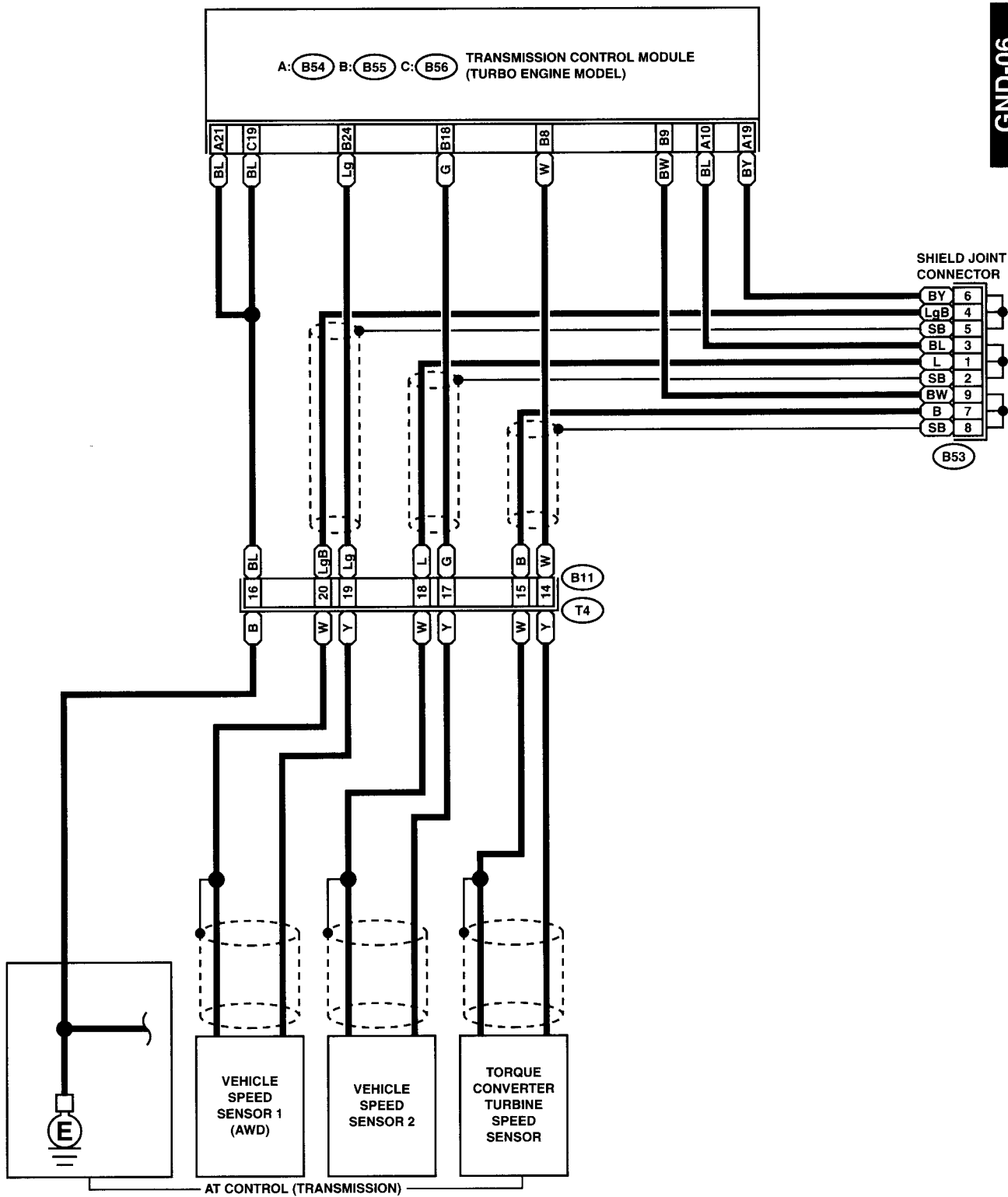

B53 (BLACK)

1	2	3	4	5	6	7	8	9	10	11	12
---	---	---	---	---	---	---	---	---	----	----	----

B11 (BLACK)

1	2	3	4
5	6	7	8
9	10	11	12
13	14	15	16
17	18	19	20

A: B54

1	2	3	4	5	6	7	8	9
10	11	12	13	14	15	16	17	18
19	20	21		22	23	24		

B: B55 (GRAY)

1	2	3	4	5	6	7	8	9
10	11	12	13	14	15	16	17	18
19	20	21		22	23	24		

C: B56 (GREEN)

1	2	3	4	5	6	7	8	9
10	11	12	13	14	15	16	17	18
19	20	21		22	23	24		

GU04-20F

GROUND DISTRIBUTION

WIRING SYSTEM

GND-07

GND-07

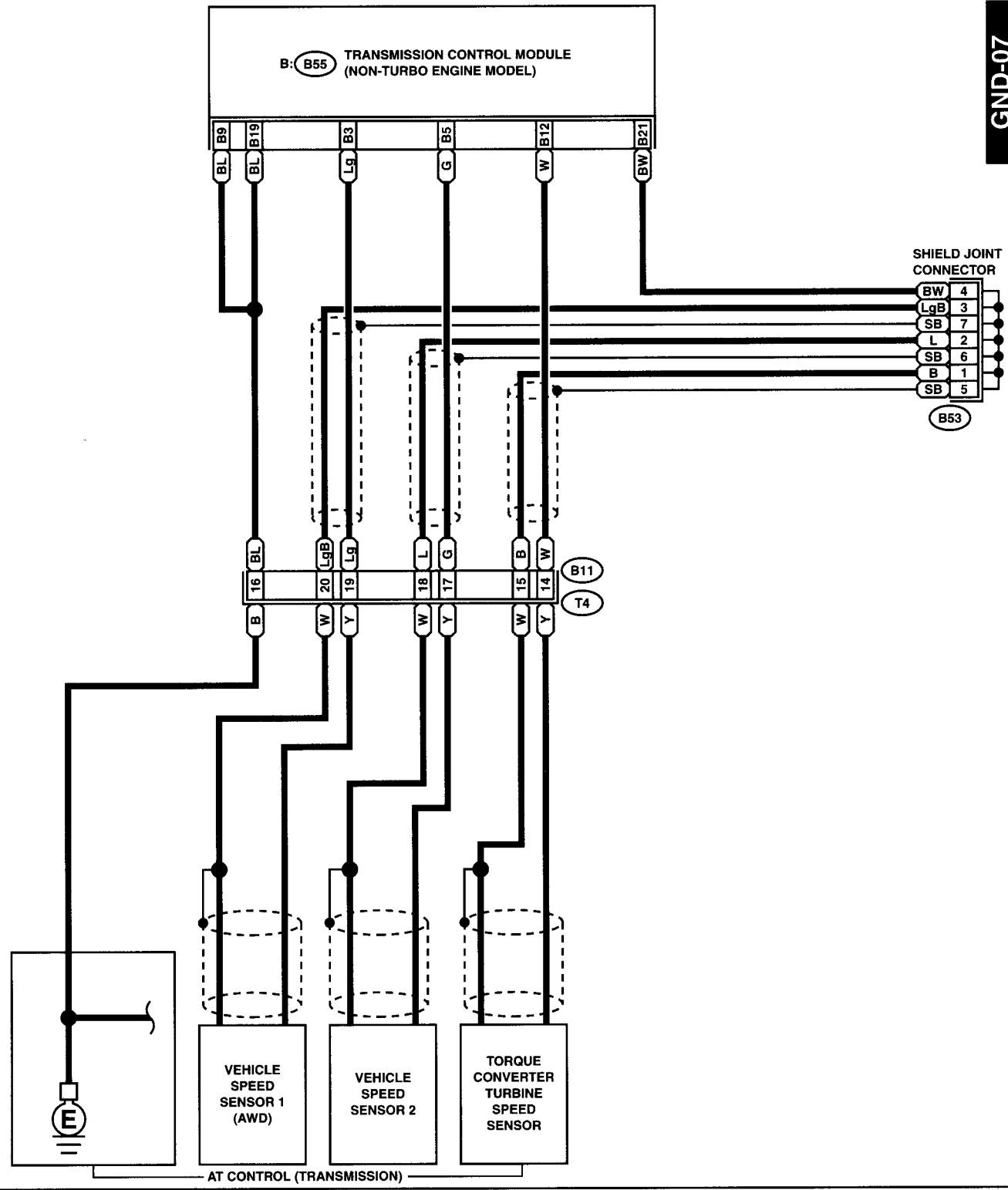

B53

1	2	3	4
5	6	7	8

B11 (BLACK)

1	2	3	4
5	6	7	8
9	10	11	12
13	14	15	16
17	18	19	20

B: B55 (GRAY)

1	2	3	4	5	6	7	8	9
10	11	12	13	14	15	16	17	18
19	20	21		22	23	24		

GU04-20G

GROUND DISTRIBUTION

WIRING SYSTEM

GND-08

GND-08

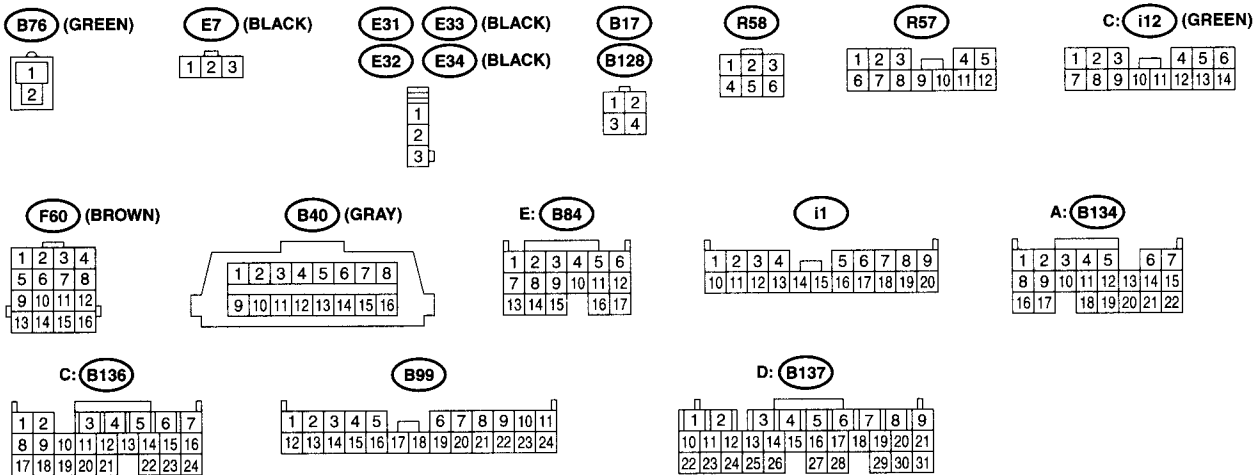
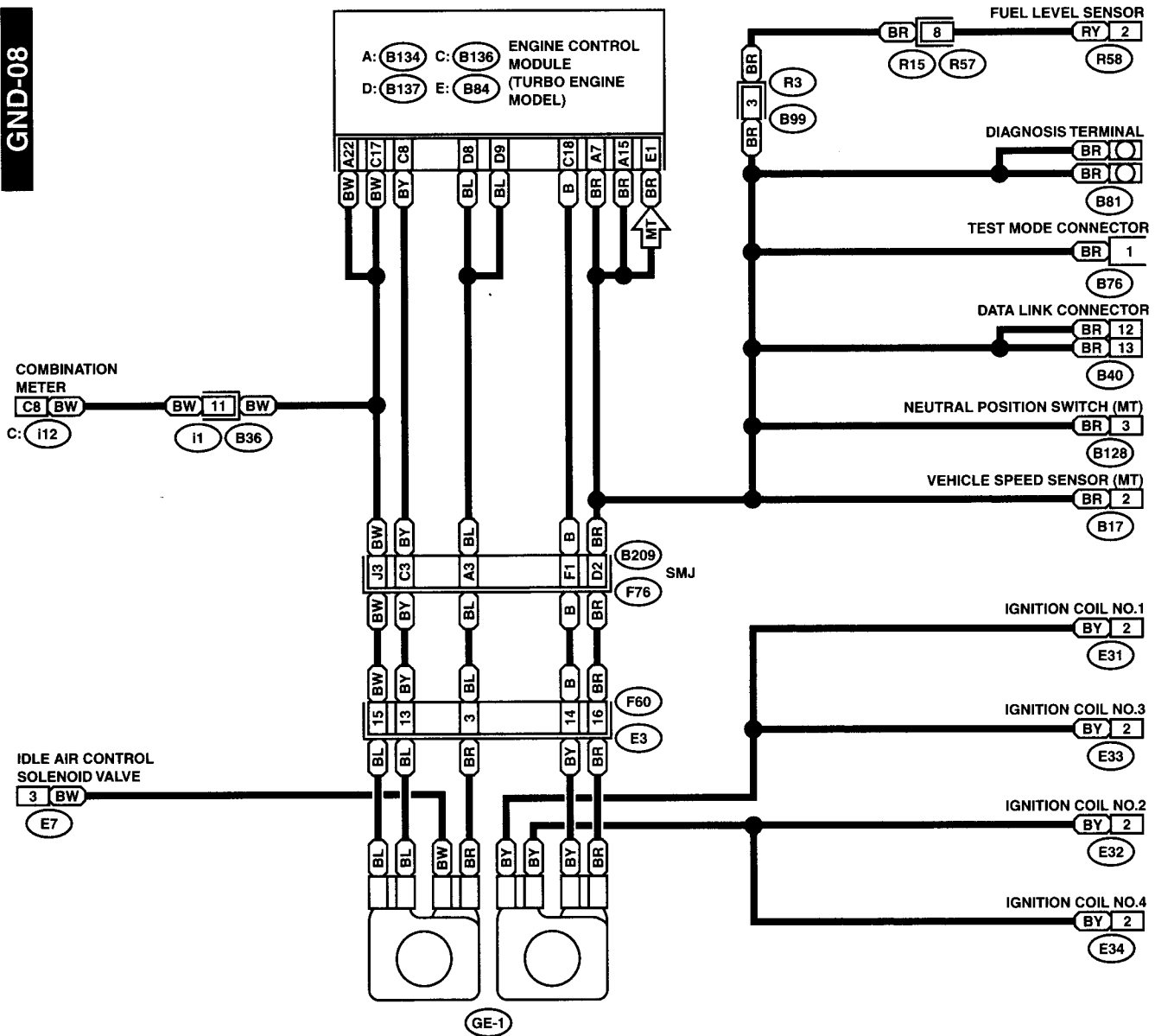

GU04-20H

GROUND DISTRIBUTION

WIRING SYSTEM

GND-09

GND-09

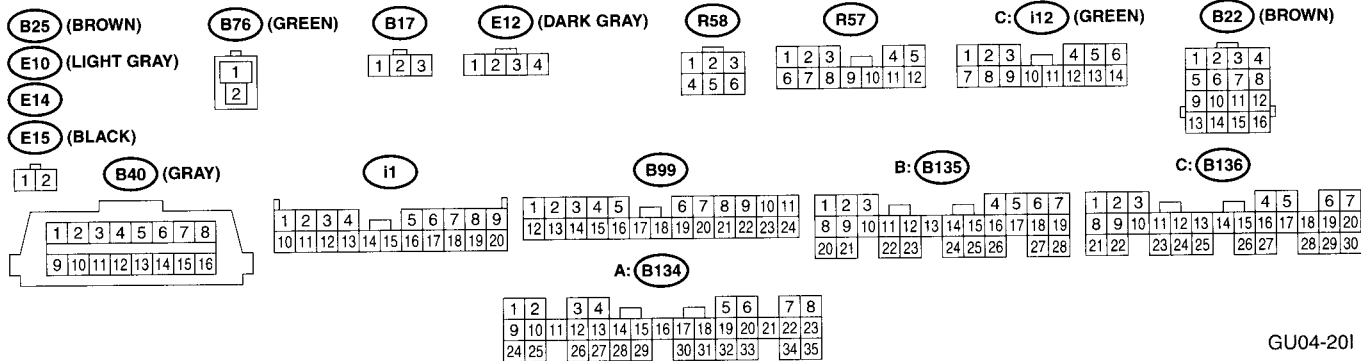
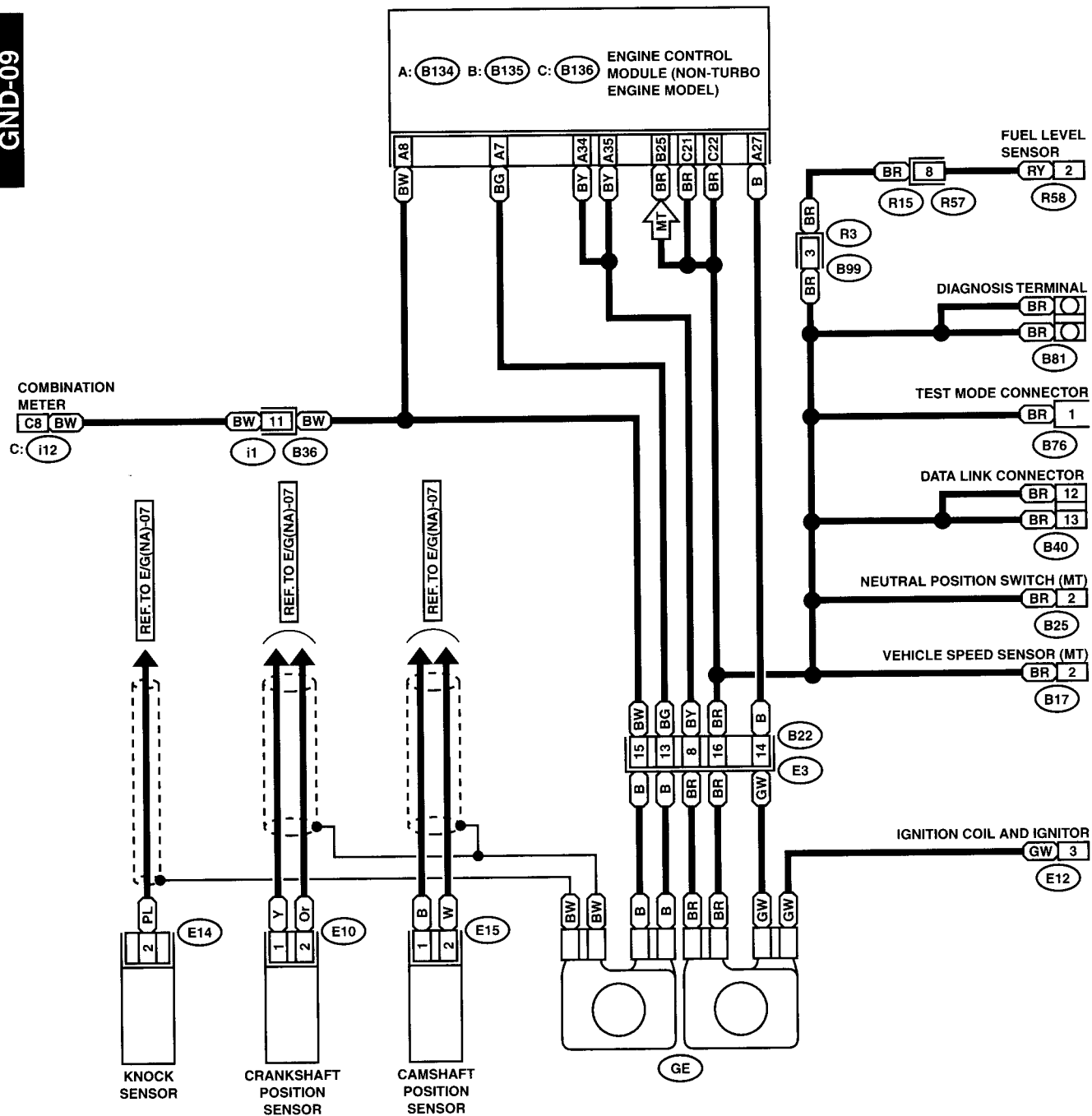

GU04-201

6. Airbag System

A: SCHEMATIC

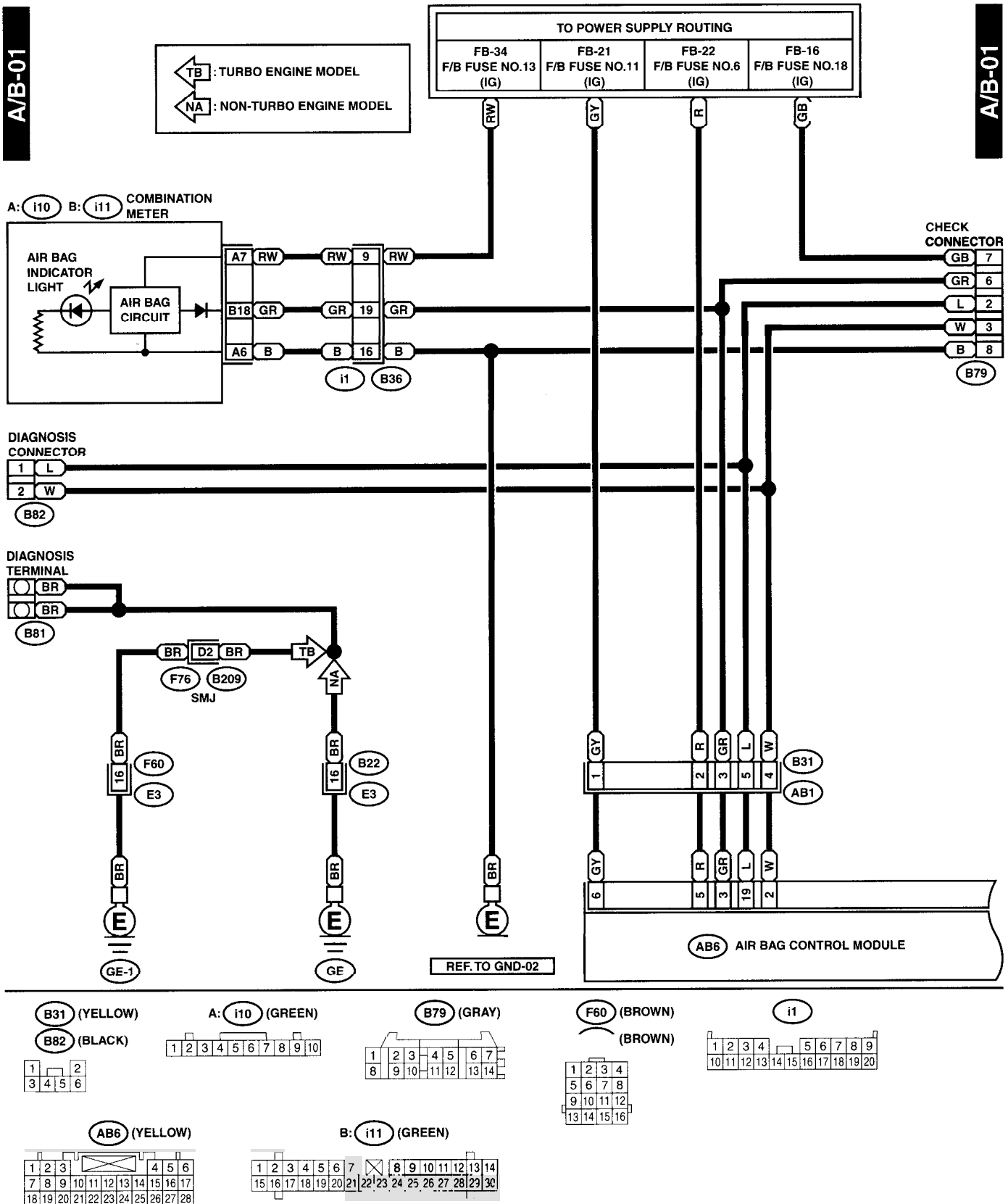

AIRBAG SYSTEM

WIRING SYSTEM

A/B-02

A/B-02

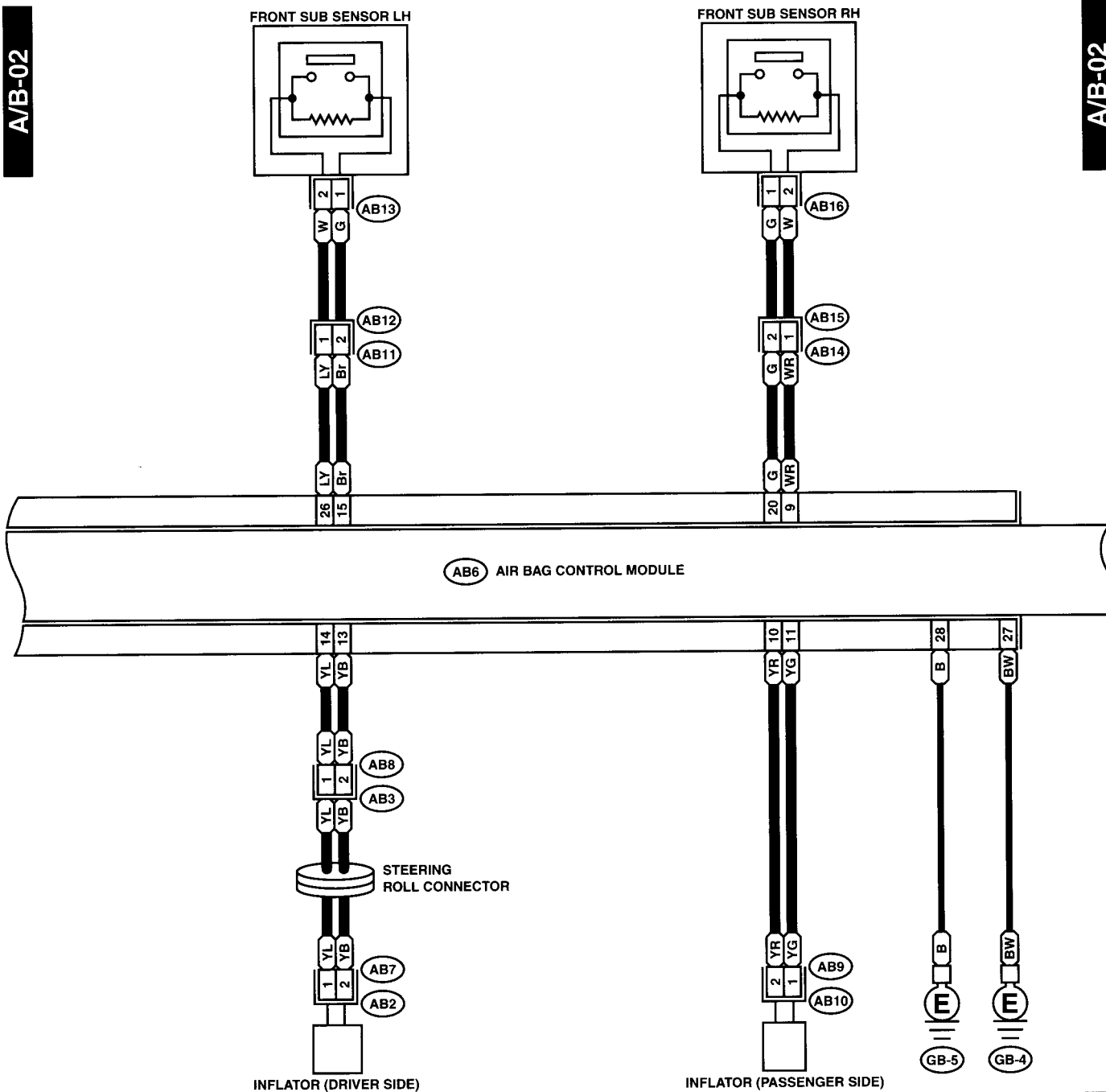

- AB7 (YELLOW)
- AB8 (YELLOW)
- AB9 (YELLOW)
- AB11 (YELLOW)
- AB14 (YELLOW)
- AB13 (YELLOW)
- AB16 (YELLOW)

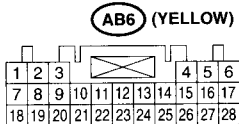

GU86-20B

AIRBAG SYSTEM

WIRING SYSTEM

A/B-03

A/B-03

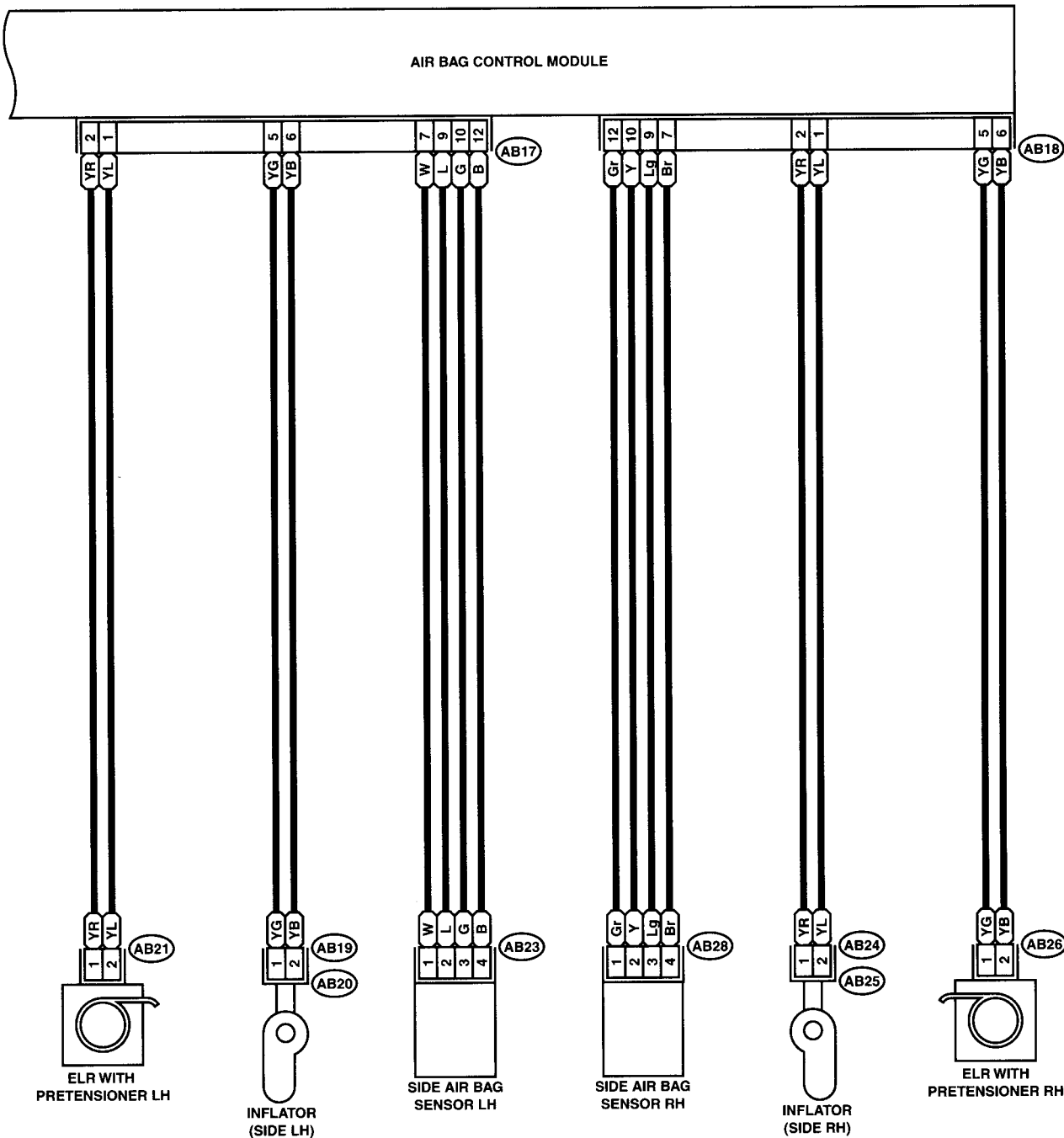

(YELLOW) AB19 (YELLOW) AB24 (YELLOW)
 (YELLOW) AB21 (YELLOW) AB26 (YELLOW)



AB23 (YELLOW) AB28 (YELLOW)

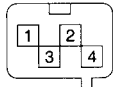

AB17 (YELLOW)

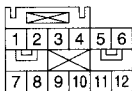

AB18 (YELLOW)

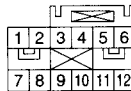

AIR CONDITIONING SYSTEM

WIRING SYSTEM

7. Air Conditioning System

A: SCHEMATIC

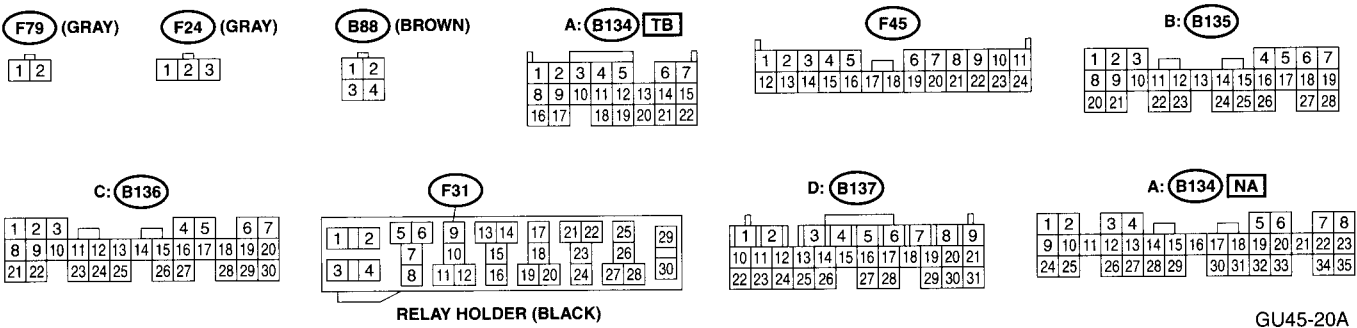
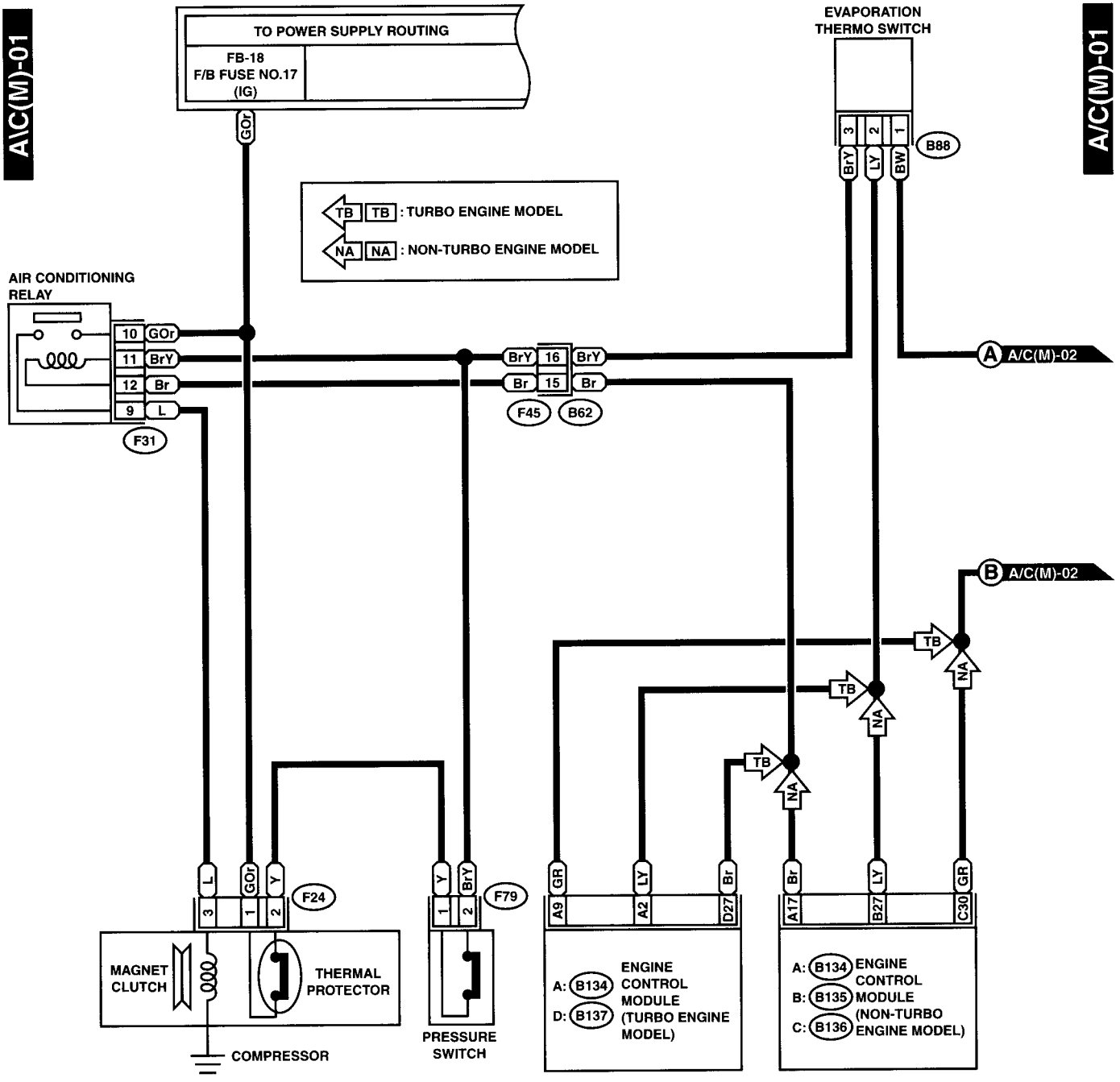

AIR CONDITIONING SYSTEM

WIRING SYSTEM

A/C(M)-02

A/C(M)-02

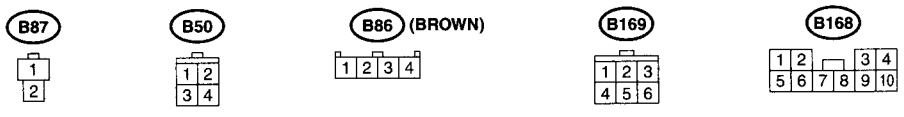
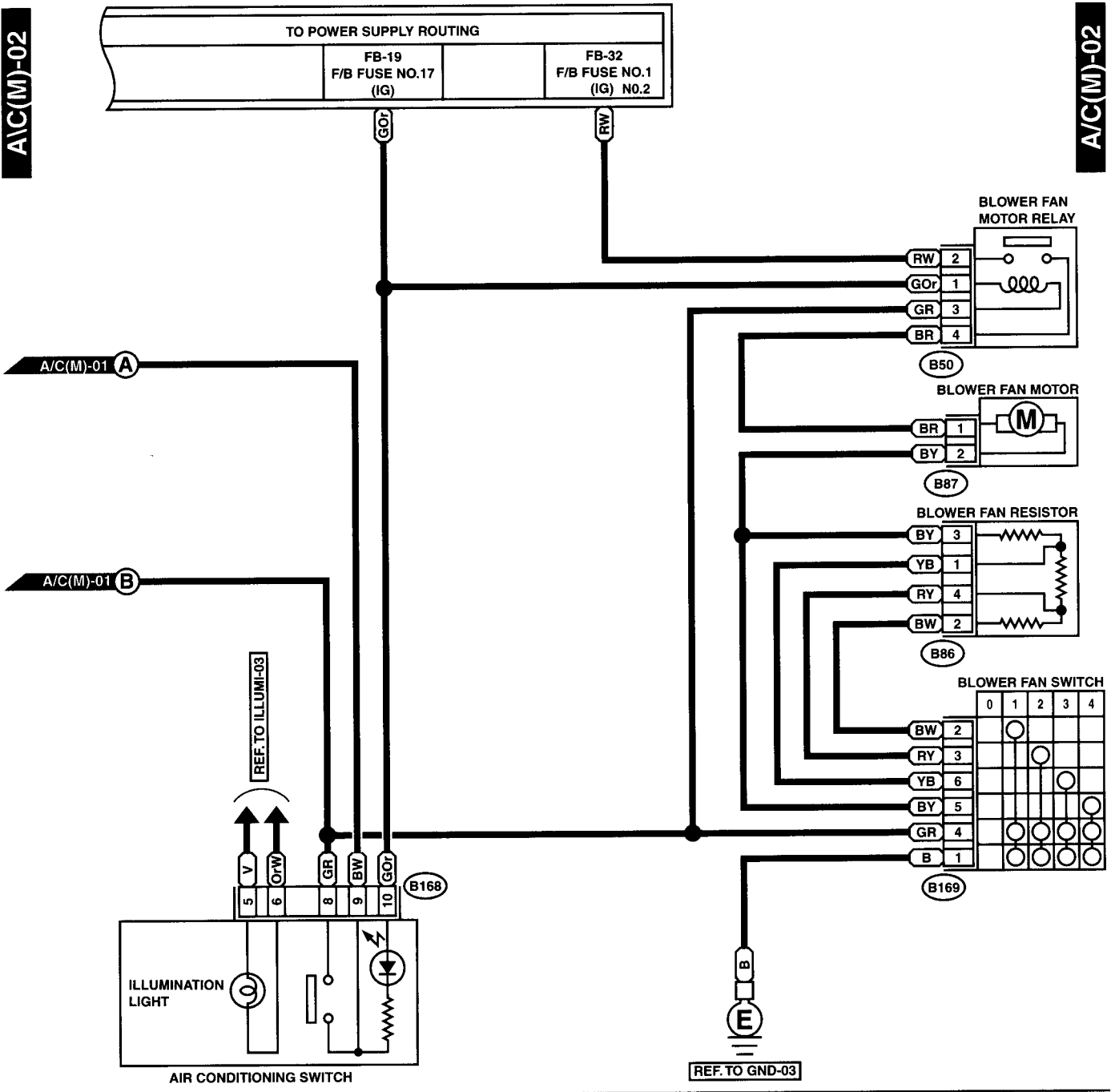

ANTI-LOCK BRAKE SYSTEM

WIRING SYSTEM

8. Anti-lock Brake System

A: SCHEMATIC

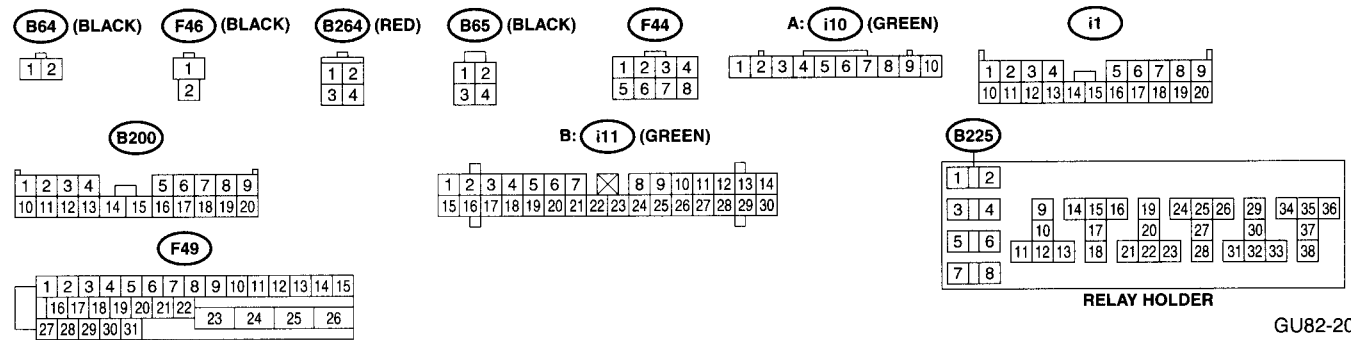
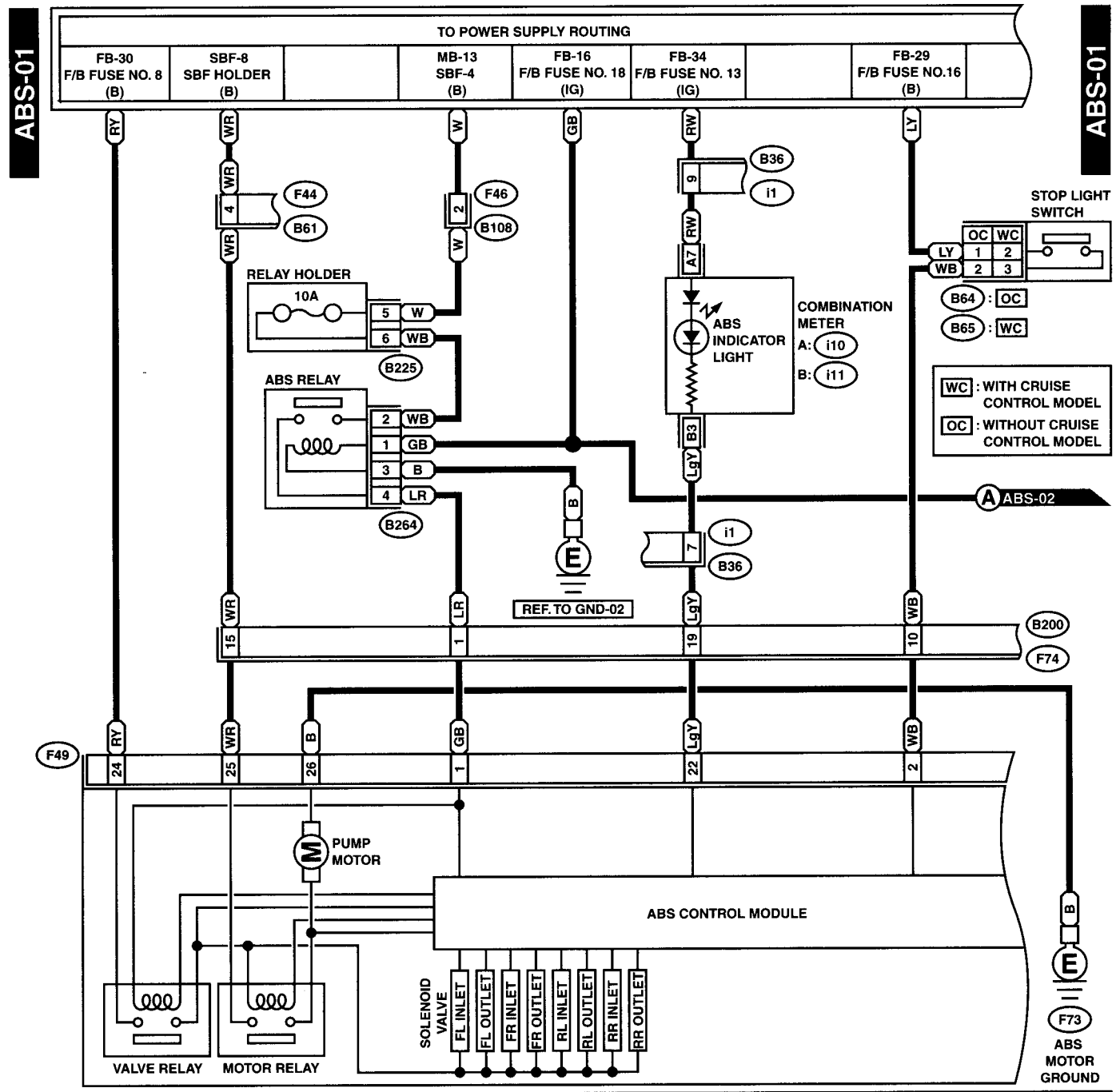

GU82-20A

ANTI-LOCK BRAKE SYSTEM

WIRING SYSTEM

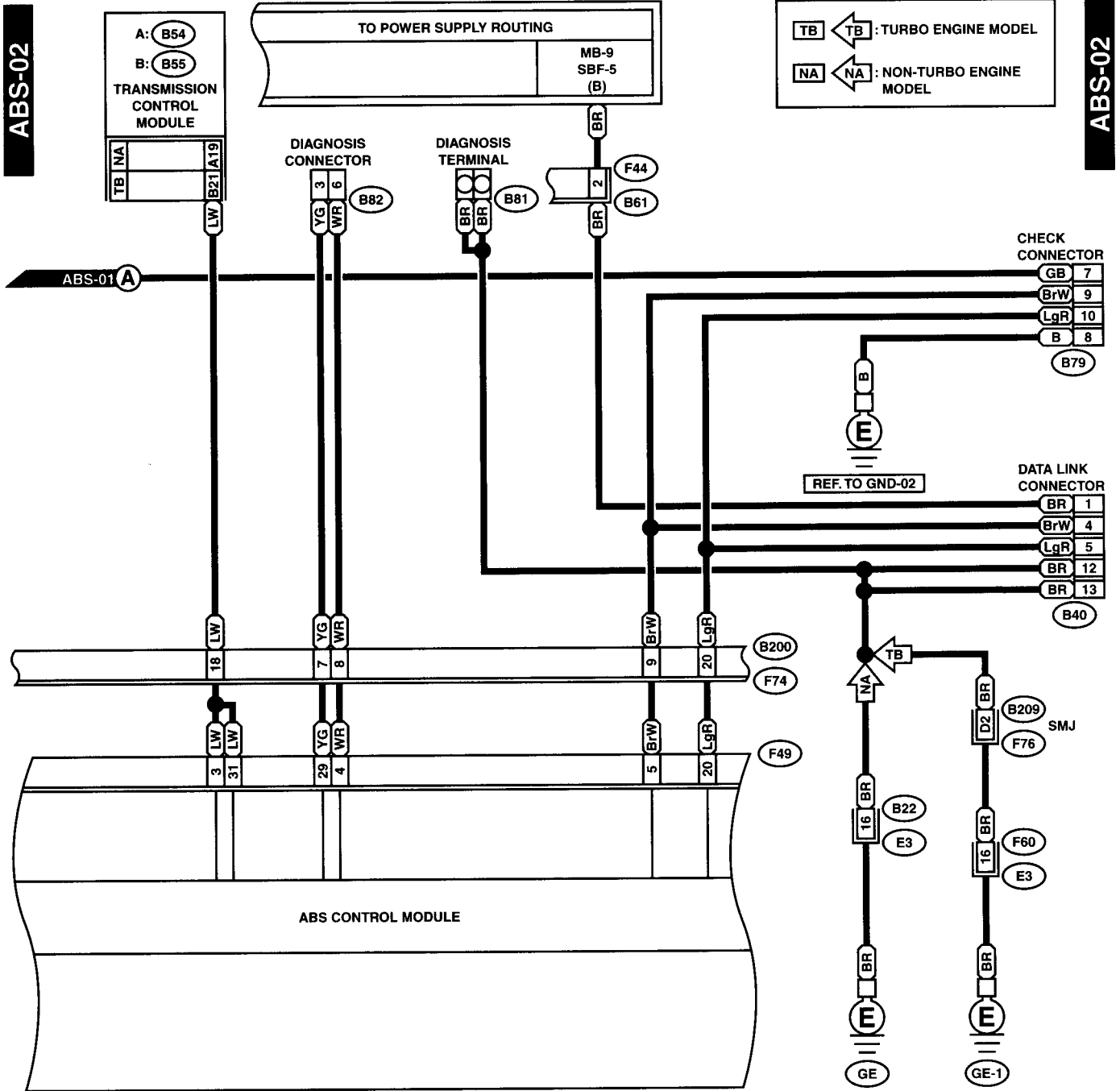

ABS-02

B82 (BLACK)



F44



B79 (GRAY)

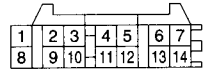

B40 (GRAY)

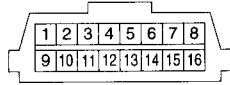

F60 (BROWN)

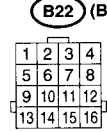

B22 (BROWN)

B200

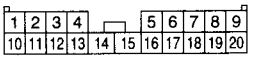

A: B54

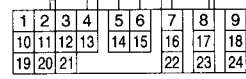

B: B55 (GRAY)

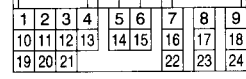

F49

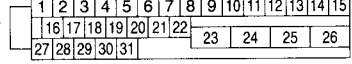

GU82-20B

ANTI-LOCK BRAKE SYSTEM

WIRING SYSTEM

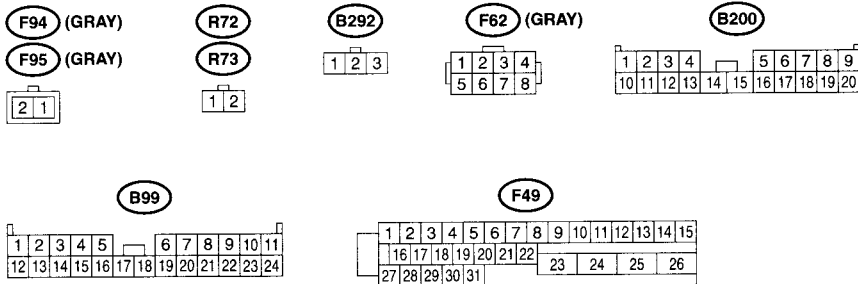
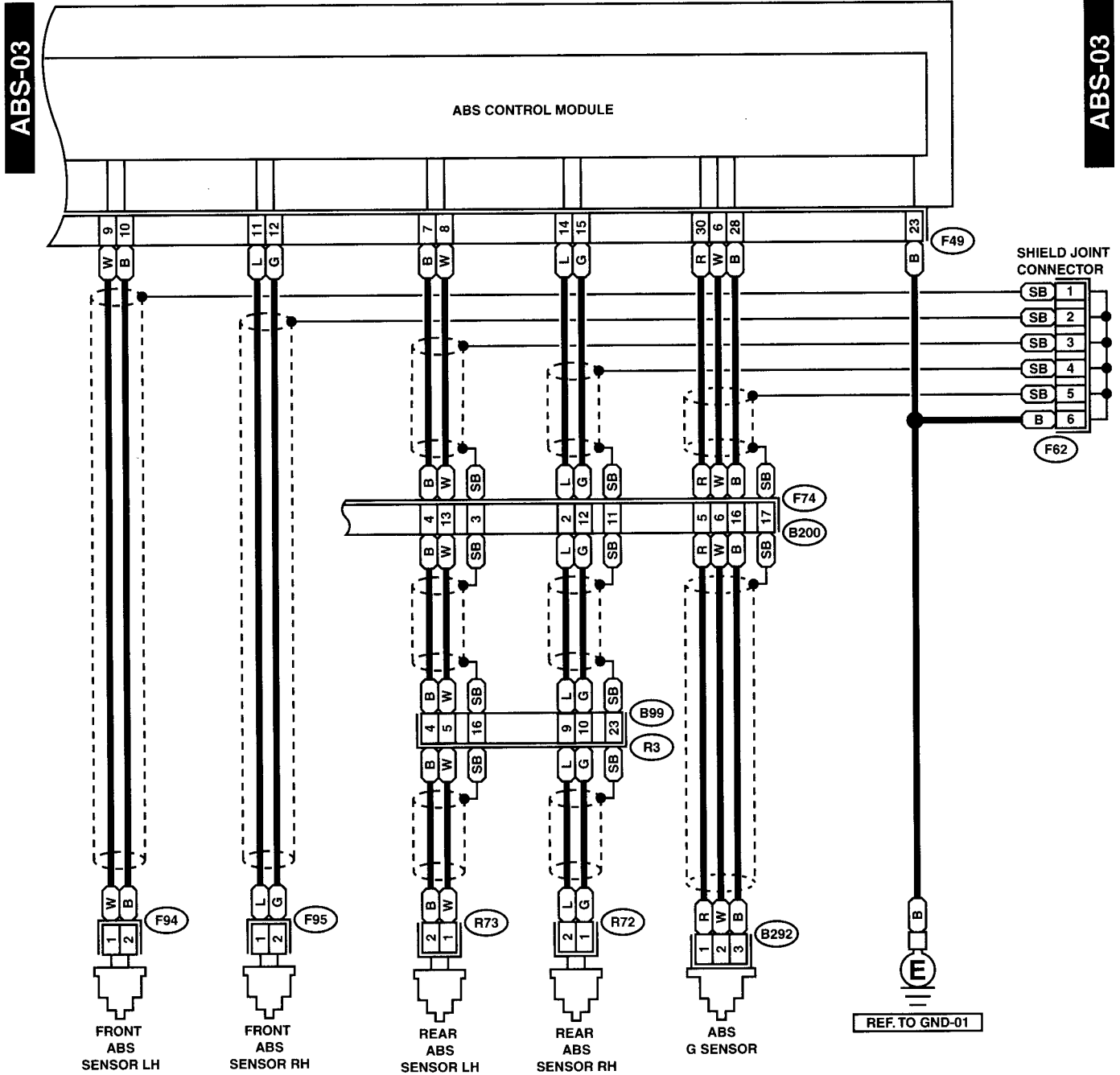

GU82-20C

9. A/T Control System

A: SCHEMATIC

A/T CONTROL SYSTEM

WIRING SYSTEM

1. TURBO ENGINE MODEL

AT(TB)-01

AT(TB)-01

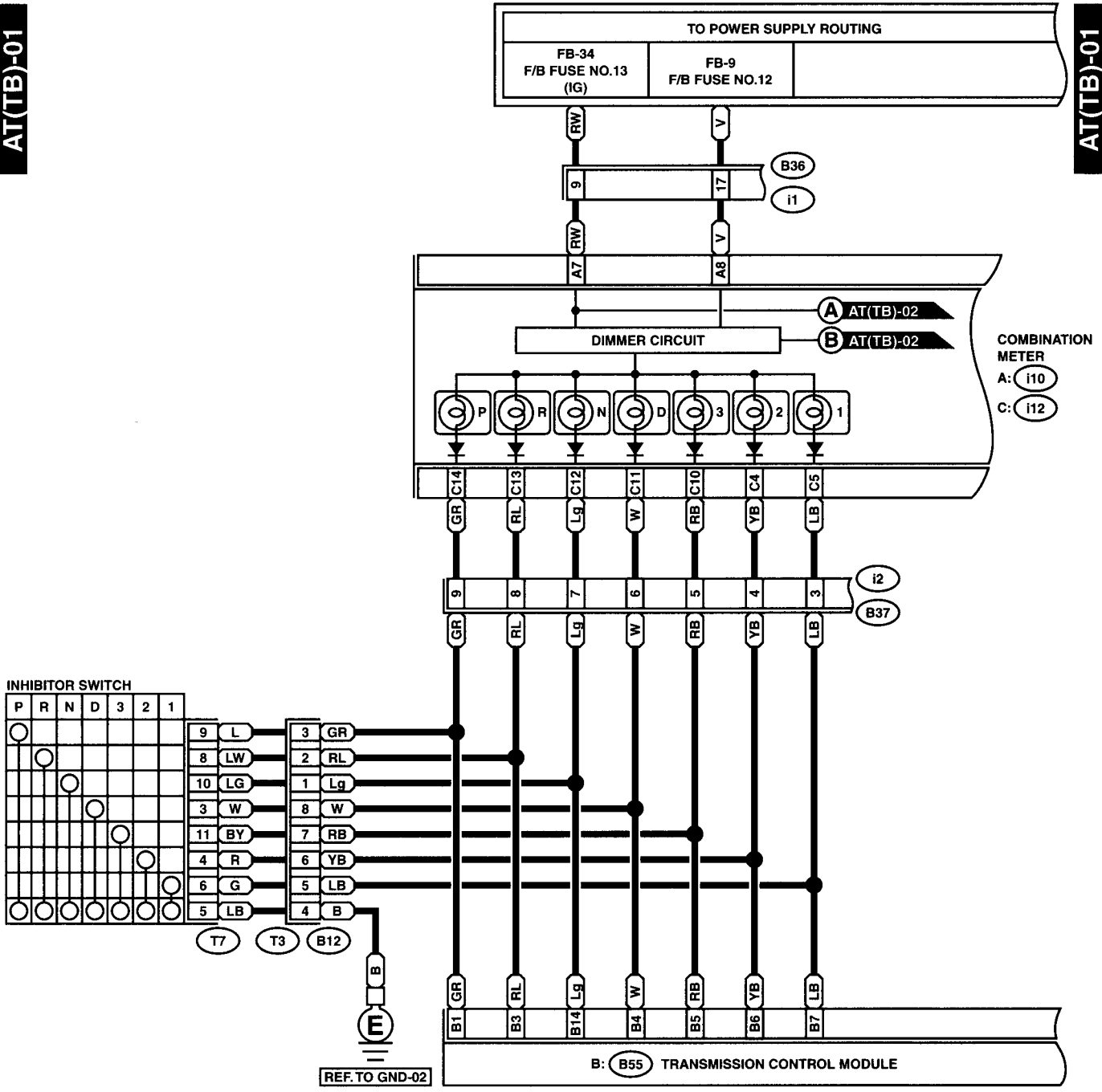

A: i10 (GREEN)

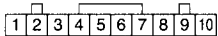

T7

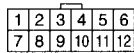

B12



C: i12 (GREEN)

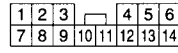

i1



i2 (BROWN)

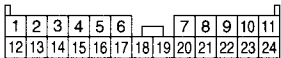

B: B55 (GRAY)

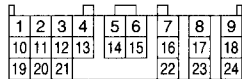

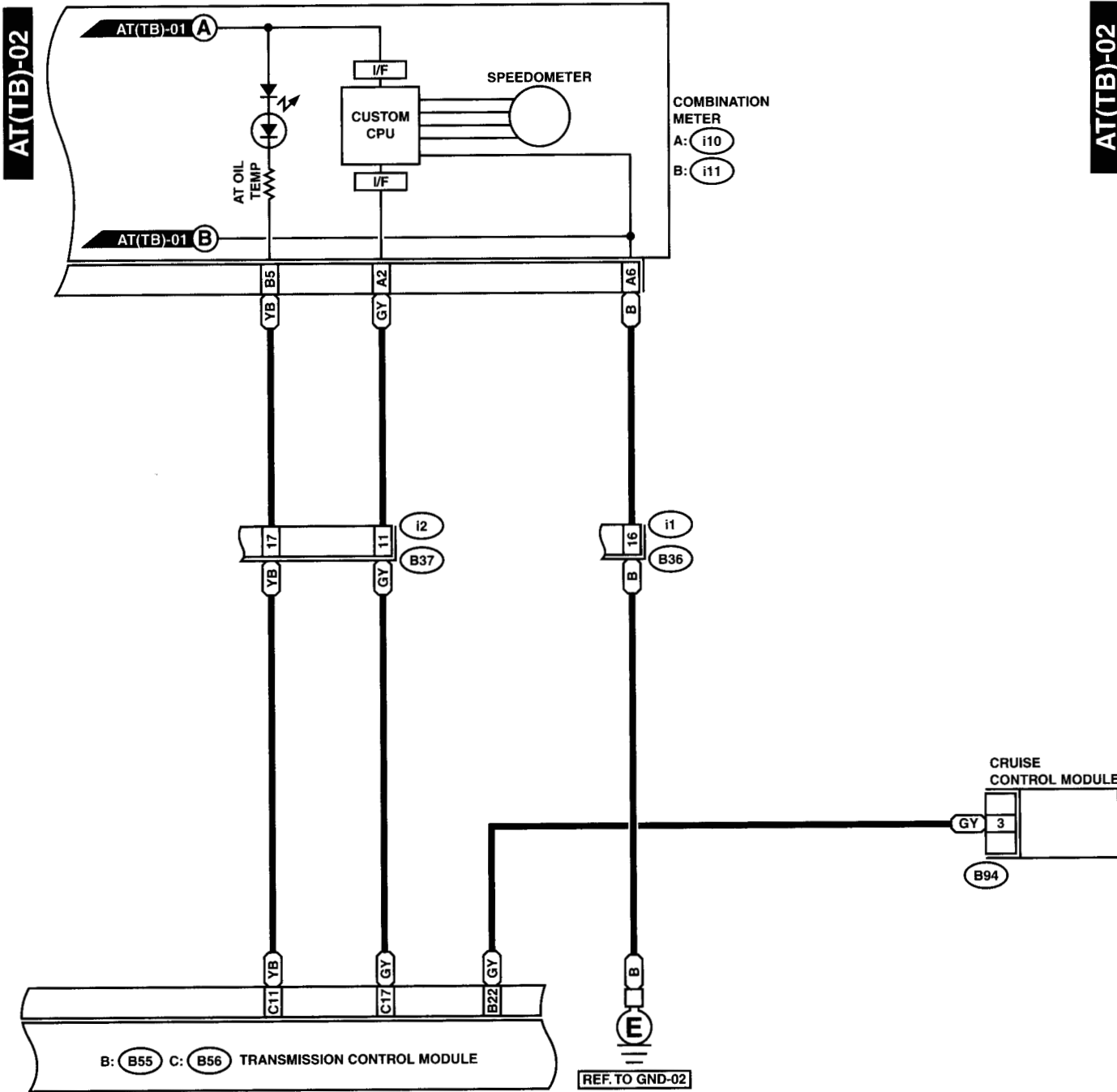

A: i10 (GREEN)

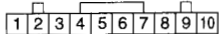

i1

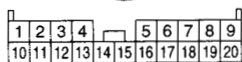

B94 (BLACK)

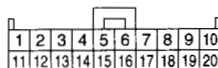

i2 (BROWN)

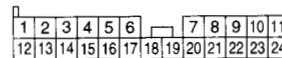

B: B55 (GRAY)

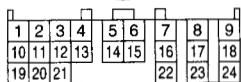

C: B56 (GREEN)

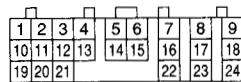

B: i11 (GREEN)

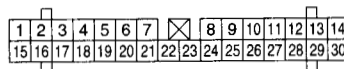

A/T CONTROL SYSTEM

WIRING SYSTEM

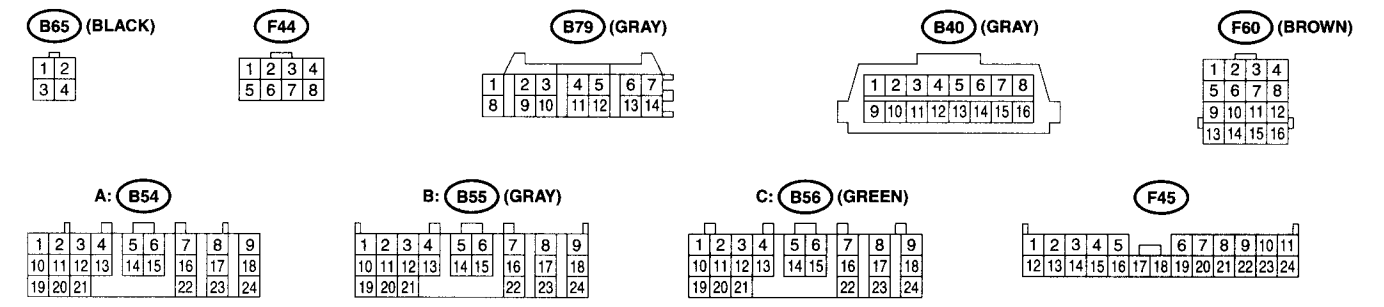
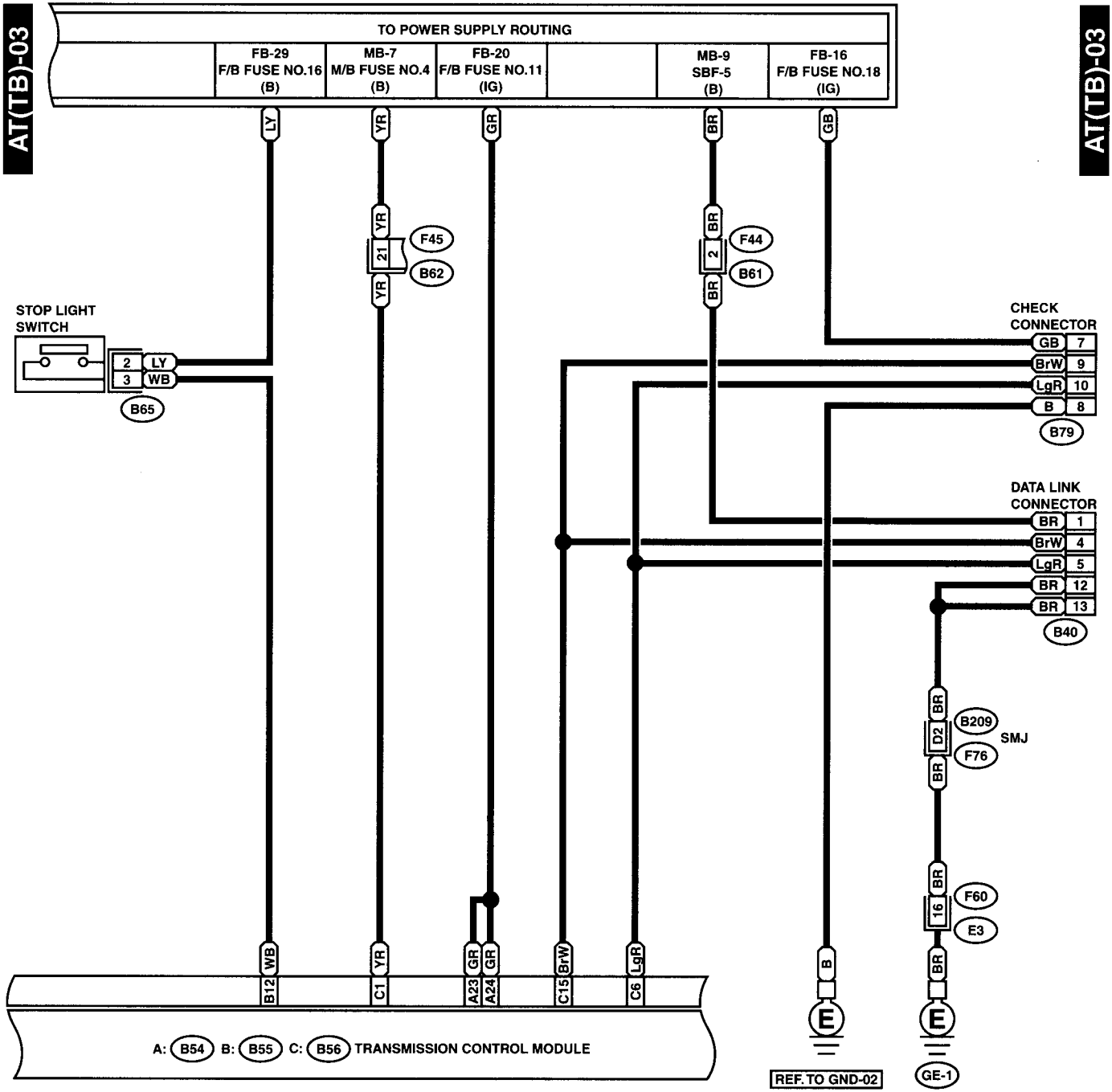

GU41-20C

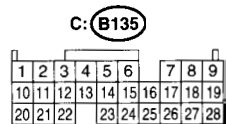
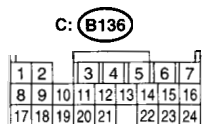
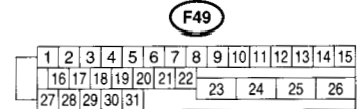
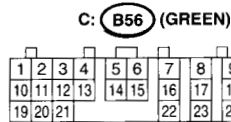
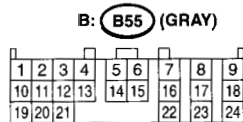
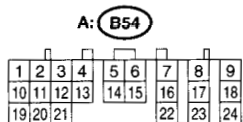
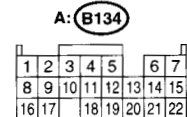
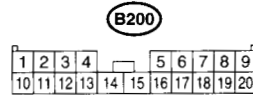
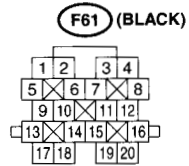
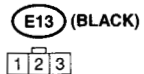
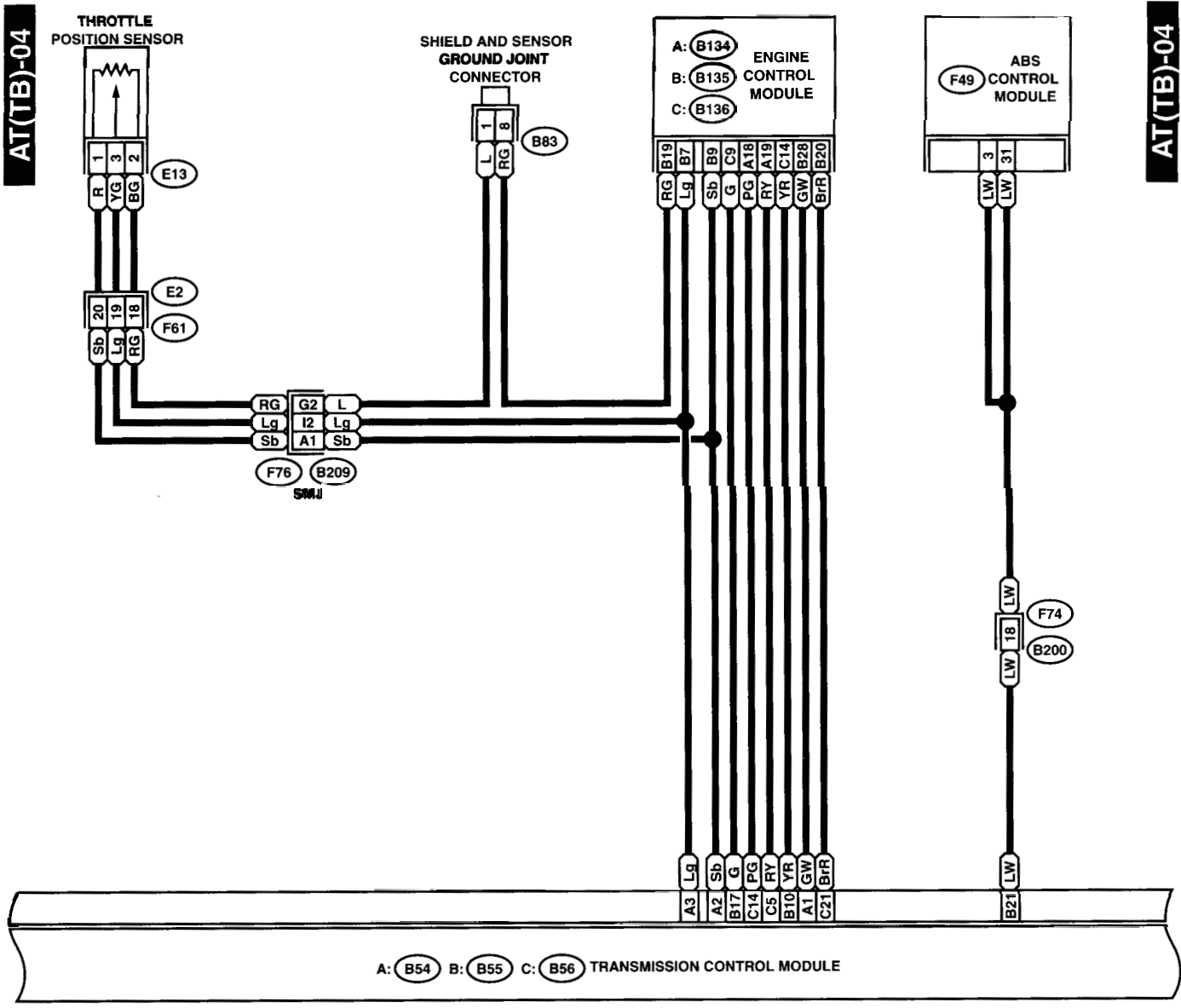

A/T CONTROL SYSTEM

WIRING SYSTEM

AT(TB)-05

AT(TB)-05

A: B54 B: B55 C: B56 TRANSMISSION CONTROL MODULE

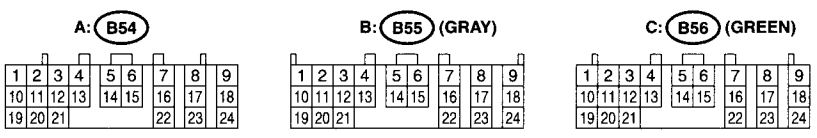
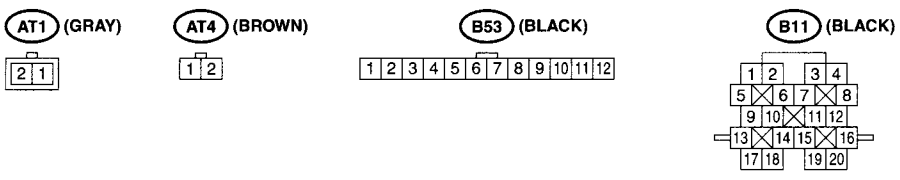
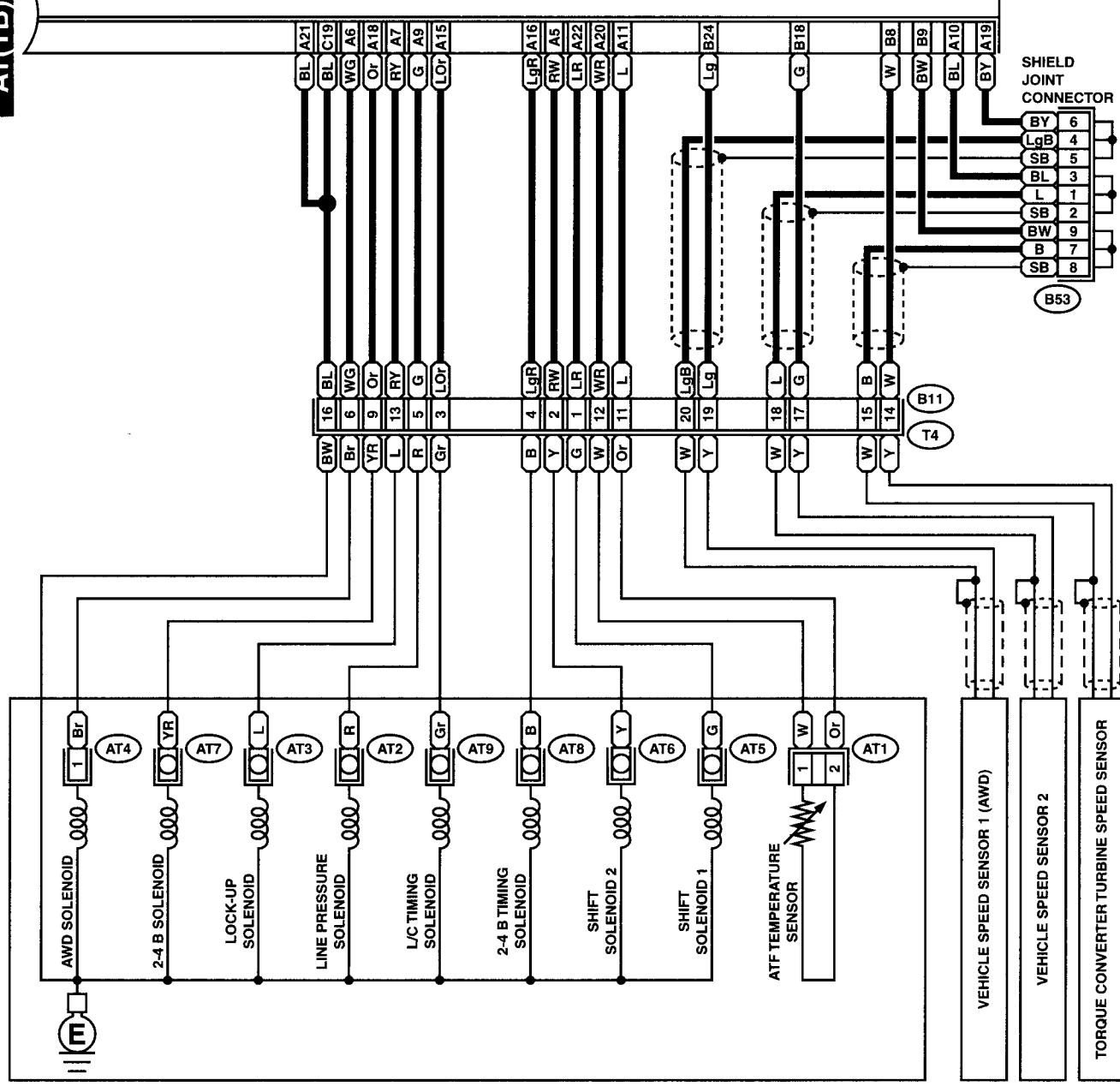

GU41-20E

2. NON-TURBO ENGINE MODEL

AT(NA)-01

AT(NA)-01

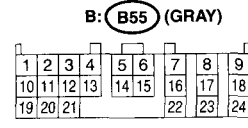
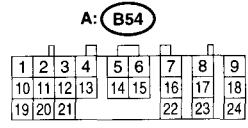
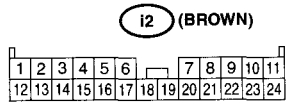
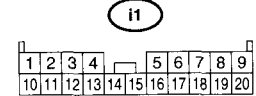
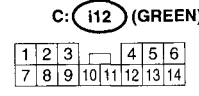
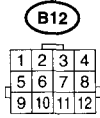
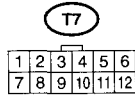
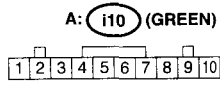
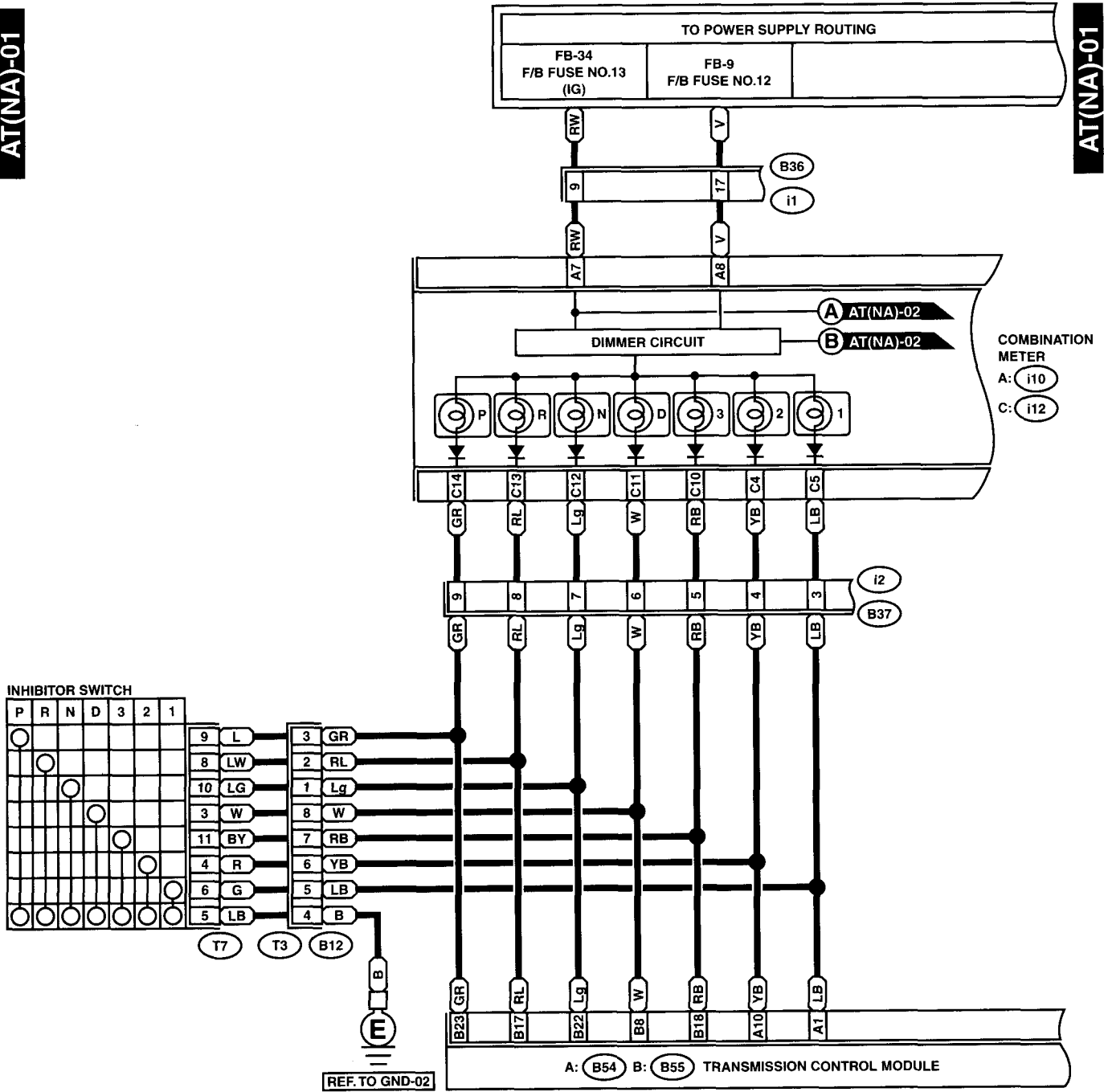

A/T CONTROL SYSTEM

WIRING SYSTEM

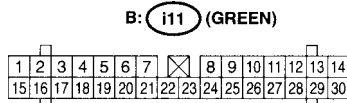
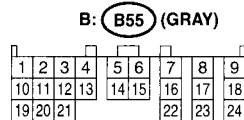
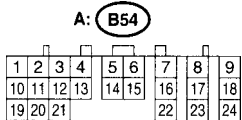
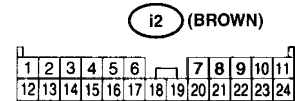
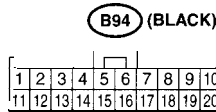
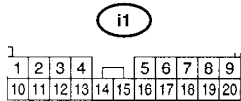
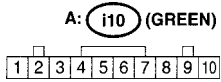
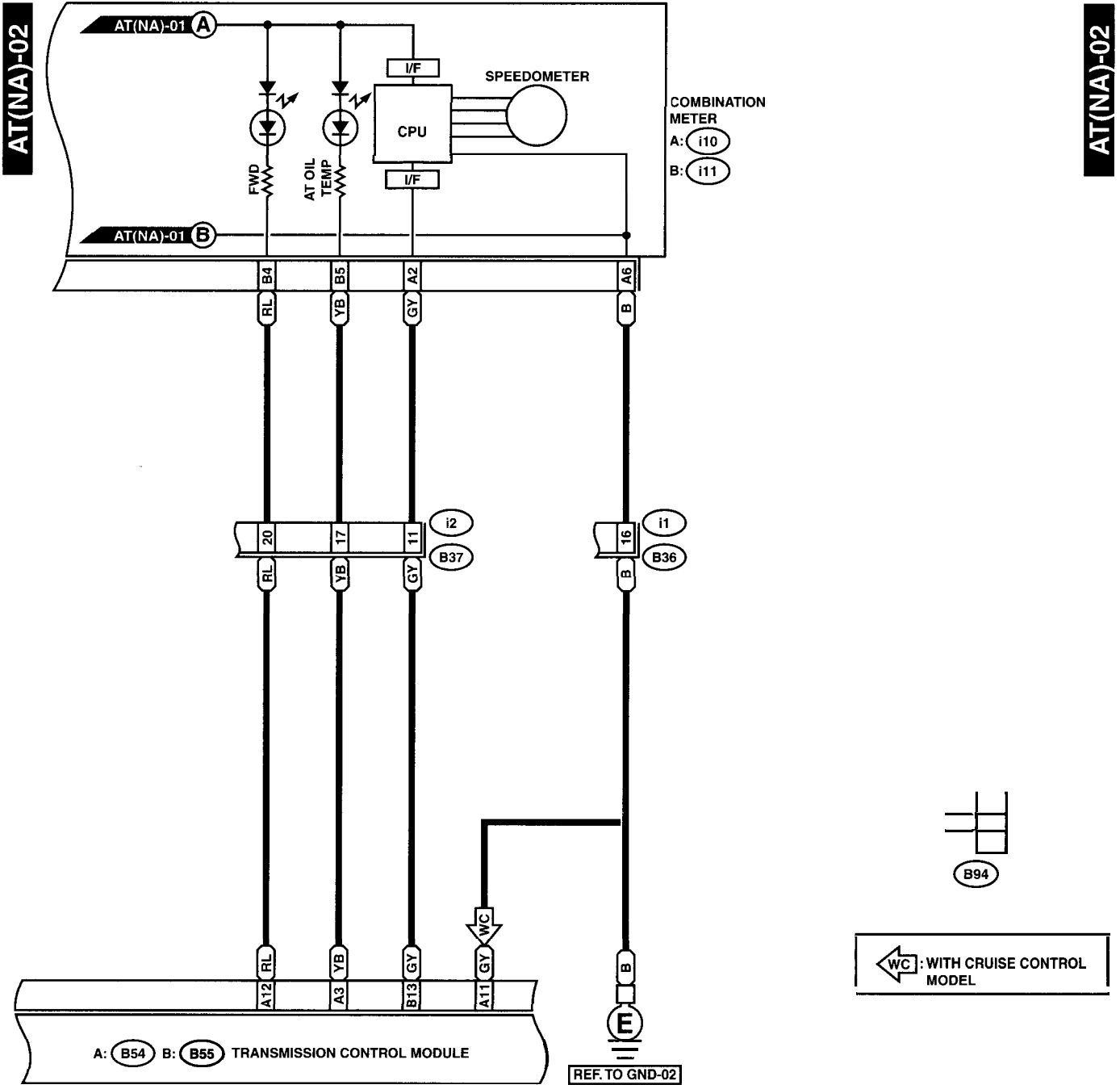

A/T CONTROL SYSTEM

WIRING SYSTEM

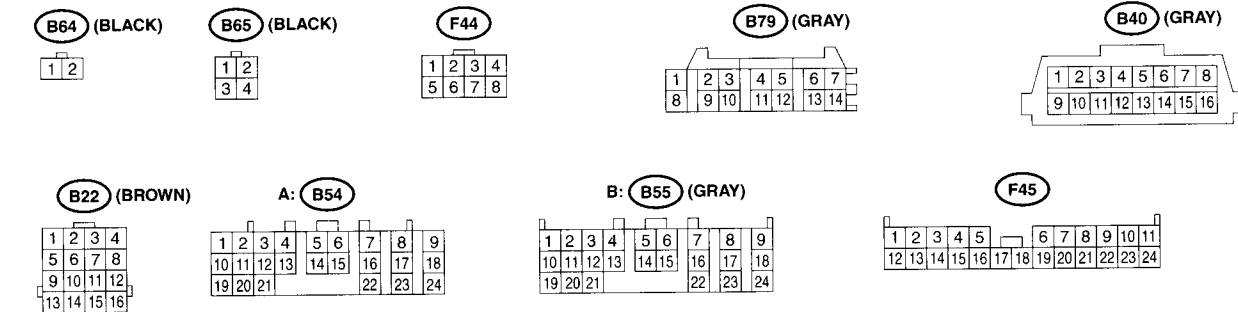
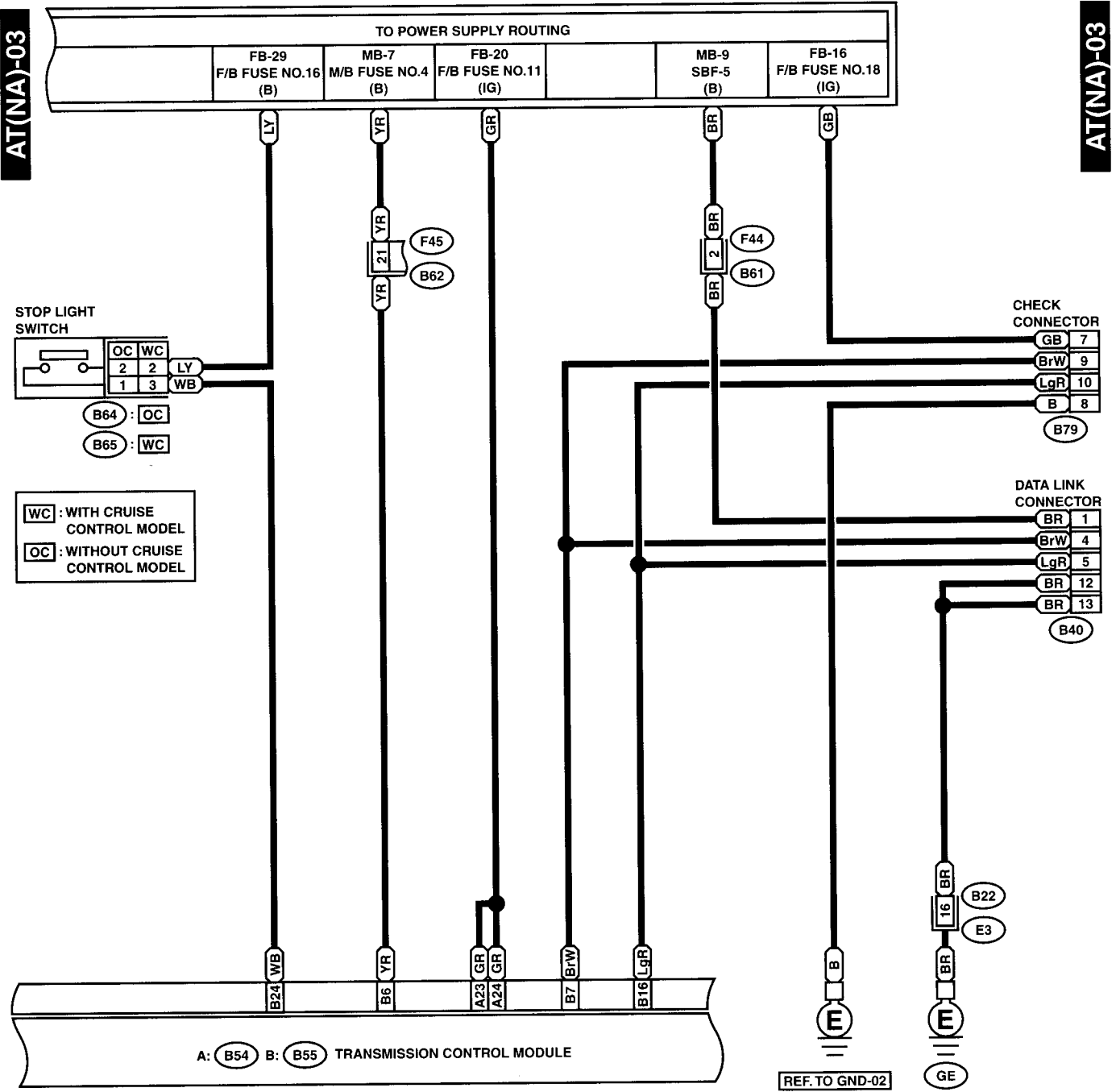

GU41-21C

A/T CONTROL SYSTEM

WIRING SYSTEM

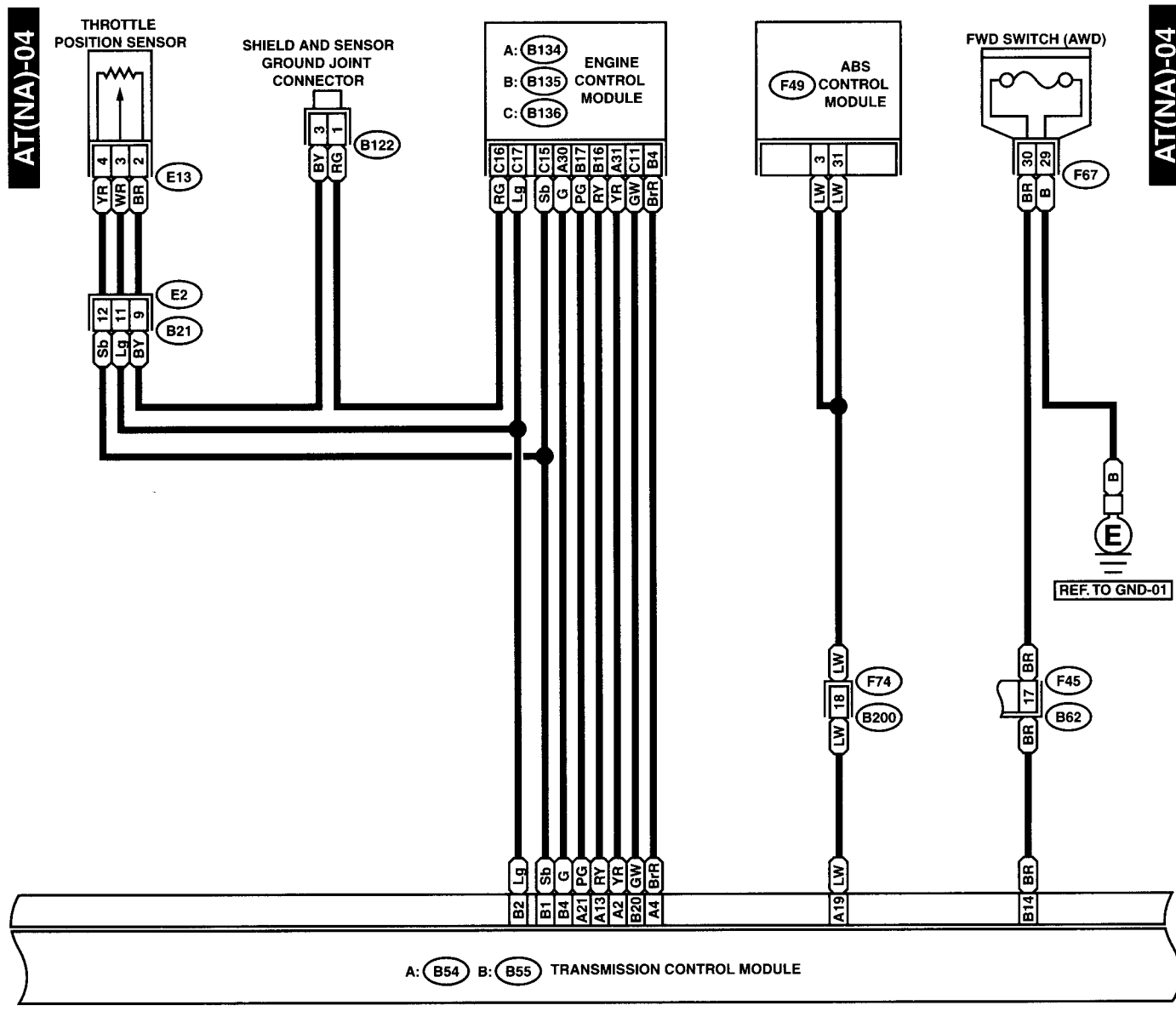

E13 (DARK BROWN)



B122



B21 (GRAY)

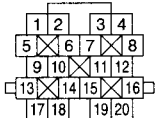

B200

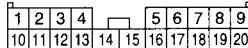

A: B54

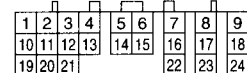

F45

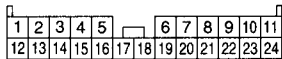

B: B55 (GRAY)

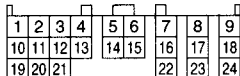

B: B135



C: B136

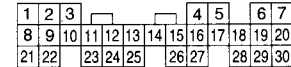

F67

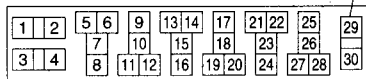

RELAY HOLDER (BLACK)

F49

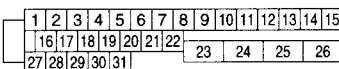

A: B134

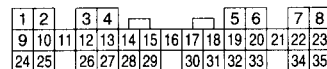

GU41-21D

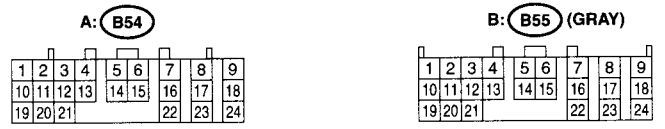
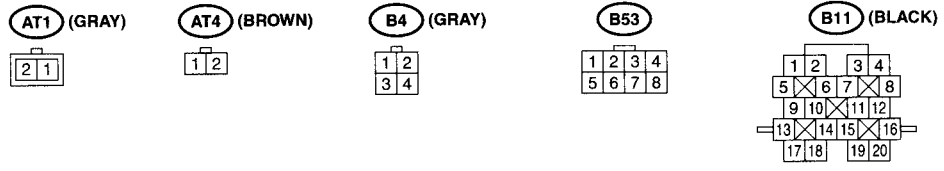
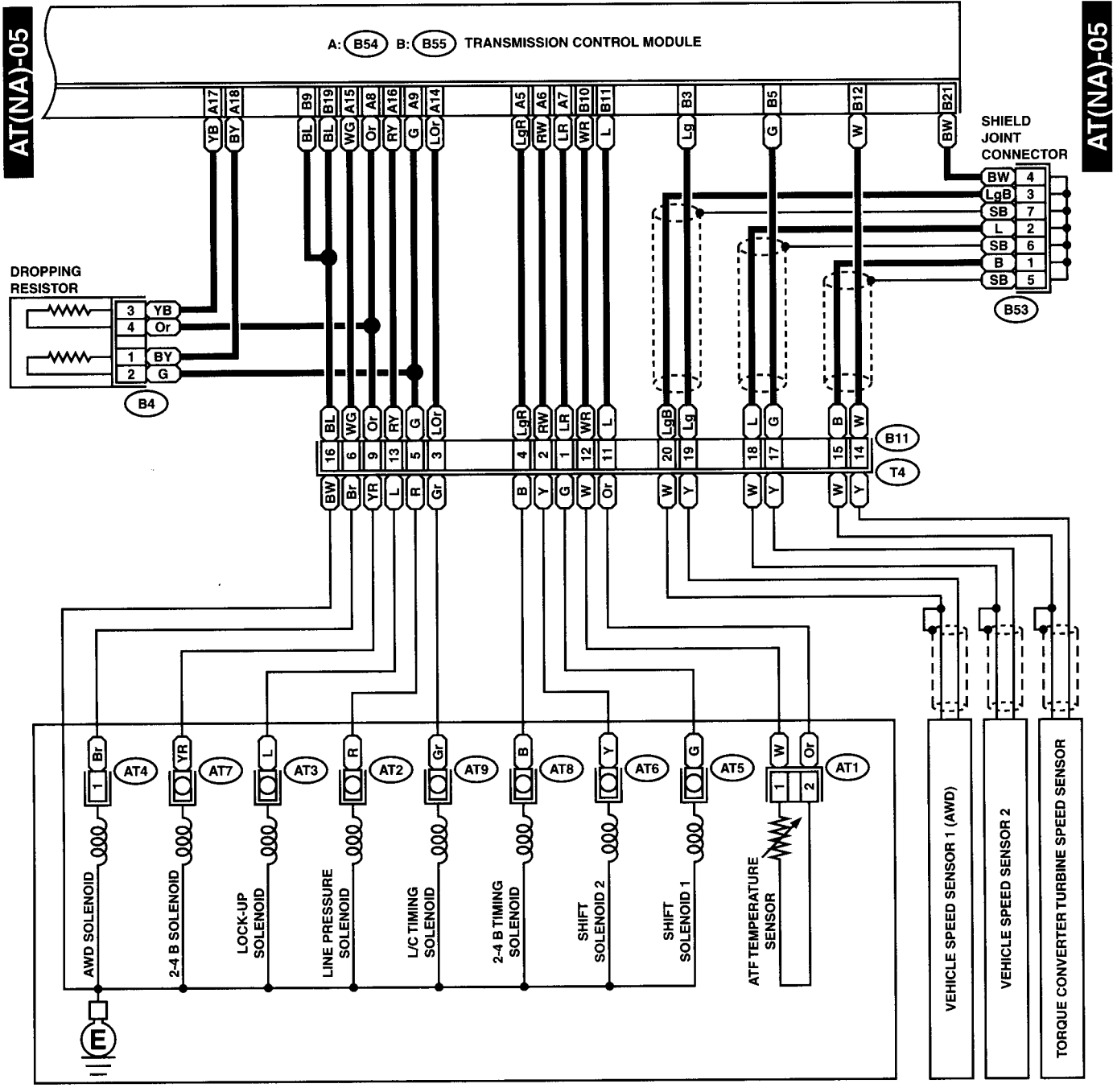

GU41-21E

A/T SHIFT LOCK CONTROL SYSTEM

WIRING SYSTEM

10.A/T Shift Lock Control System

A: SCHEMATIC

ATSL-01

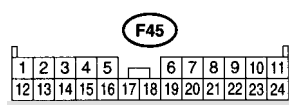
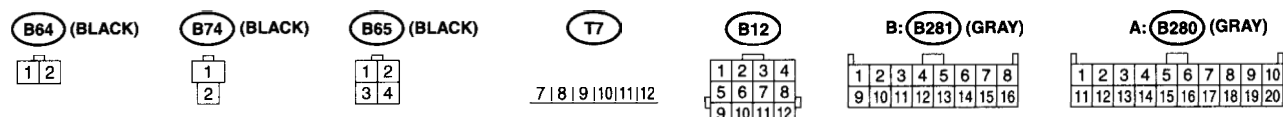
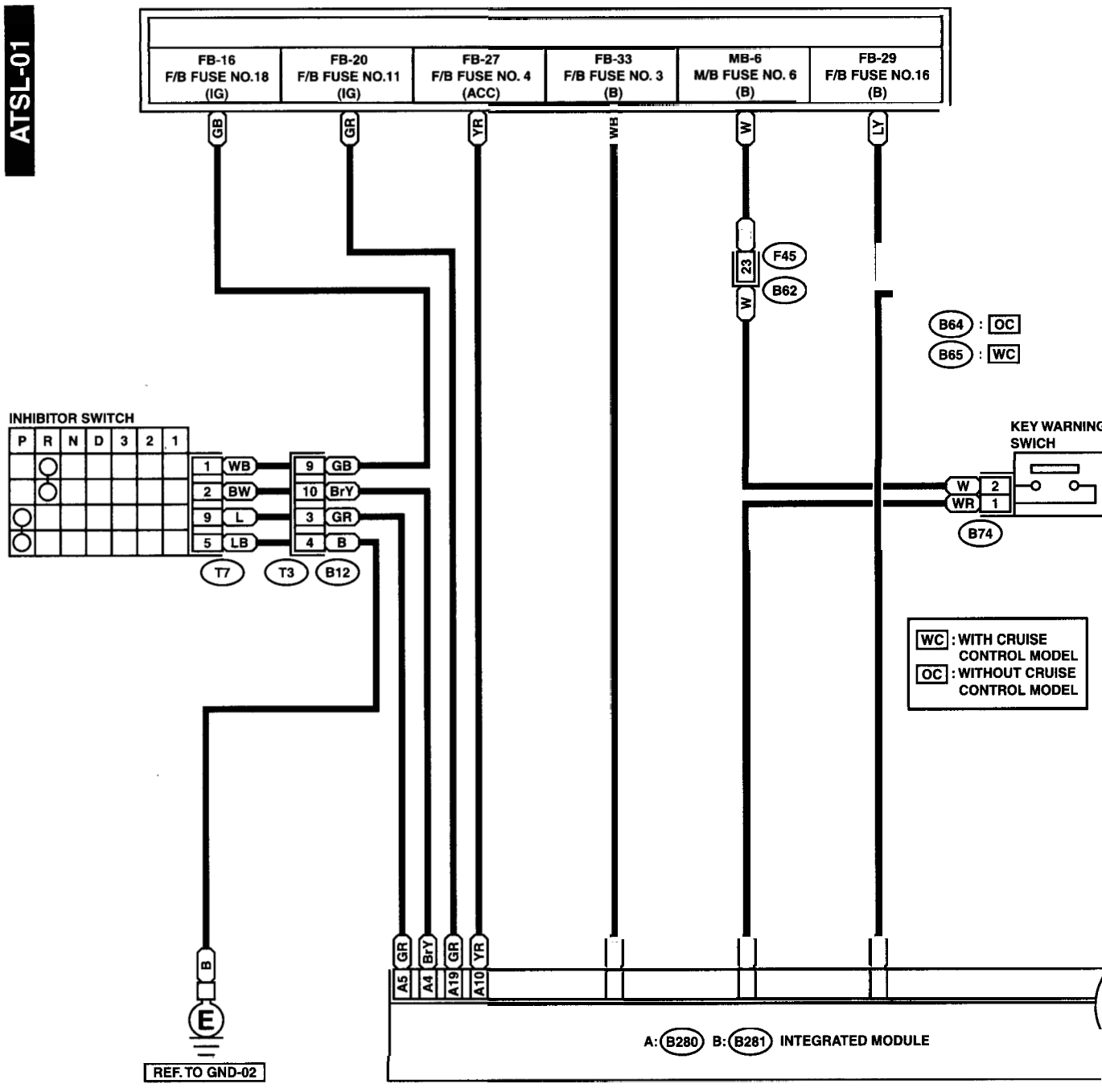

GU42-20A

A/T SHIFT LOCK CONTROL SYSTEM

WIRING SYSTEM

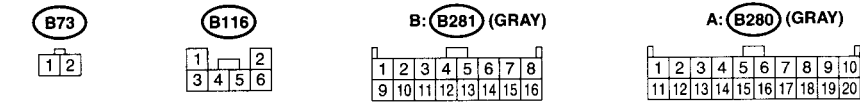
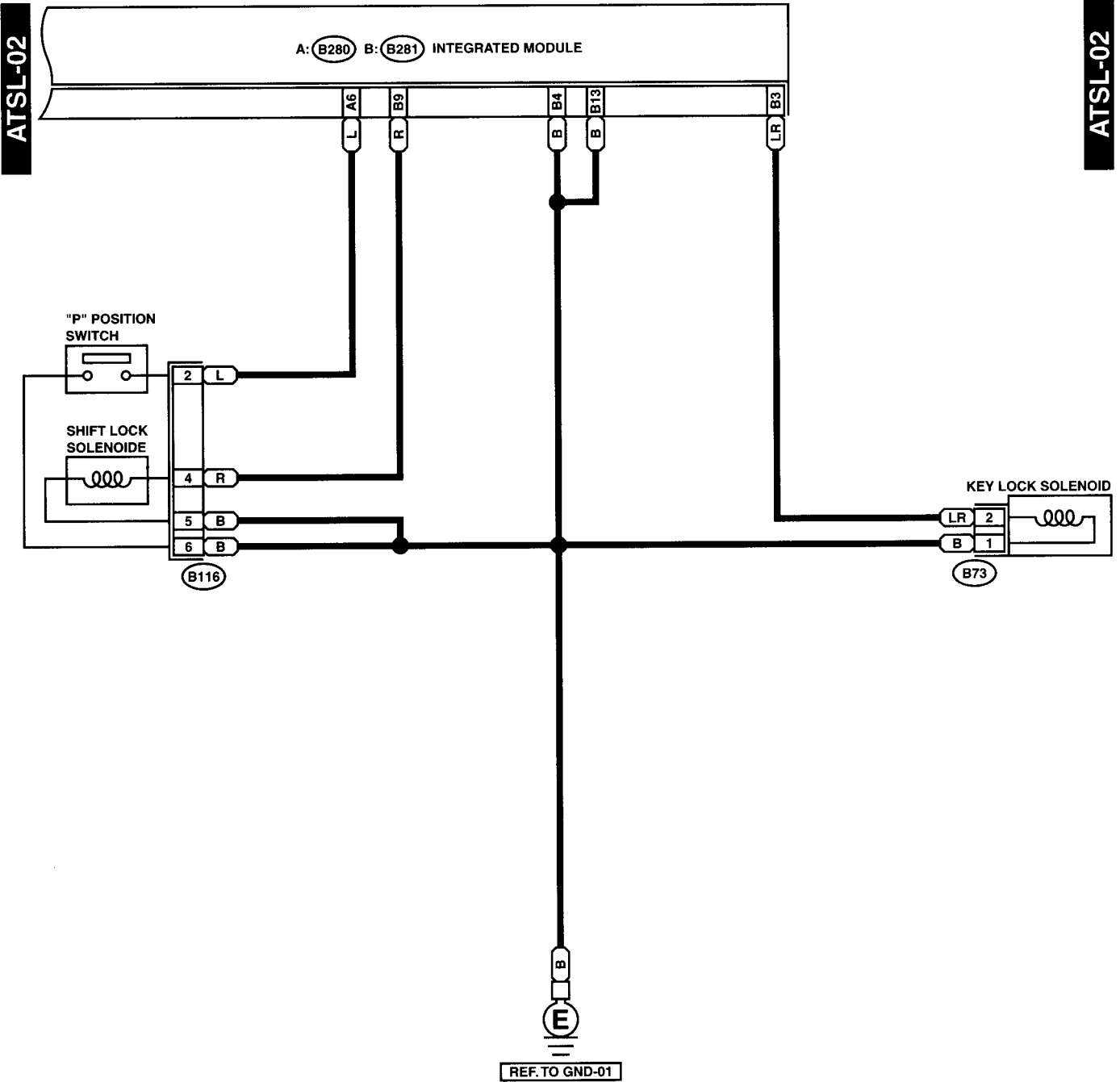

GU42-20B

AUDIO SYSTEM

WIRING SYSTEM

11. Audio System

A: SCHEMATIC

AUDIO-01

AUDIO-01

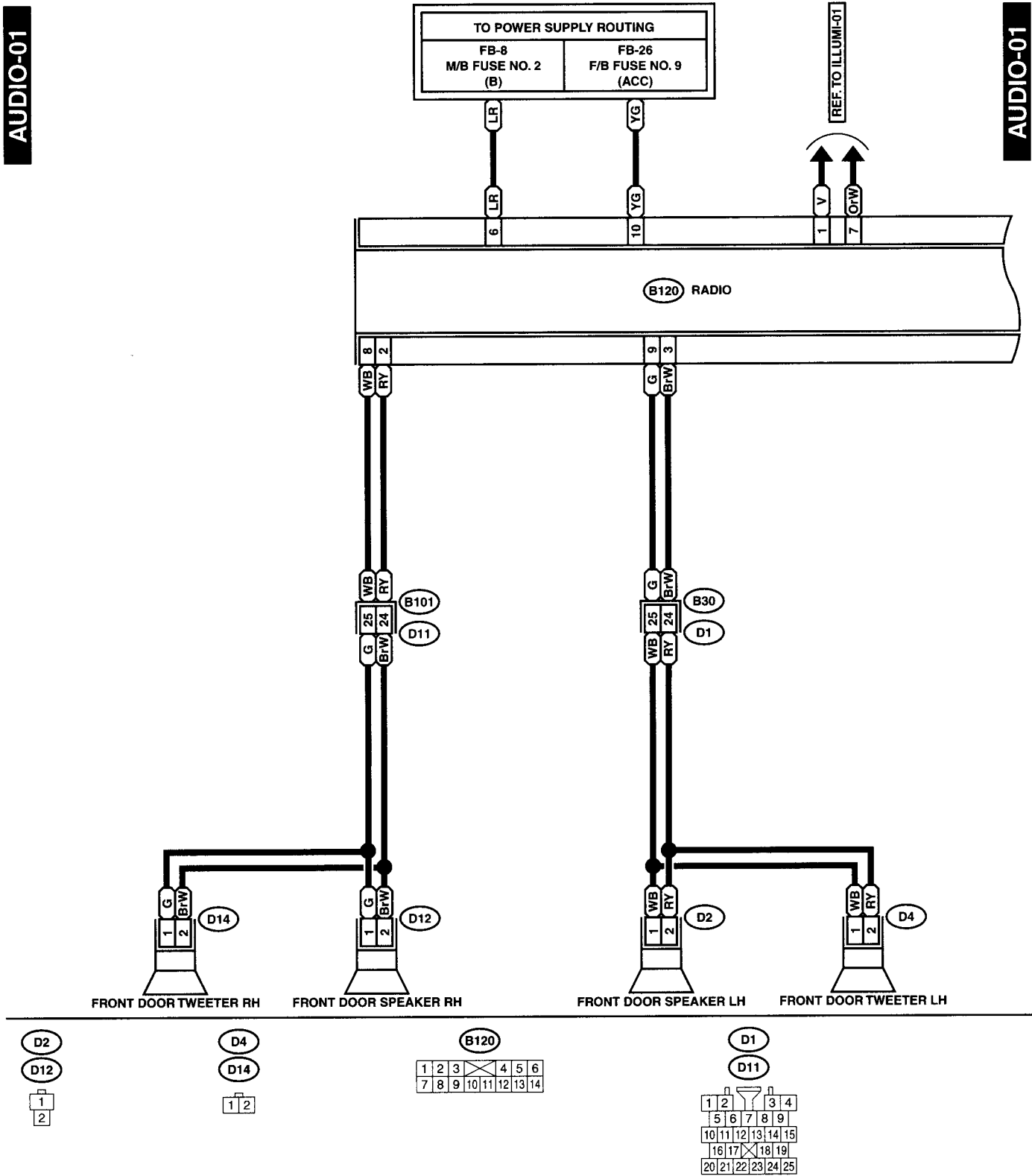

AUDIO SYSTEM

WIRING SYSTEM

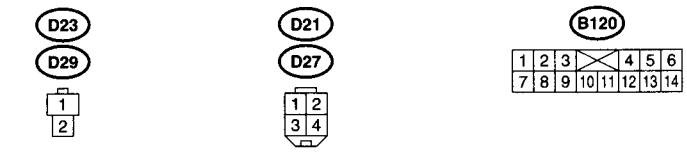
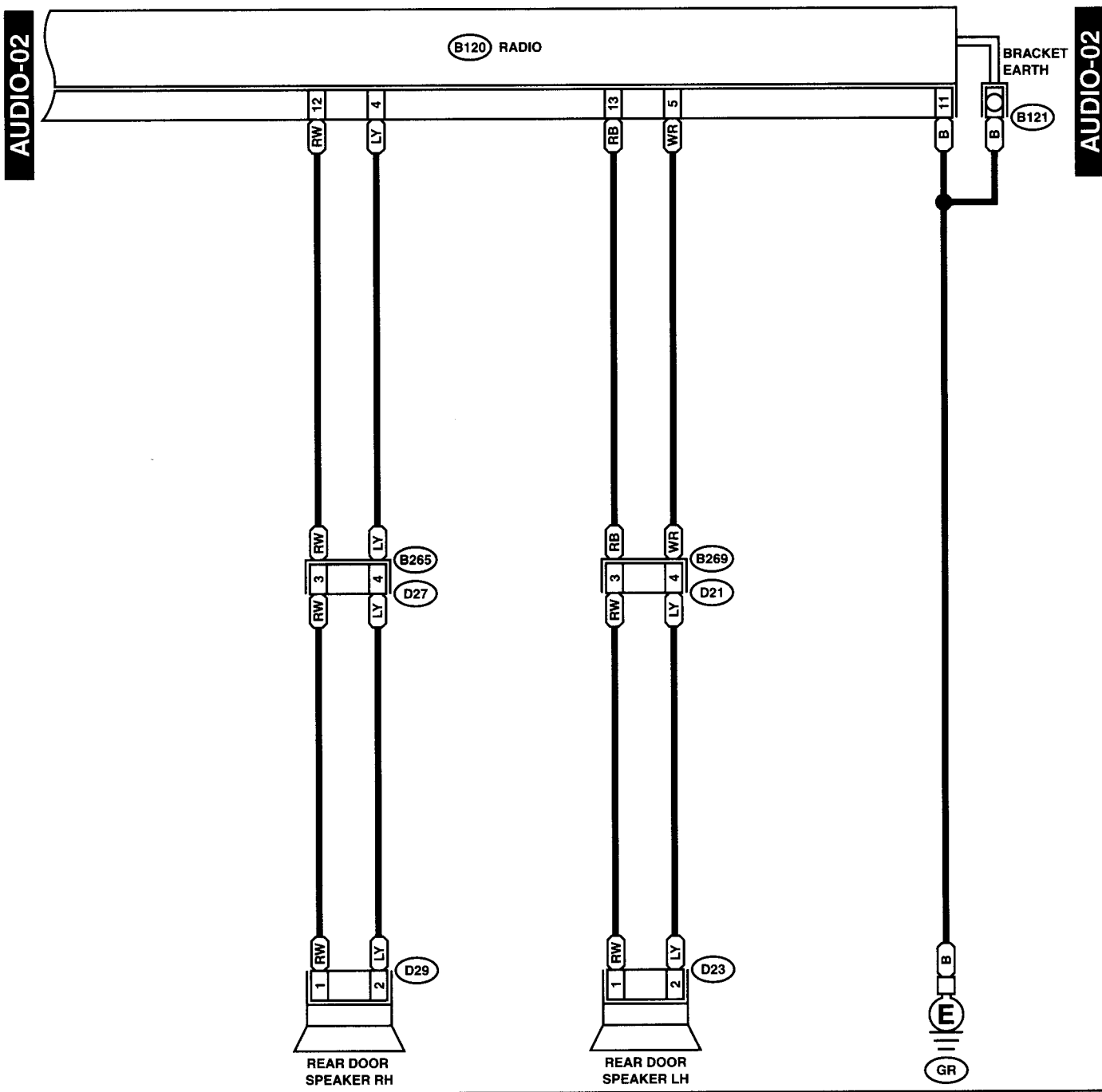

GU76-20B

CHARGING SYSTEM

WIRING SYSTEM

12. Charging System

A: SCHEMATIC

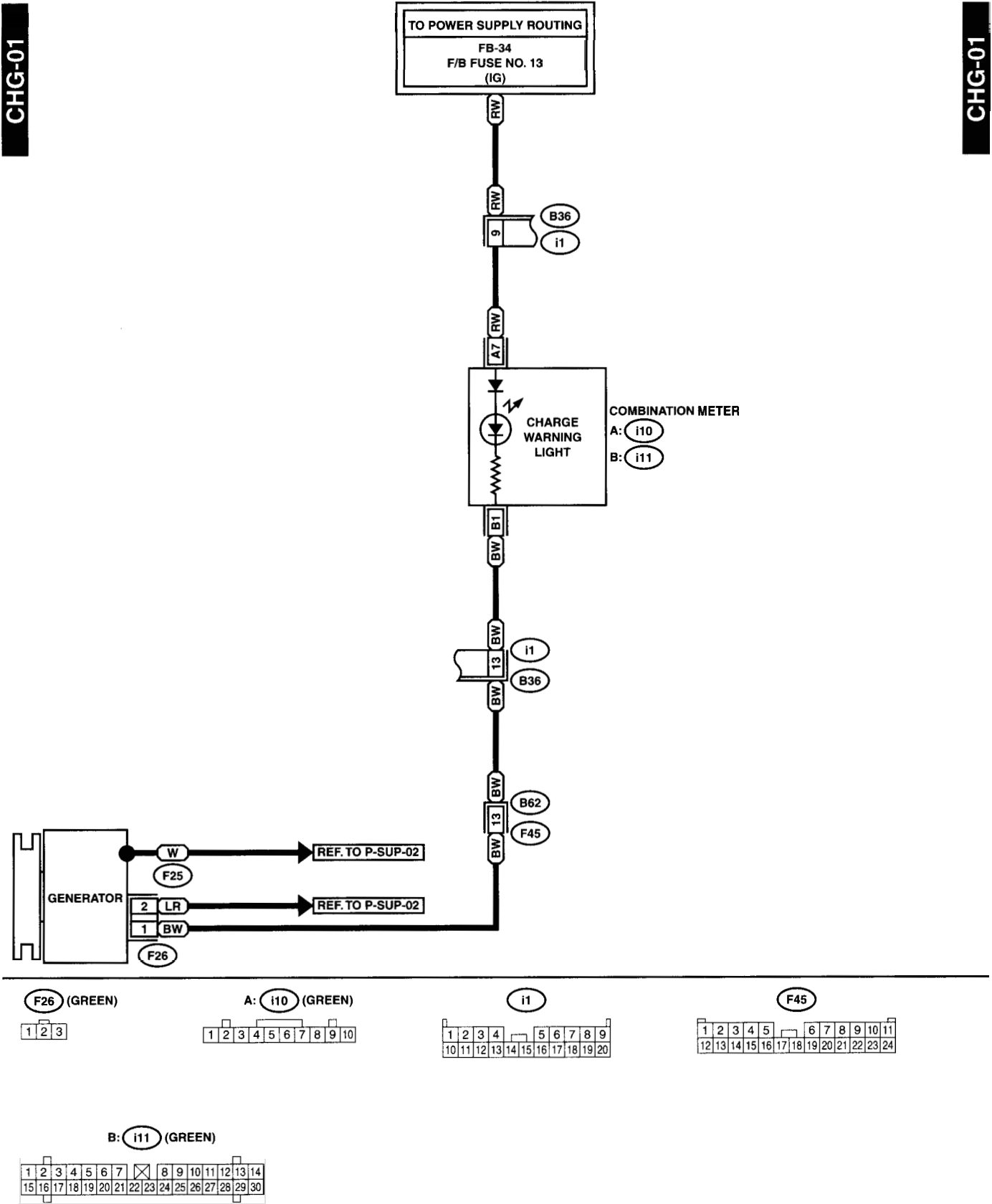

GU02-20

13.Clock System

A: SCHEMATIC

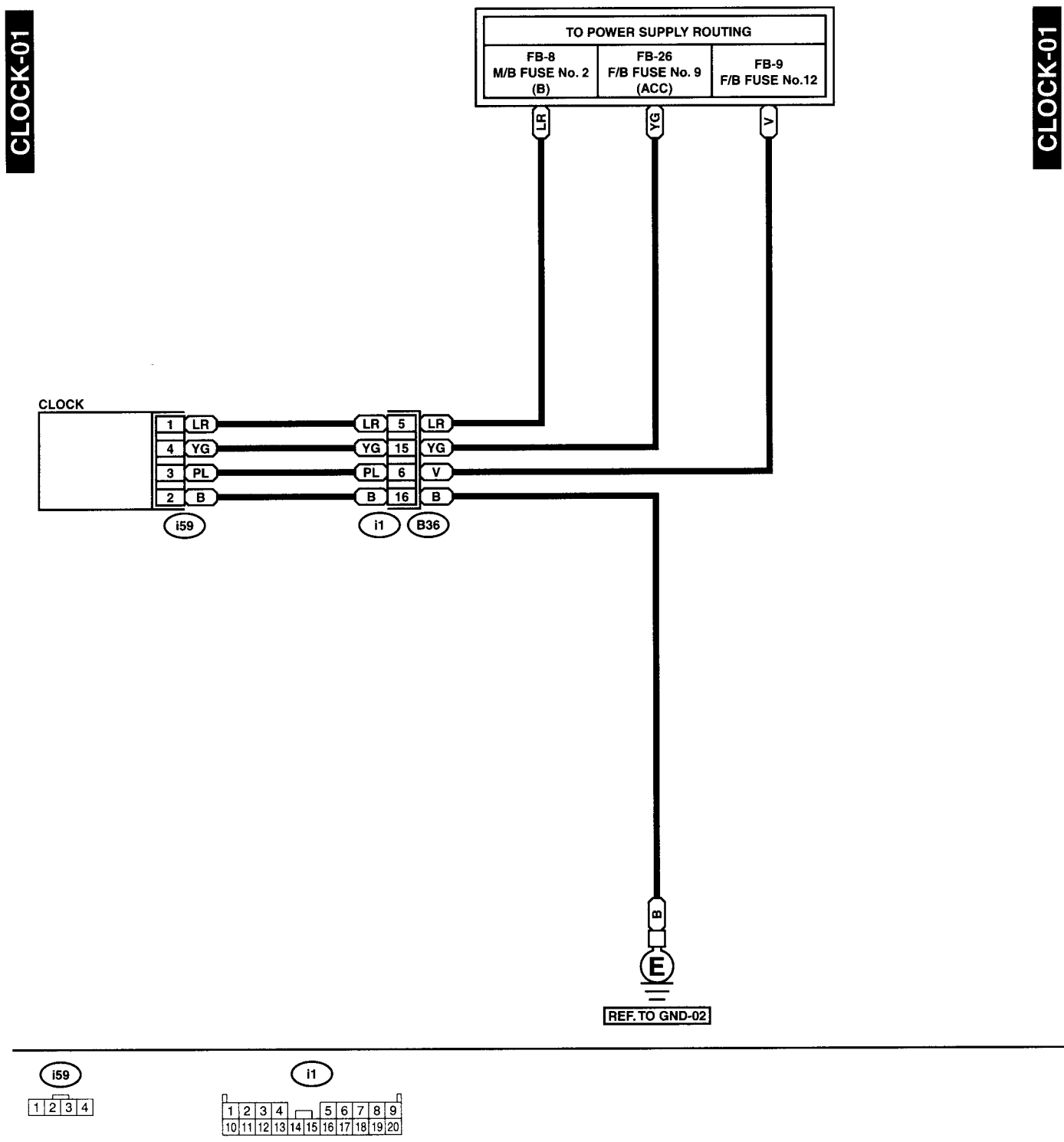

CLOCK-01

CLOCK-01

COMBINATION METER

WIRING SYSTEM

14. Combination Meter

A: SCHEMATIC

METER-01

METER-01

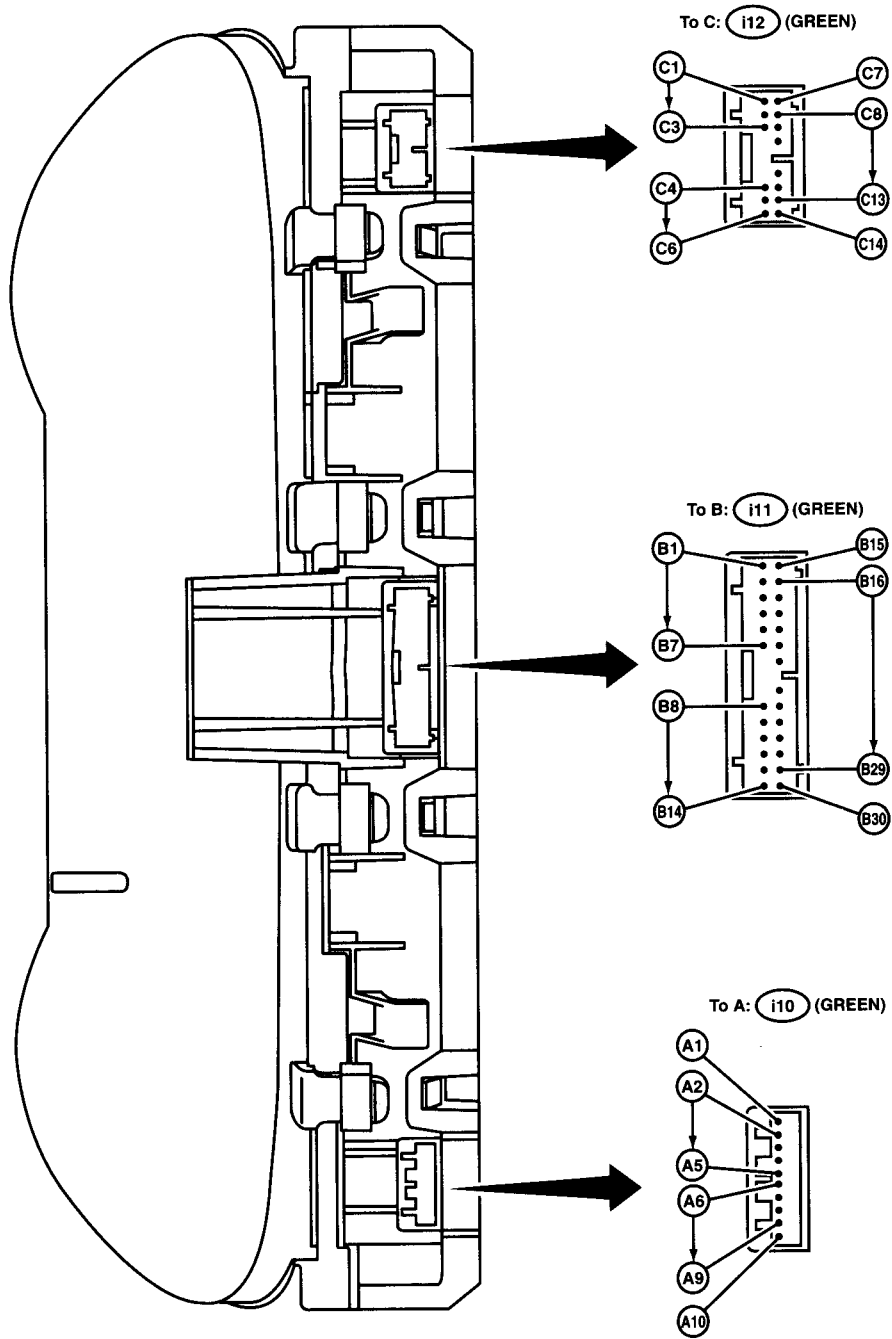

COMBINATION METER

WIRING SYSTEM

METER-02

METER-02

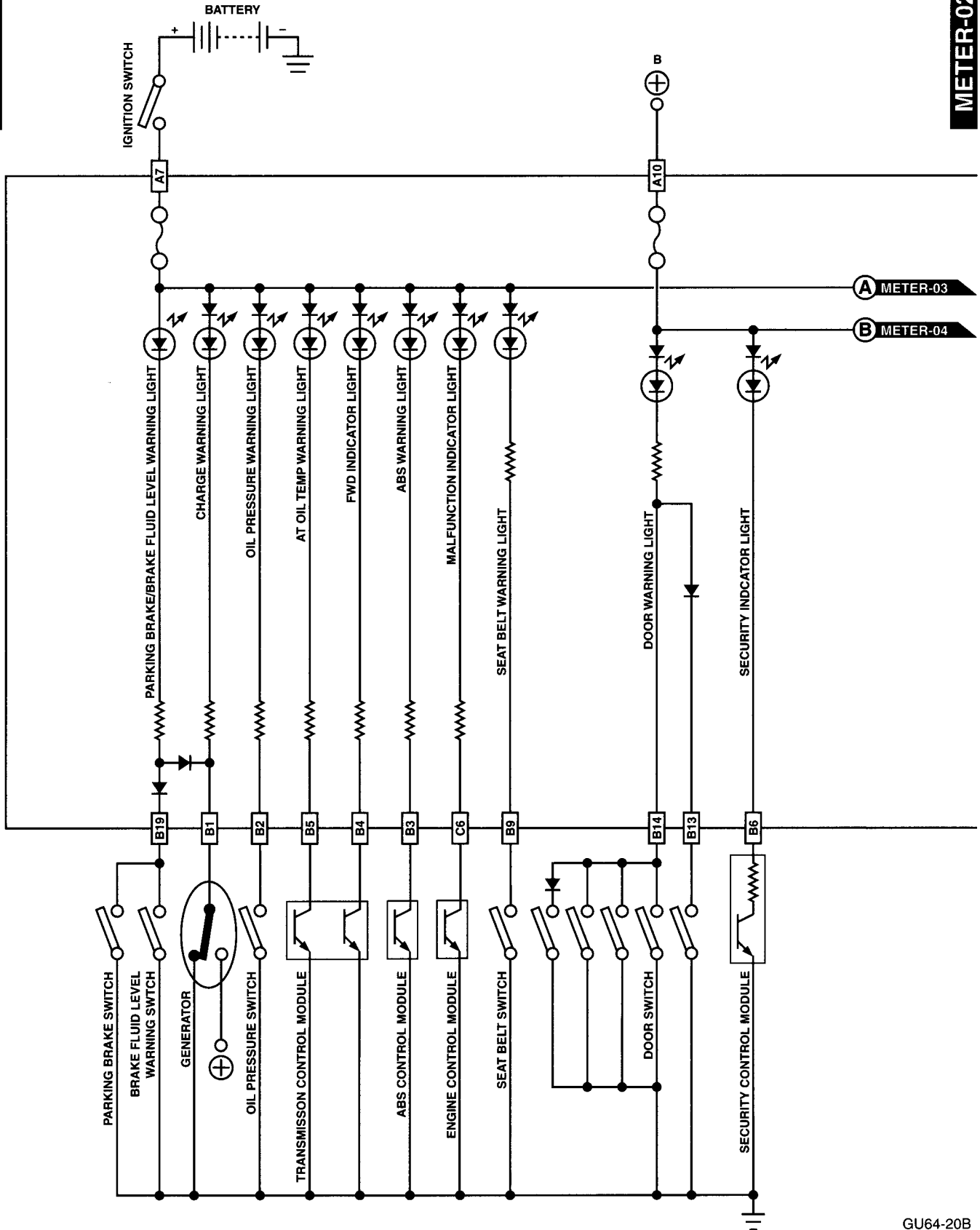

GU64-20B

COMBINATION METER

WIRING SYSTEM

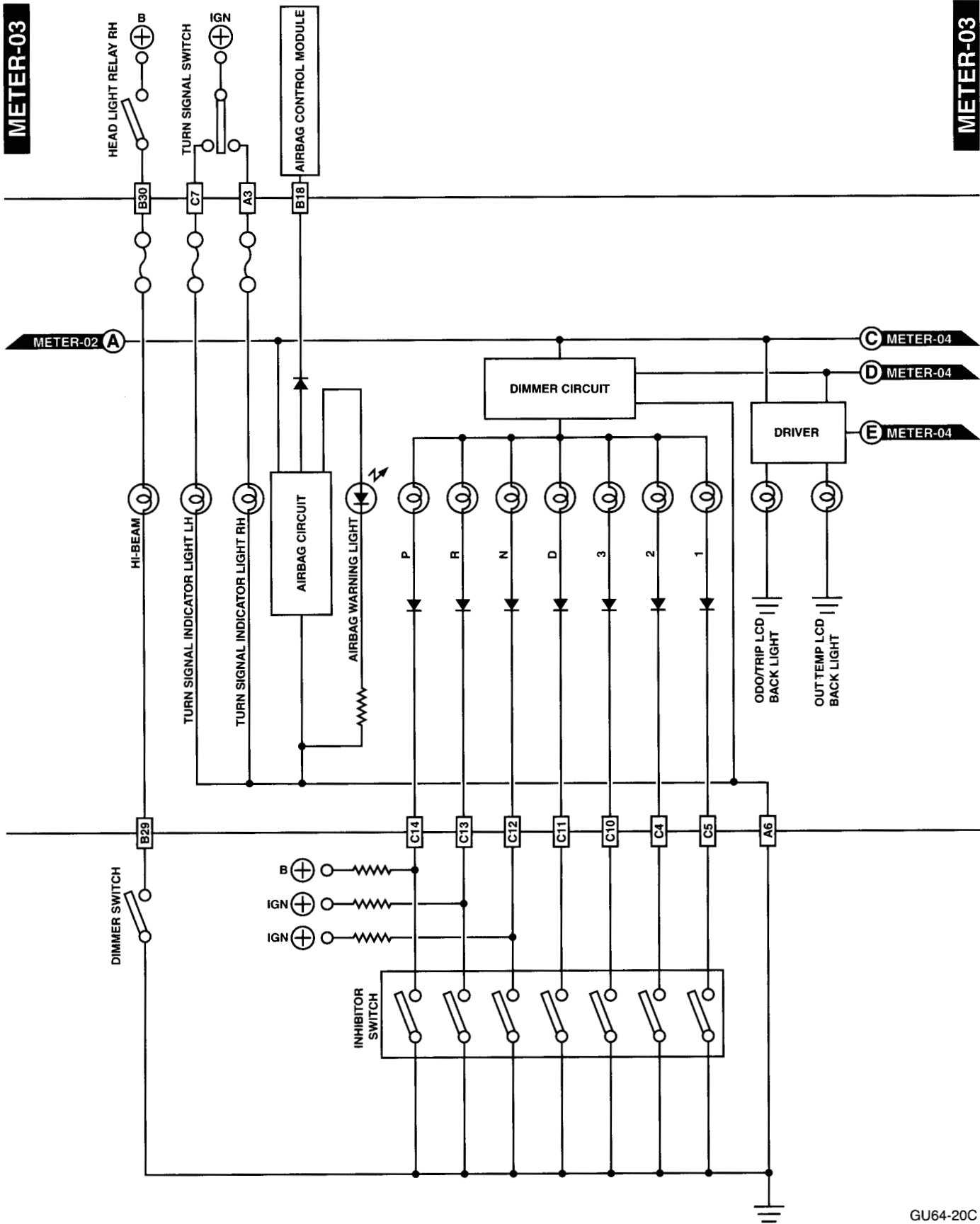

GU64-20C

COMBINATION METER

WIRING SYSTEM

METER-04

METER-04

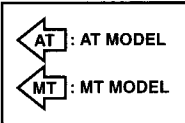
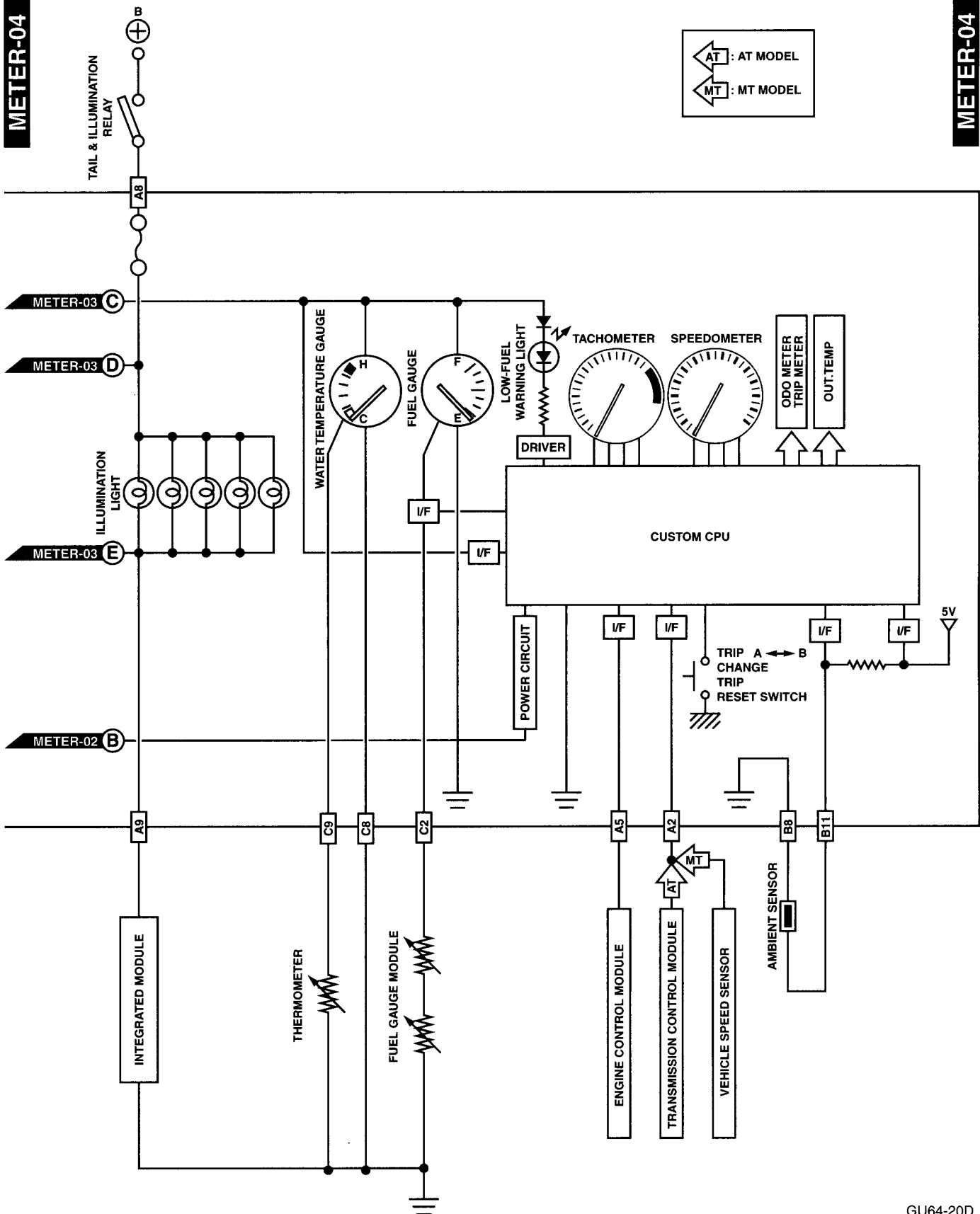

GU64-20D

COMPASS MIRROR SYSTEM

WIRING SYSTEM

15. Compass Mirror System

A: SCHEMATIC

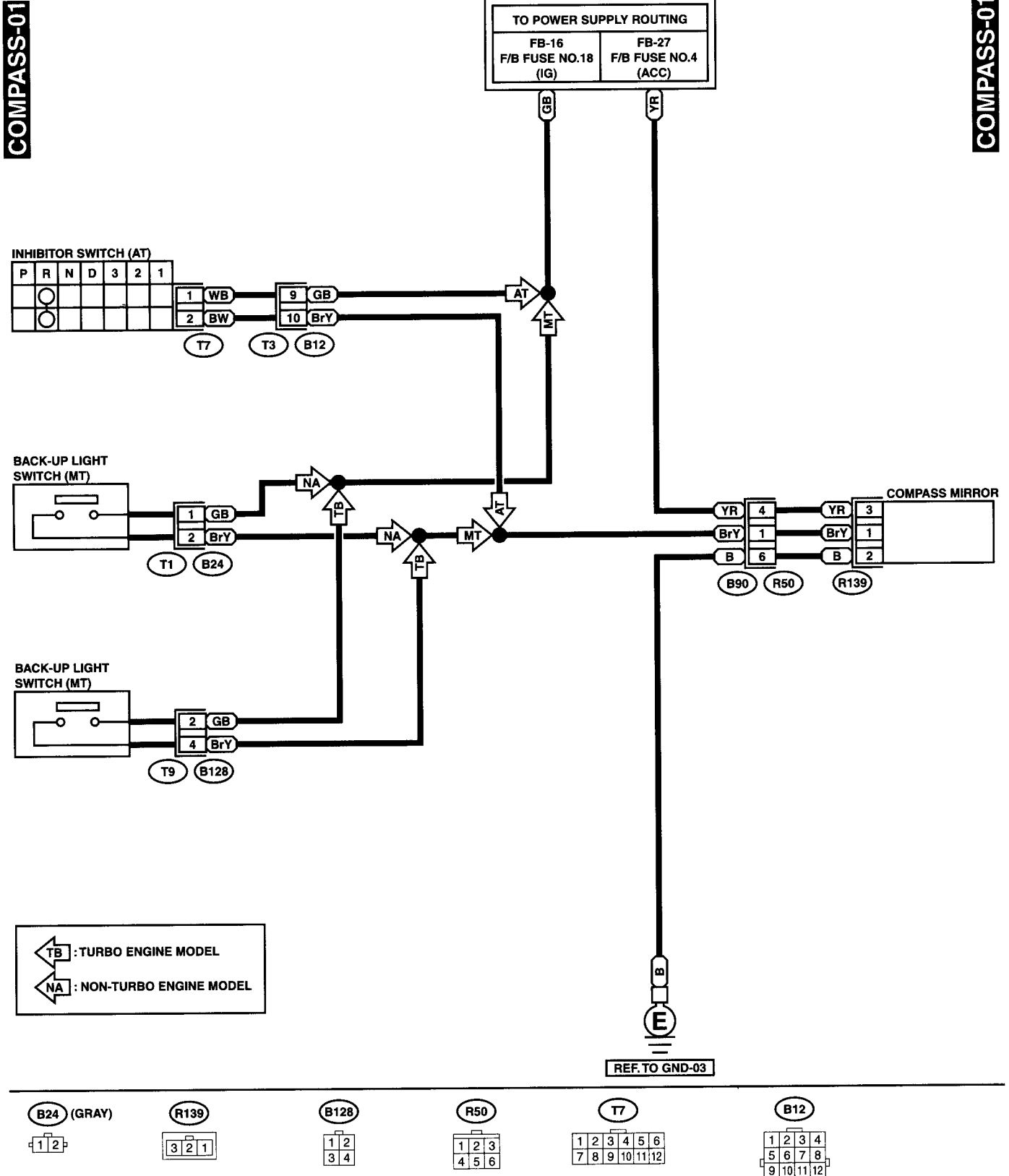

16. Cruise Control System

A: SCHEMATIC

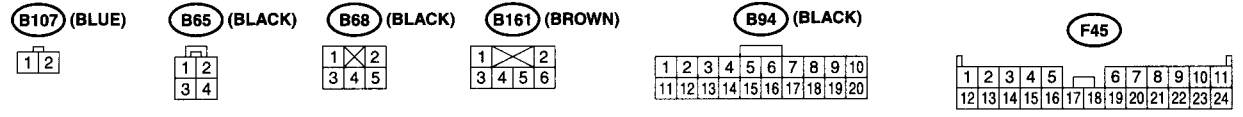
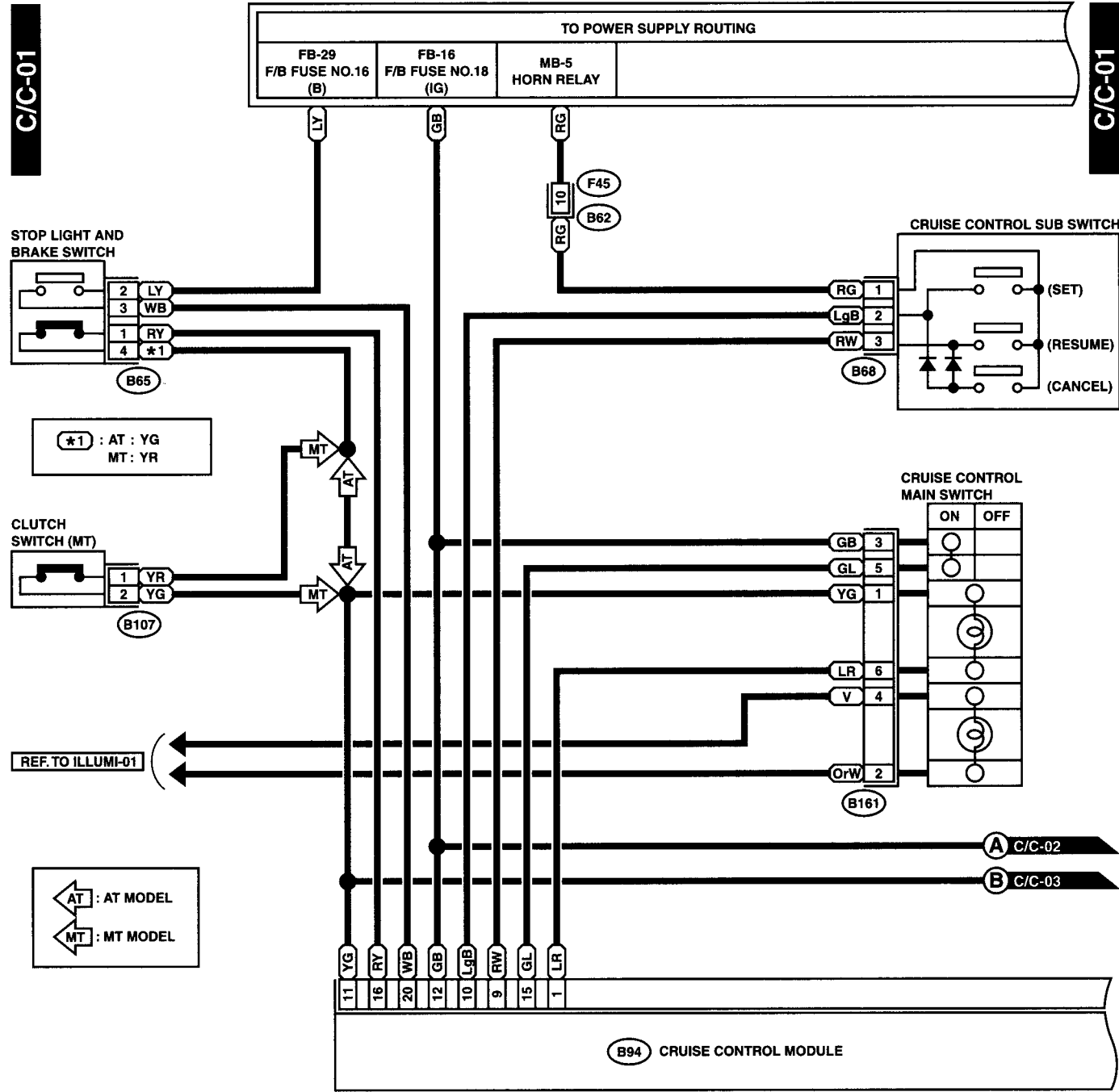

CRUISE CONTROL SYSTEM

WIRING SYSTEM

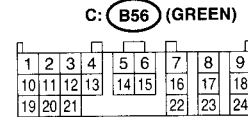
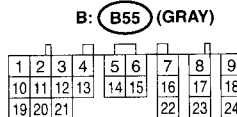
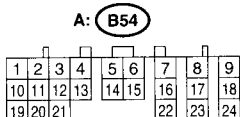
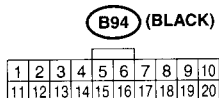
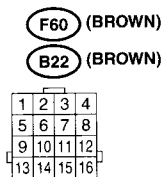
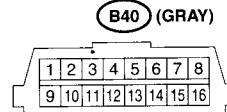
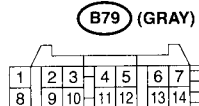
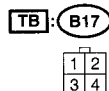
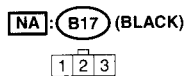
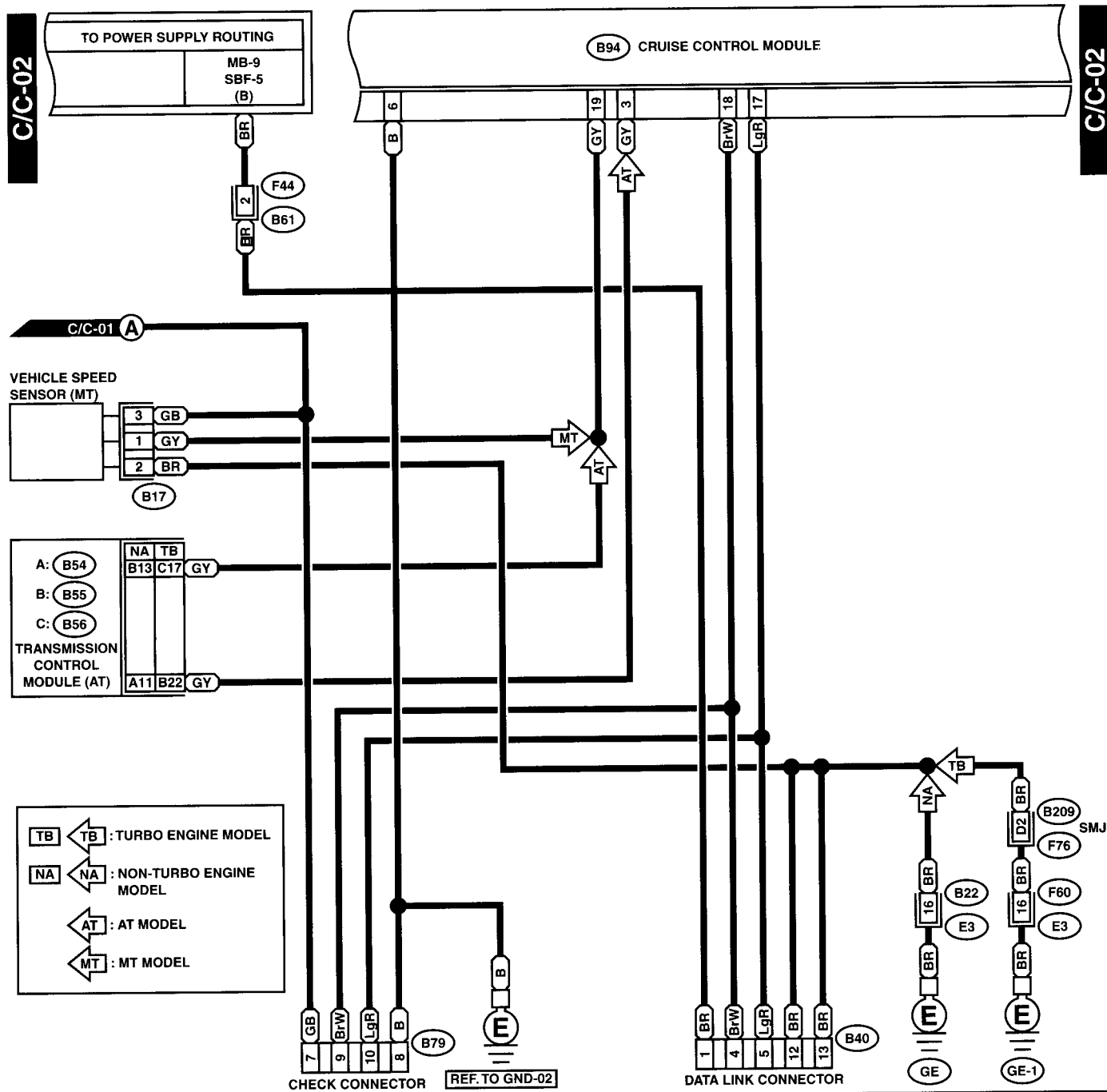

GU71-20B

CRUISE CONTROL SYSTEM

WIRING SYSTEM

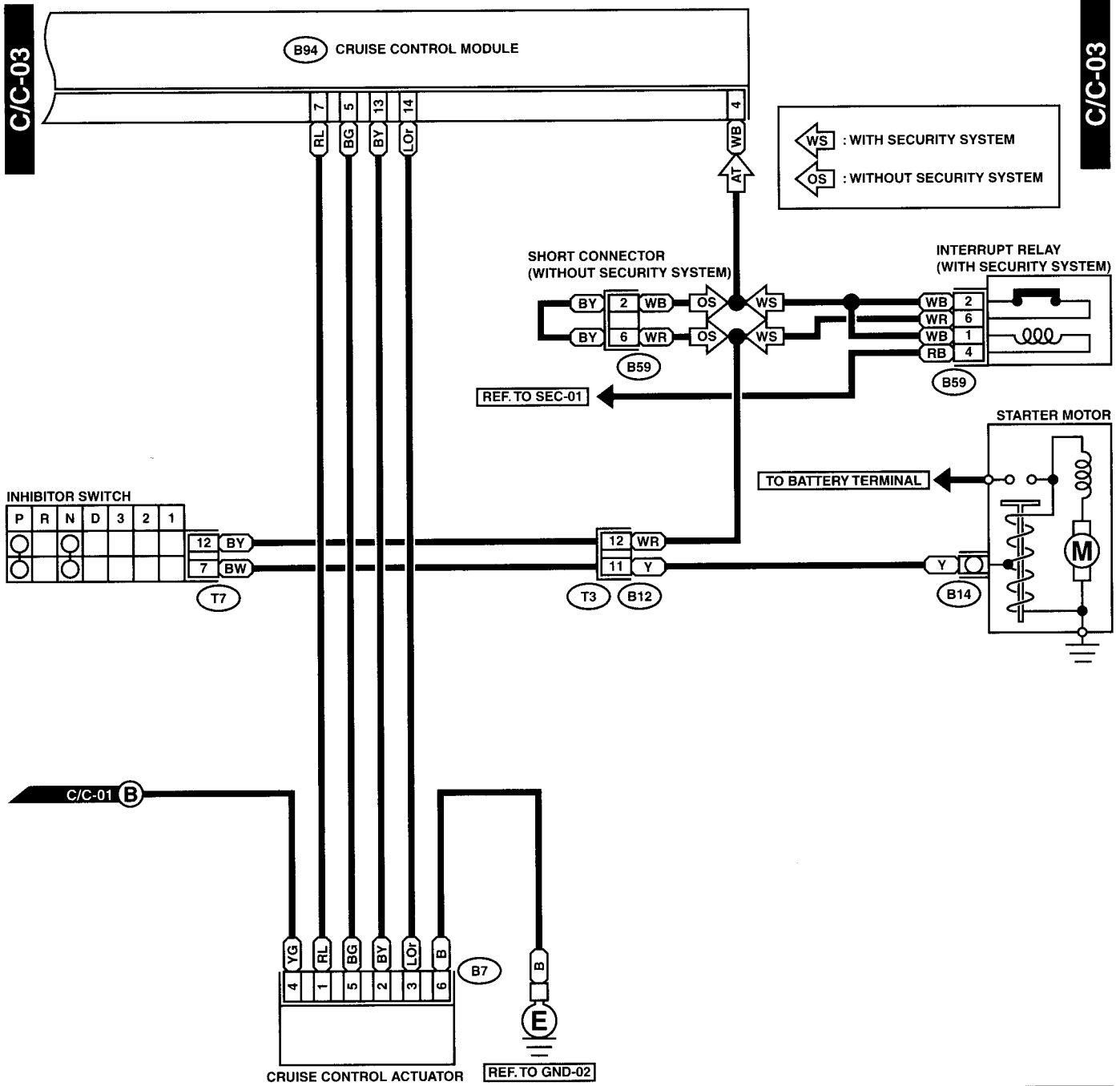

B7 (BLACK)



B59



B12



T7



B94 (BLACK)

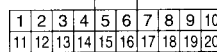

GU71-20C

DOOR LOCK SYSTEM

WIRING SYSTEM

17. Door Lock System

A: SCHEMATIC

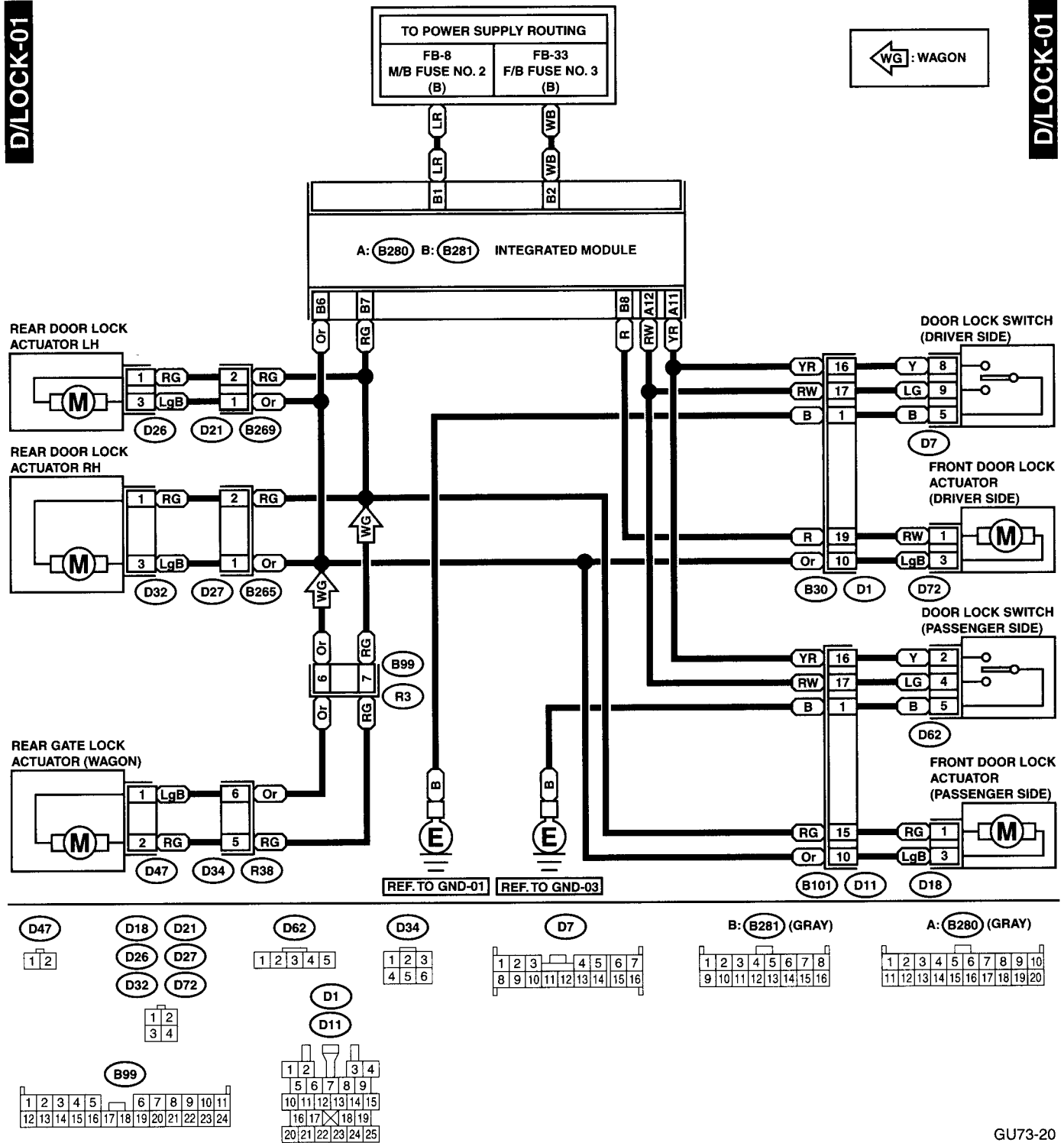

GU73-20

18.Engine Coolant Temperature Gauge System

A: SCHEMATIC

C/TEMP-01

C/TEMP-01

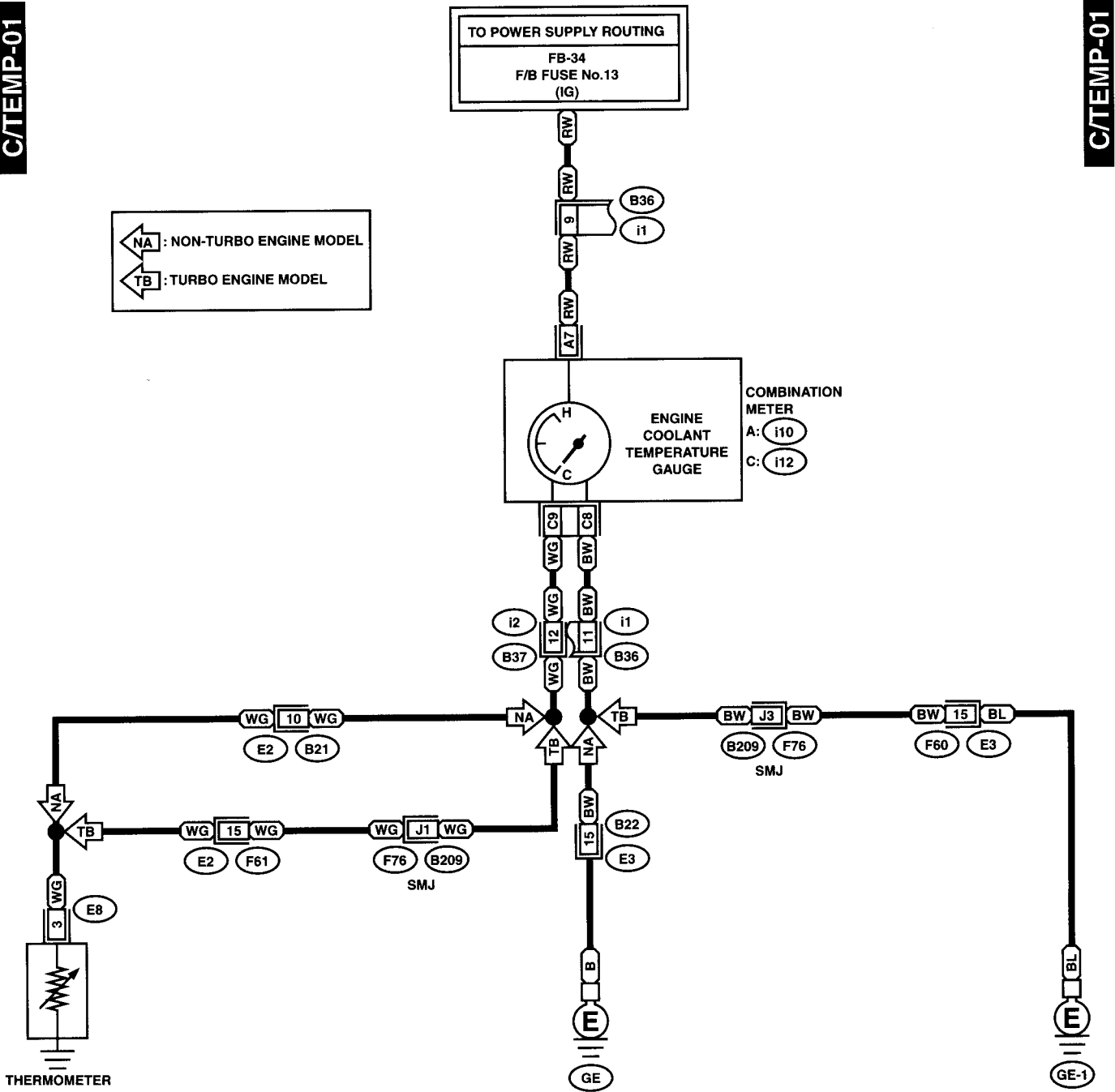

E8 (LIGHT GRAY)



A: i10 (GREEN)

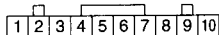

C: i12 (GREEN)



B22 (BROWN)



F60 (BROWN)

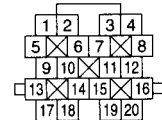

B21 (GRAY)

F61 (BLACK)

i1

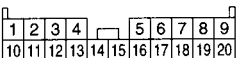

i2 (BROWN)

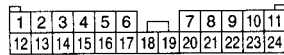

19.Engine Electrical System

A: SCHEMATIC

1. TURBO ENGINE MODEL

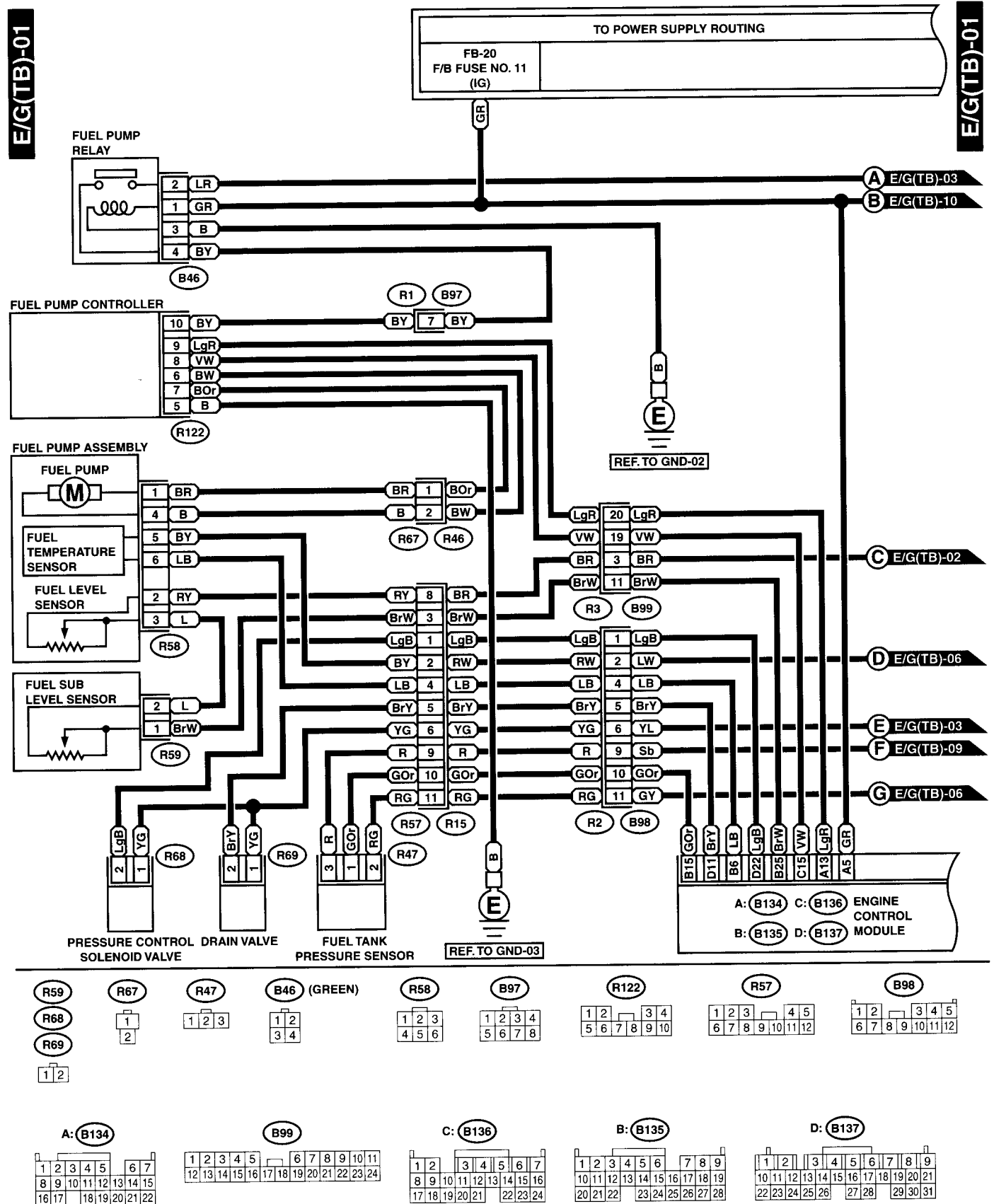

ENGINE ELECTRICAL SYSTEM

WIRING SYSTEM

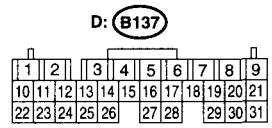
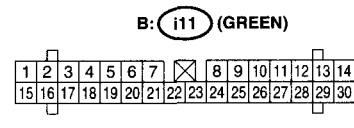
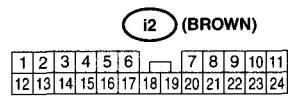
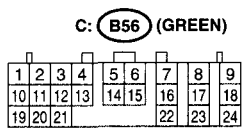
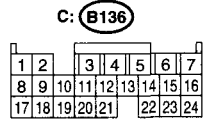
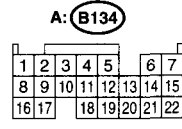
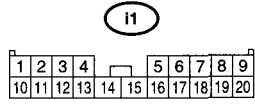
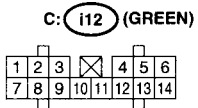
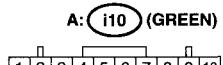
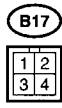
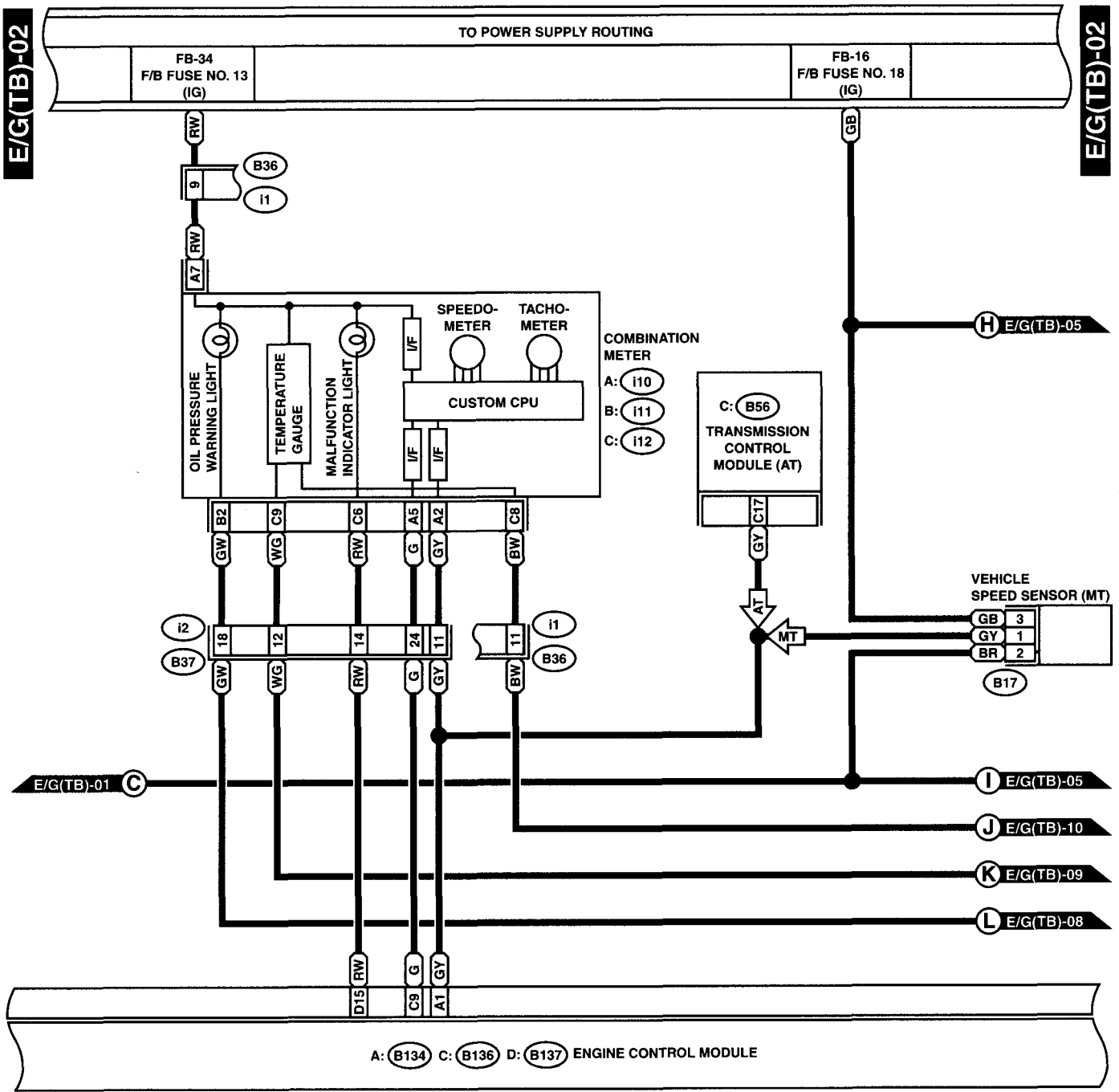

GU10-22B

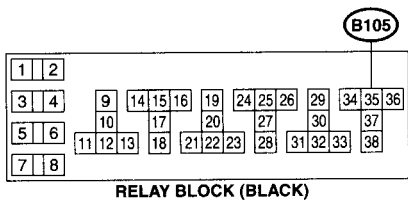
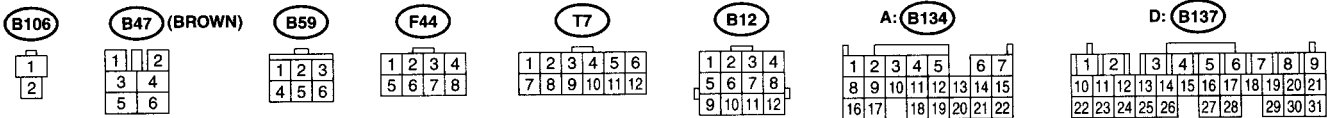
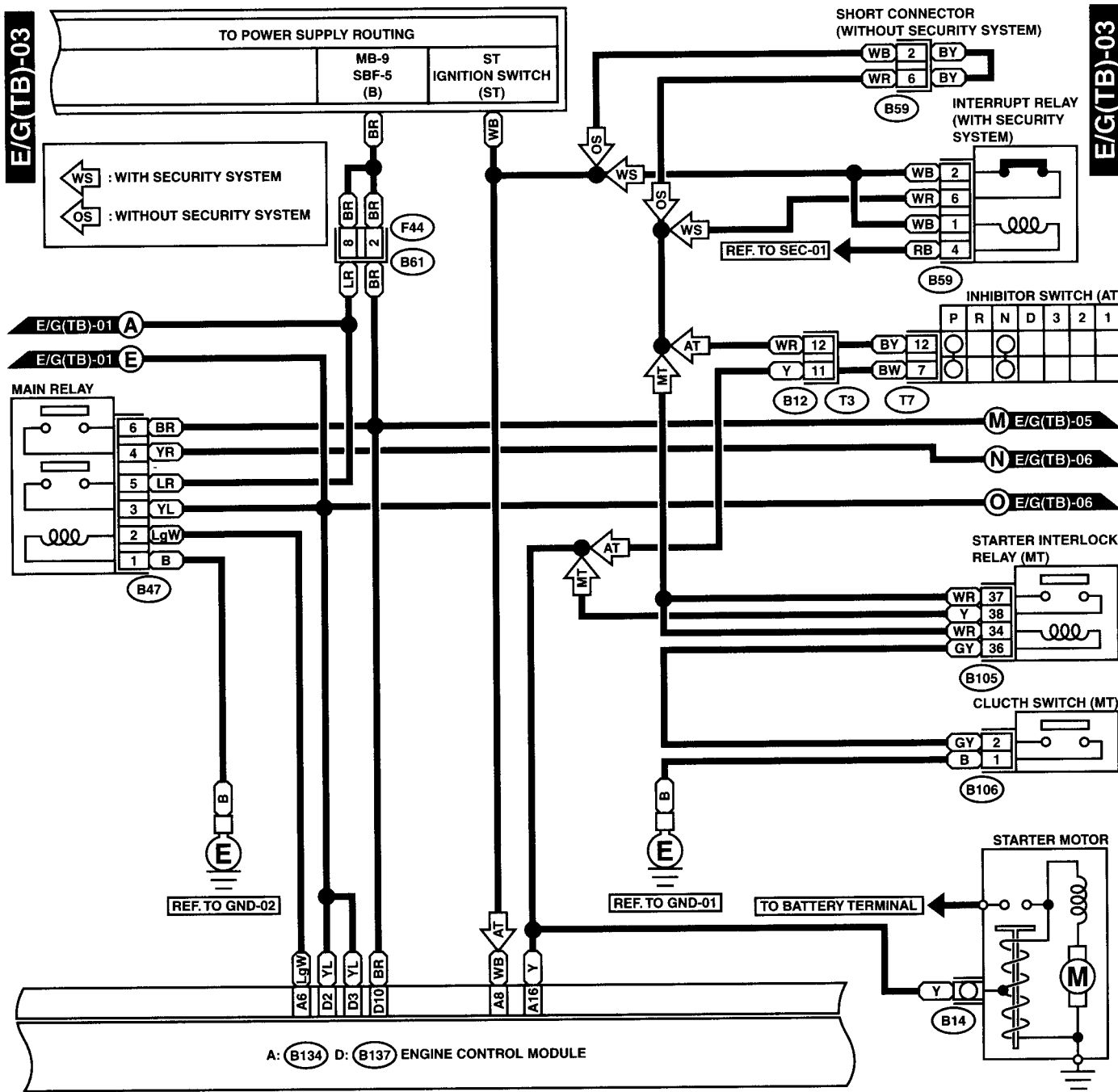

GU10-22C

ENGINE ELECTRICAL SYSTEM

WIRING SYSTEM

E/G(TB)-04

E/G(TB)-04

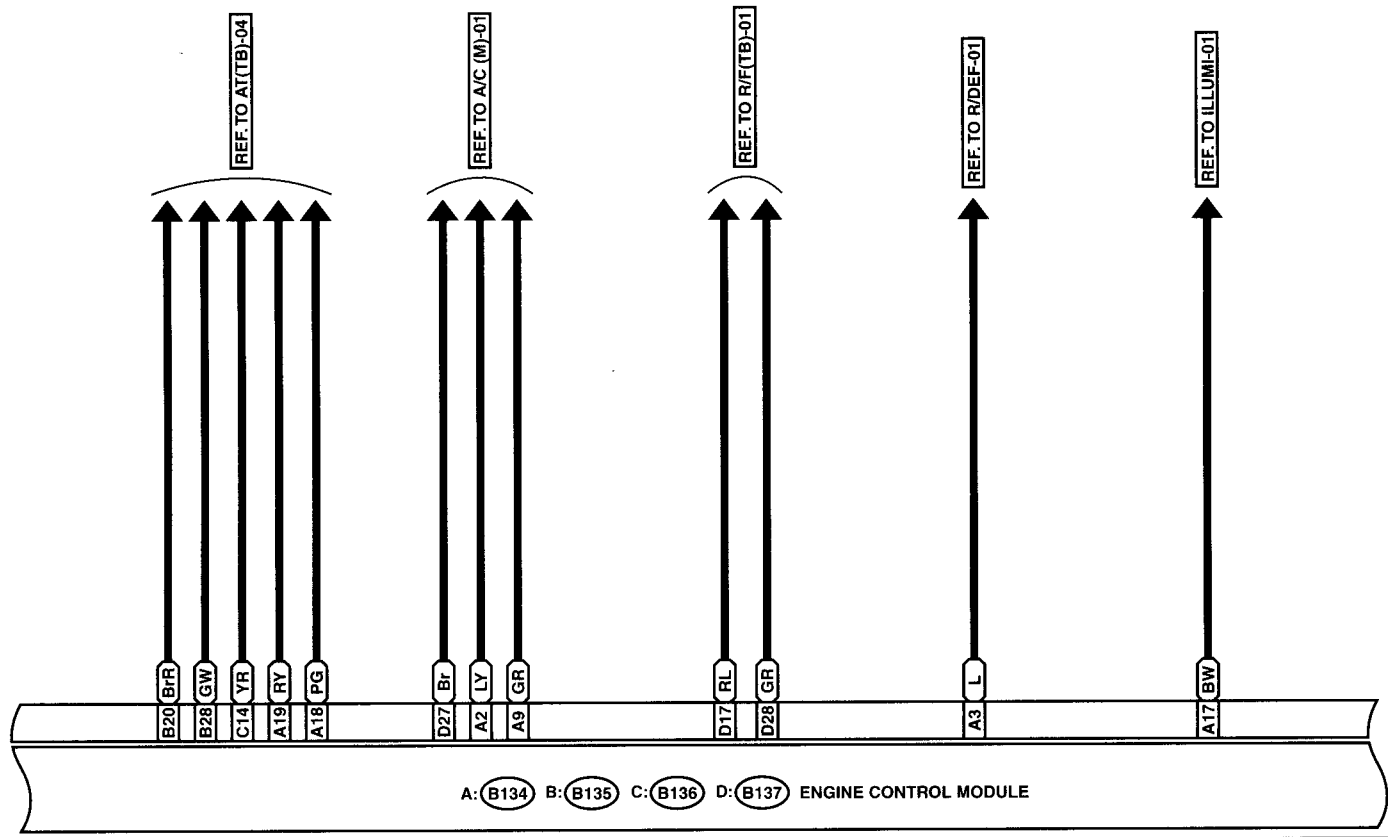

A: (B134)

1	2	3	4	5	6	7	
8	9	10	11	12	13	14	15
16	17	18	19	20	21	22	

C: (B136)

1	2	3	4	5	6	7		
8	9	10	11	12	13	14	15	16
17	18	19	20	21	22	23	24	

B: (B135)

1	2	3	4	5	6	7	8	9	
10	11	12	13	14	15	16	17	18	19
20	21	22	23	24	25	26	27	28	

D: (B137)

1	2	3	4	5	6	7	8	9			
10	11	12	13	14	15	16	17	18	19	20	21
22	23	24	25	26	27	28	29	30	31		

GU10-22D

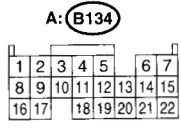
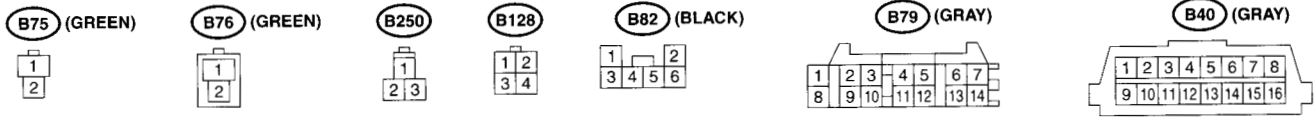
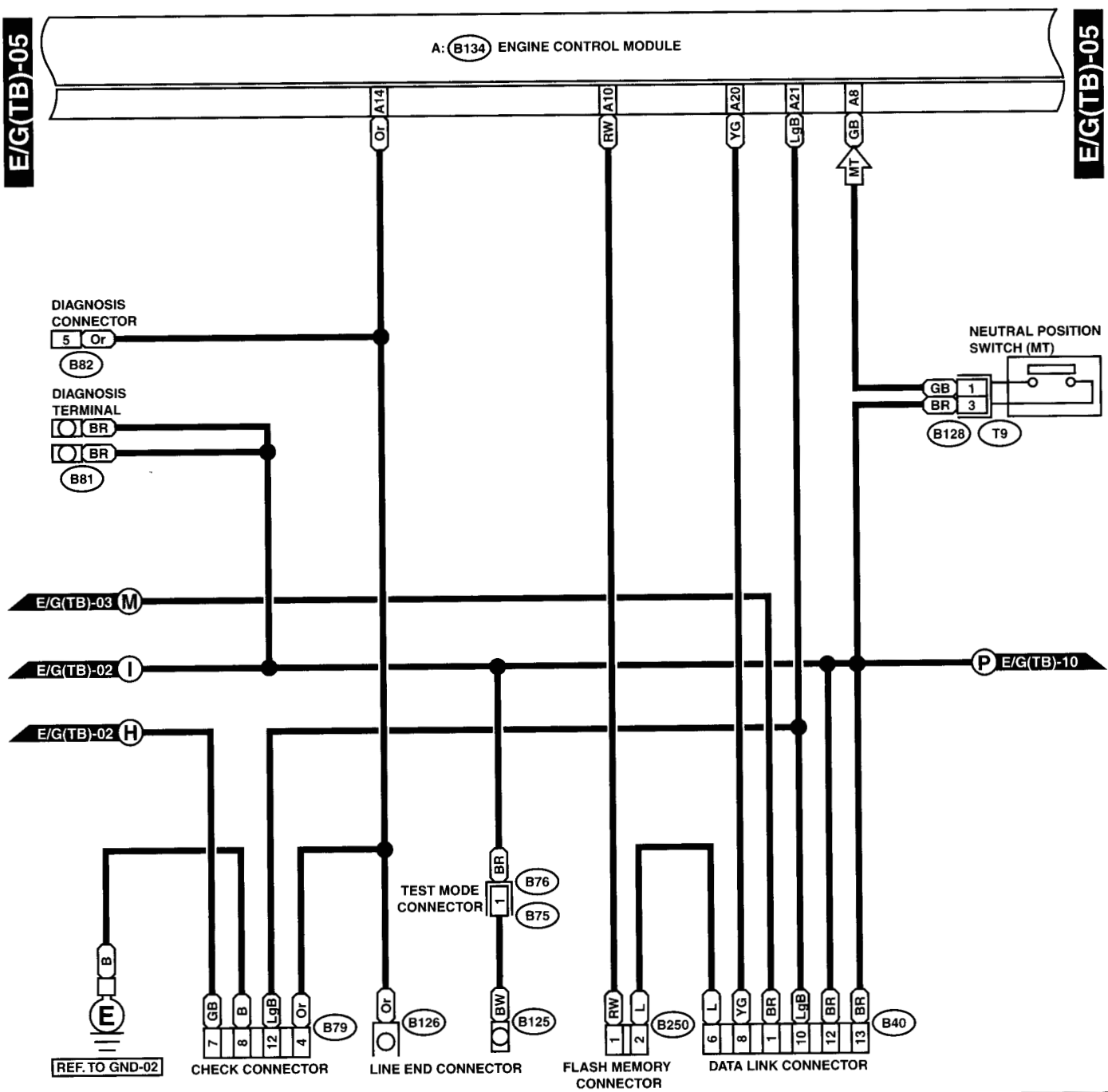

GU10-22E

ENGINE ELECTRICAL SYSTEM

WIRING SYSTEM

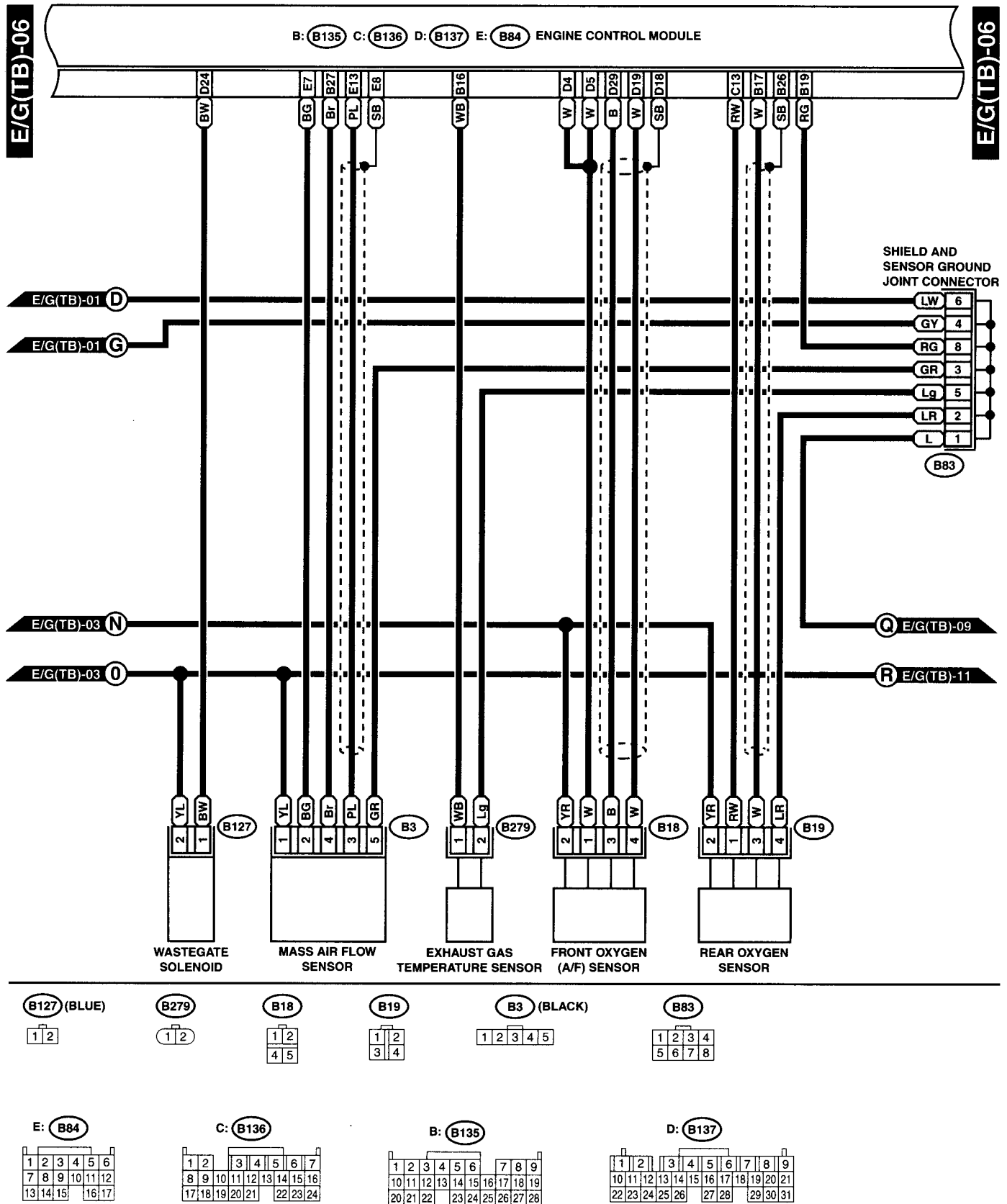

GU10-22F

E/G(TB)-07

E/G(TB)-07

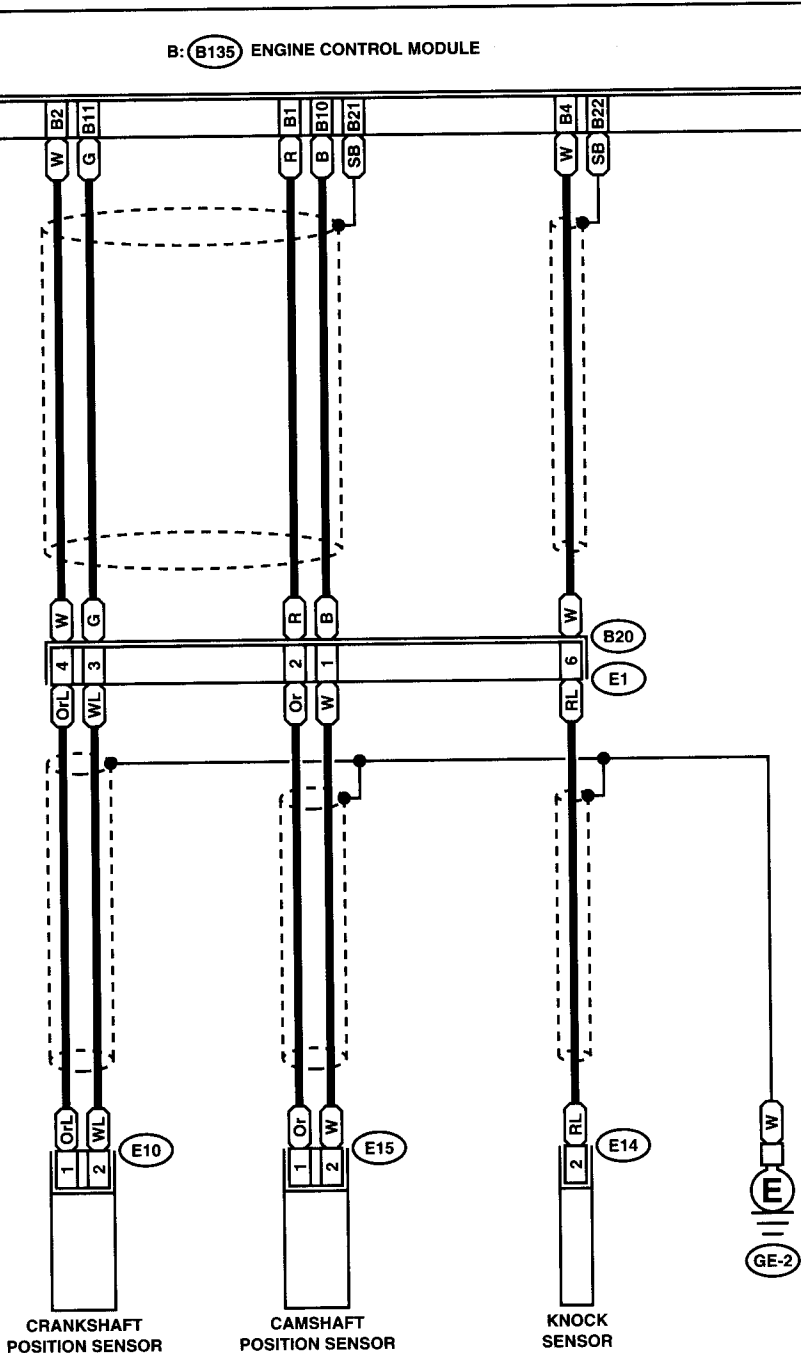

- E10 (LIGHT GRAY)**
- E14 (GRAY)**
- E15 (LIGHT GRAY)**

E1 (LIGHT GRAY)

1	2	3	4
5	6	7	
8	9	10	

B: B135

1	2	3	4	5	6	7	8	9	
10	11	12	13	14	15	16	17	18	19
20	21	22	23	24	25	26	27	28	

ENGINE ELECTRICAL SYSTEM

WIRING SYSTEM

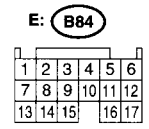
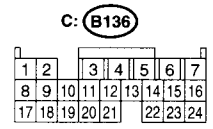
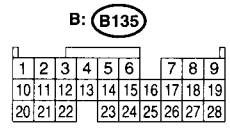
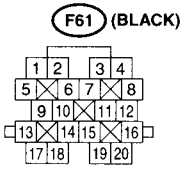
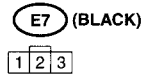
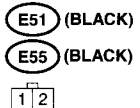
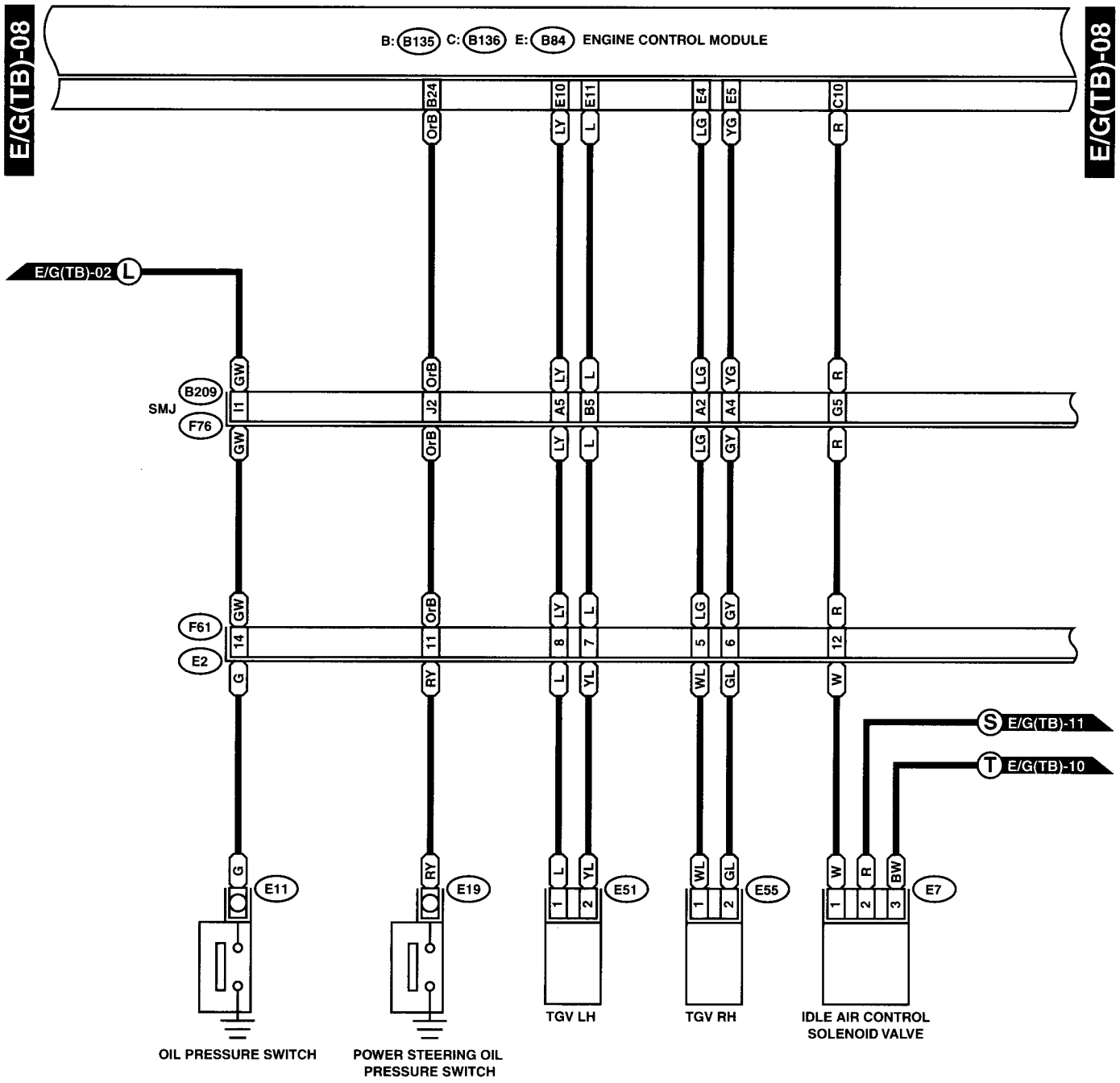

GU10-22H

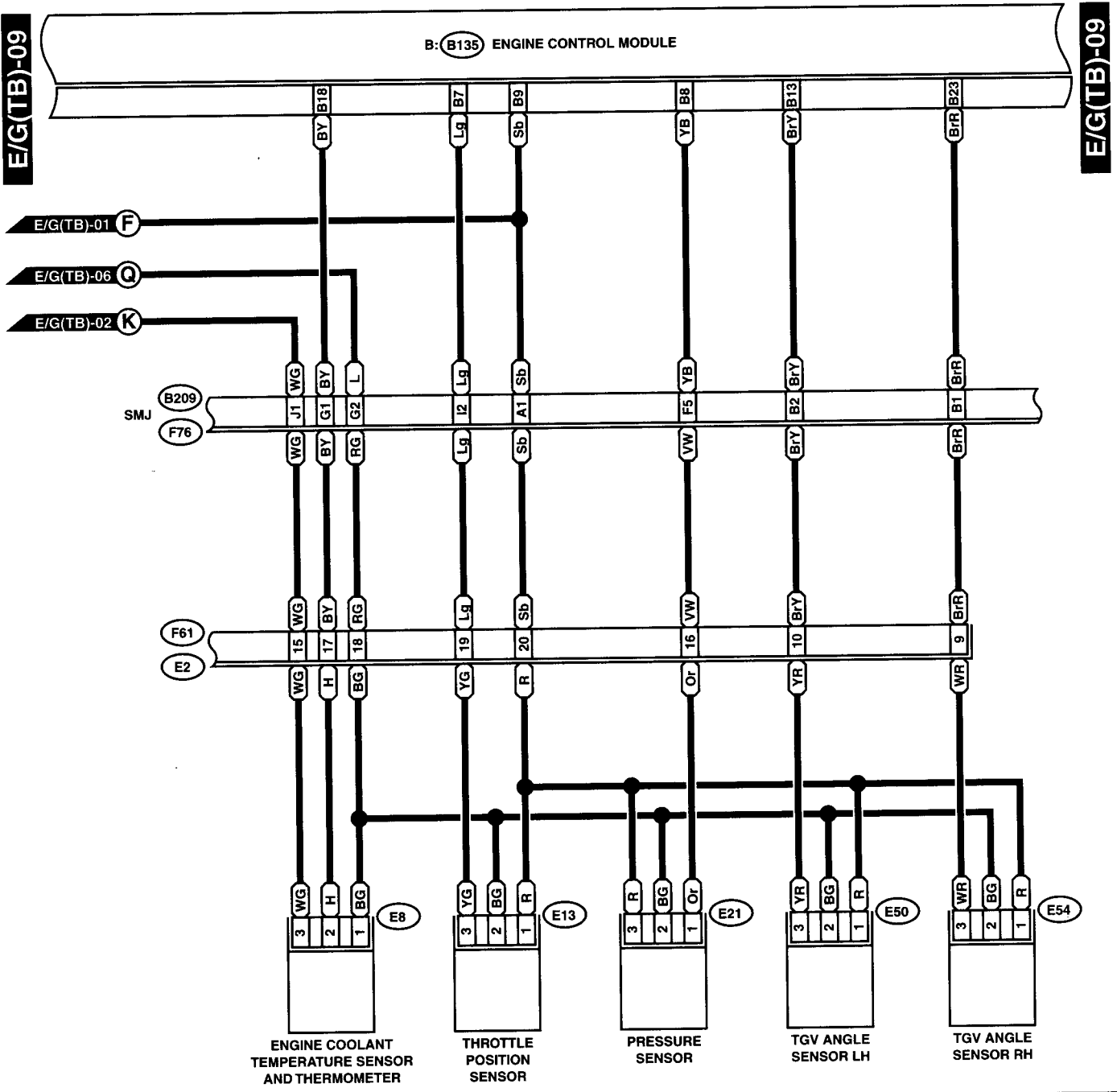

E8 (LIGHT GRAY)



E13 (BLACK)

E21 (BLACK)

E50 (BLACK)

E54 (BLACK)



F61 (BLACK)

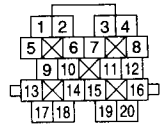

B: B135

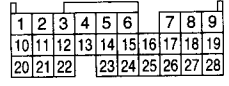

ENGINE ELECTRICAL SYSTEM

WIRING SYSTEM

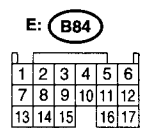
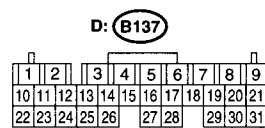
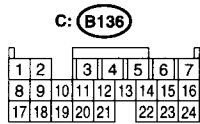
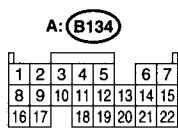
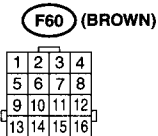
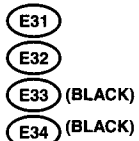
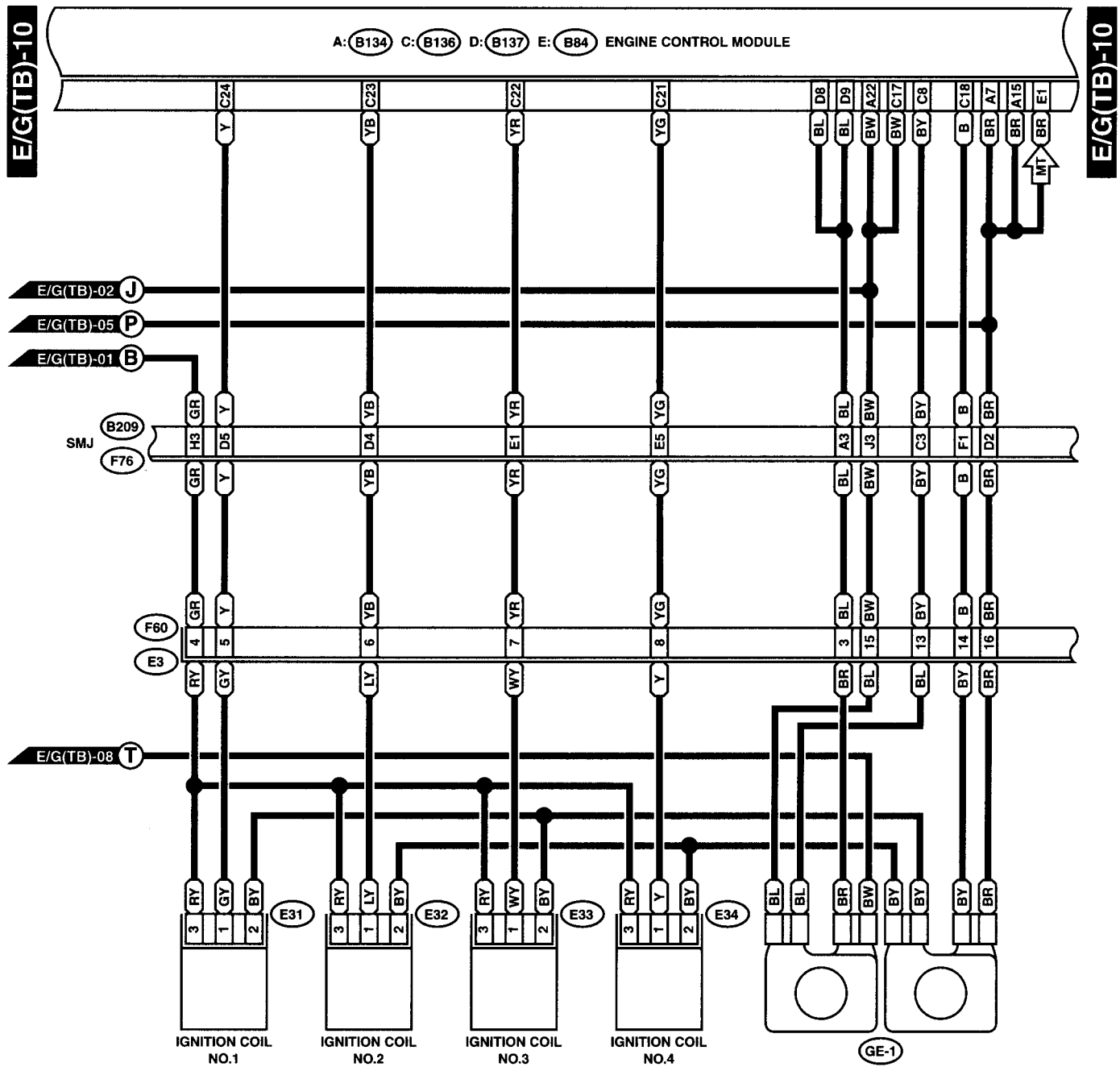

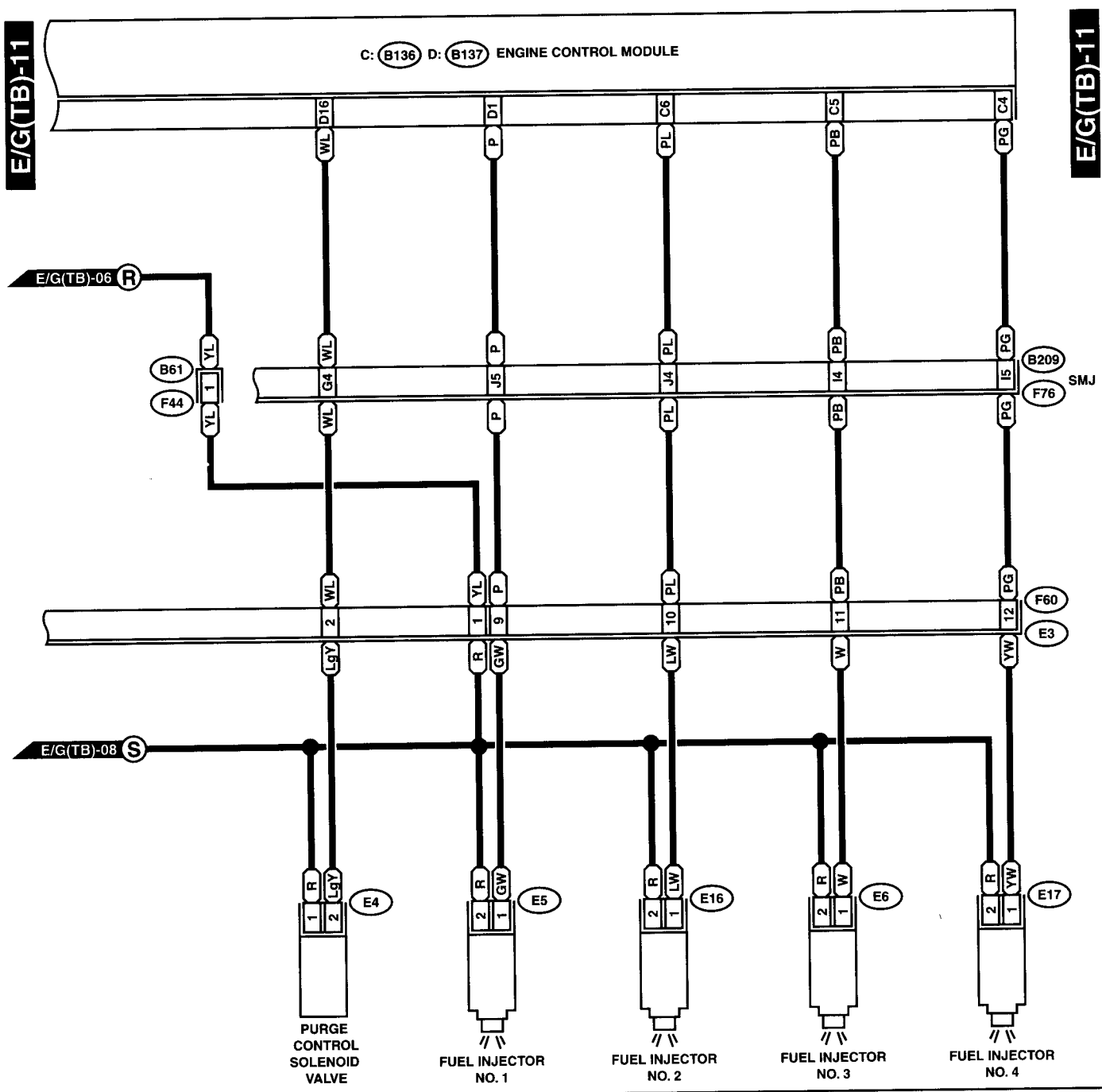

E5 (DARK GRAY)	E4 (BLACK)	F60 (BROWN)	F44	C: B136	D: B137																																																																																																			
<table border="1"><tr><td>1</td><td>2</td></tr></table>	1	2	<table border="1"><tr><td>1</td><td>2</td></tr></table>	1	2	<table border="1"><tr><td>1</td><td>2</td><td>3</td><td>4</td></tr><tr><td>5</td><td>6</td><td>7</td><td>8</td></tr><tr><td>9</td><td>10</td><td>11</td><td>12</td></tr><tr><td>13</td><td>14</td><td>15</td><td>16</td></tr></table>	1	2	3	4	5	6	7	8	9	10	11	12	13	14	15	16	<table border="1"><tr><td>1</td><td>2</td><td>3</td><td>4</td></tr><tr><td>5</td><td>6</td><td>7</td><td>8</td></tr></table>	1	2	3	4	5	6	7	8	<table border="1"><tr><td>1</td><td>2</td><td>3</td><td>4</td><td>5</td><td>6</td><td>7</td></tr><tr><td>8</td><td>9</td><td>10</td><td>11</td><td>12</td><td>13</td><td>14</td></tr><tr><td>15</td><td>16</td><td>17</td><td>18</td><td>19</td><td>20</td><td>21</td></tr><tr><td>22</td><td>23</td><td>24</td><td>25</td><td>26</td><td>27</td><td>28</td></tr><tr><td>29</td><td>30</td><td>31</td><td>32</td><td>33</td><td>34</td><td>35</td></tr></table>	1	2	3	4	5	6	7	8	9	10	11	12	13	14	15	16	17	18	19	20	21	22	23	24	25	26	27	28	29	30	31	32	33	34	35	<table border="1"><tr><td>1</td><td>2</td><td>3</td><td>4</td><td>5</td><td>6</td><td>7</td><td>8</td><td>9</td></tr><tr><td>10</td><td>11</td><td>12</td><td>13</td><td>14</td><td>15</td><td>16</td><td>17</td><td>18</td></tr><tr><td>19</td><td>20</td><td>21</td><td>22</td><td>23</td><td>24</td><td>25</td><td>26</td><td>27</td></tr><tr><td>28</td><td>29</td><td>30</td><td>31</td><td>32</td><td>33</td><td>34</td><td>35</td><td>36</td></tr></table>	1	2	3	4	5	6	7	8	9	10	11	12	13	14	15	16	17	18	19	20	21	22	23	24	25	26	27	28	29	30	31	32	33	34	35	36
1	2																																																																																																							
1	2																																																																																																							
1	2	3	4																																																																																																					
5	6	7	8																																																																																																					
9	10	11	12																																																																																																					
13	14	15	16																																																																																																					
1	2	3	4																																																																																																					
5	6	7	8																																																																																																					
1	2	3	4	5	6	7																																																																																																		
8	9	10	11	12	13	14																																																																																																		
15	16	17	18	19	20	21																																																																																																		
22	23	24	25	26	27	28																																																																																																		
29	30	31	32	33	34	35																																																																																																		
1	2	3	4	5	6	7	8	9																																																																																																
10	11	12	13	14	15	16	17	18																																																																																																
19	20	21	22	23	24	25	26	27																																																																																																
28	29	30	31	32	33	34	35	36																																																																																																
<table border="1"><tr><td>1</td><td>2</td></tr></table>	1	2																																																																																																						
1	2																																																																																																							

ENGINE ELECTRICAL SYSTEM

WIRING SYSTEM

2. NON-TURBO ENGINE MODEL

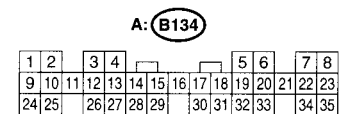
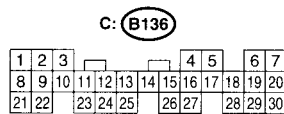
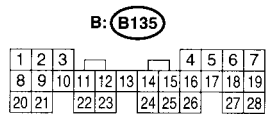
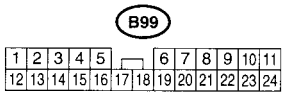
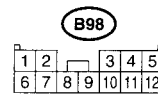
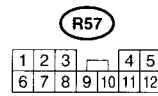
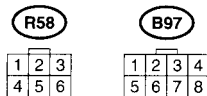
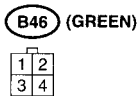
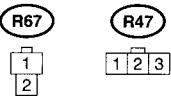
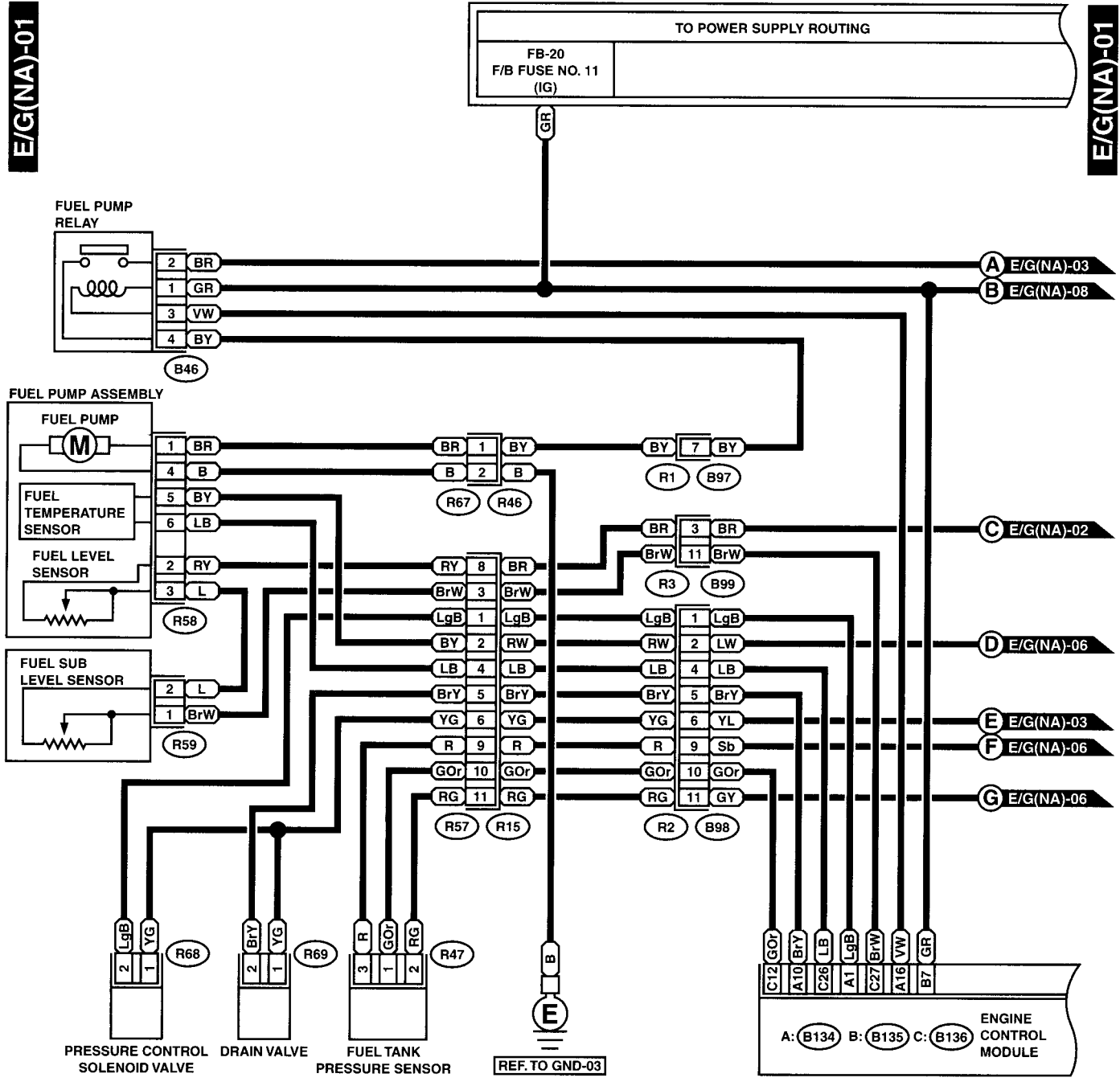

ENGINE ELECTRICAL SYSTEM

WIRING SYSTEM

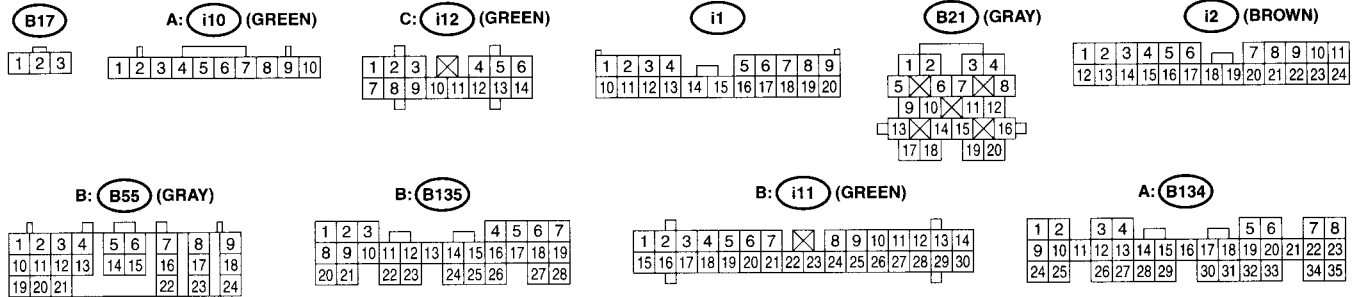
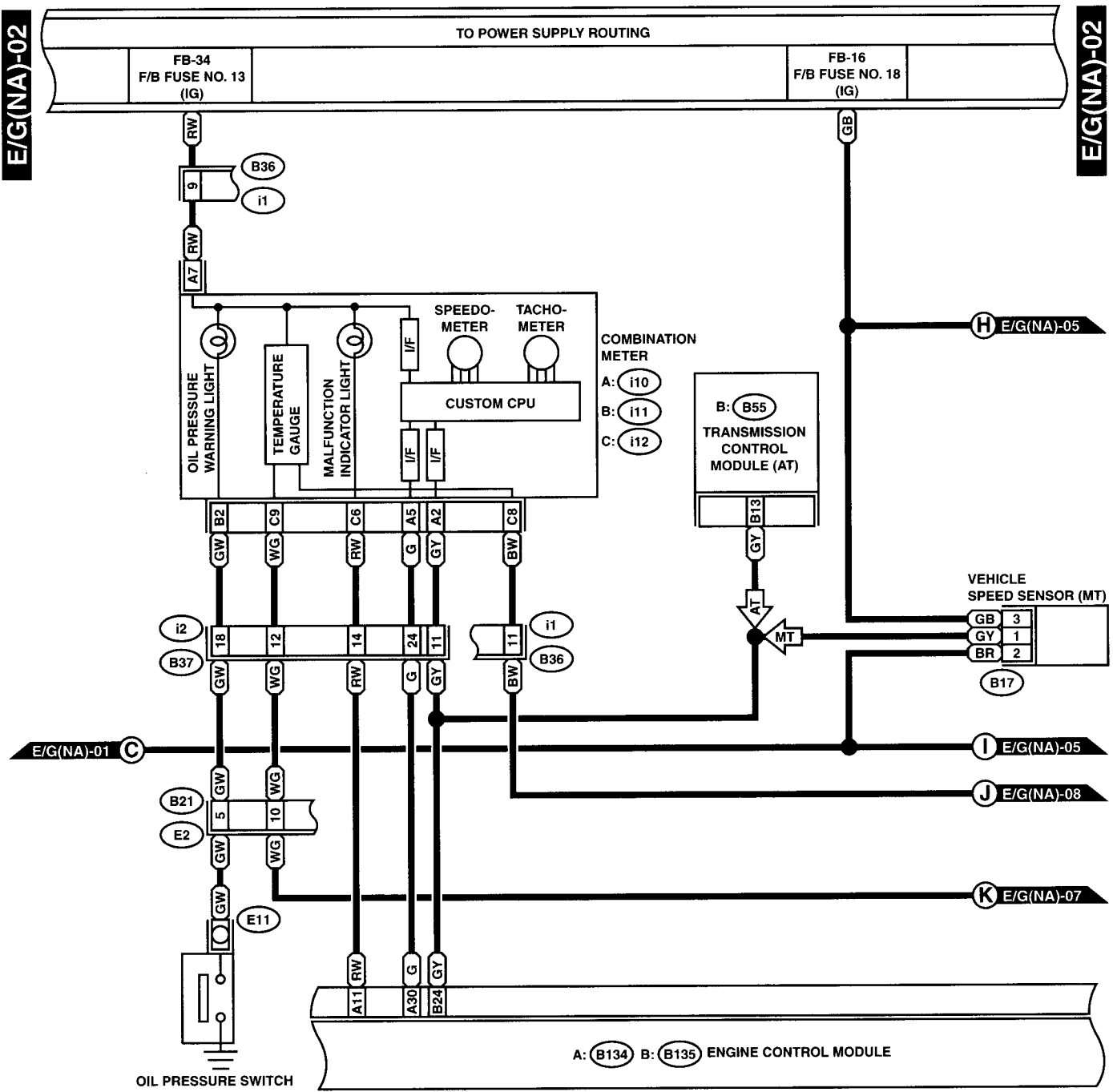

GU10-23B

ENGINE ELECTRICAL SYSTEM

WIRING SYSTEM

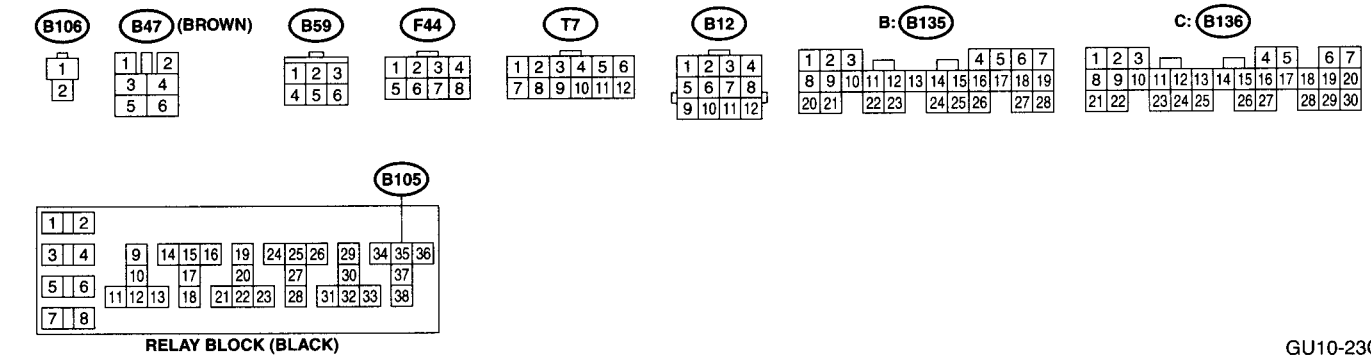
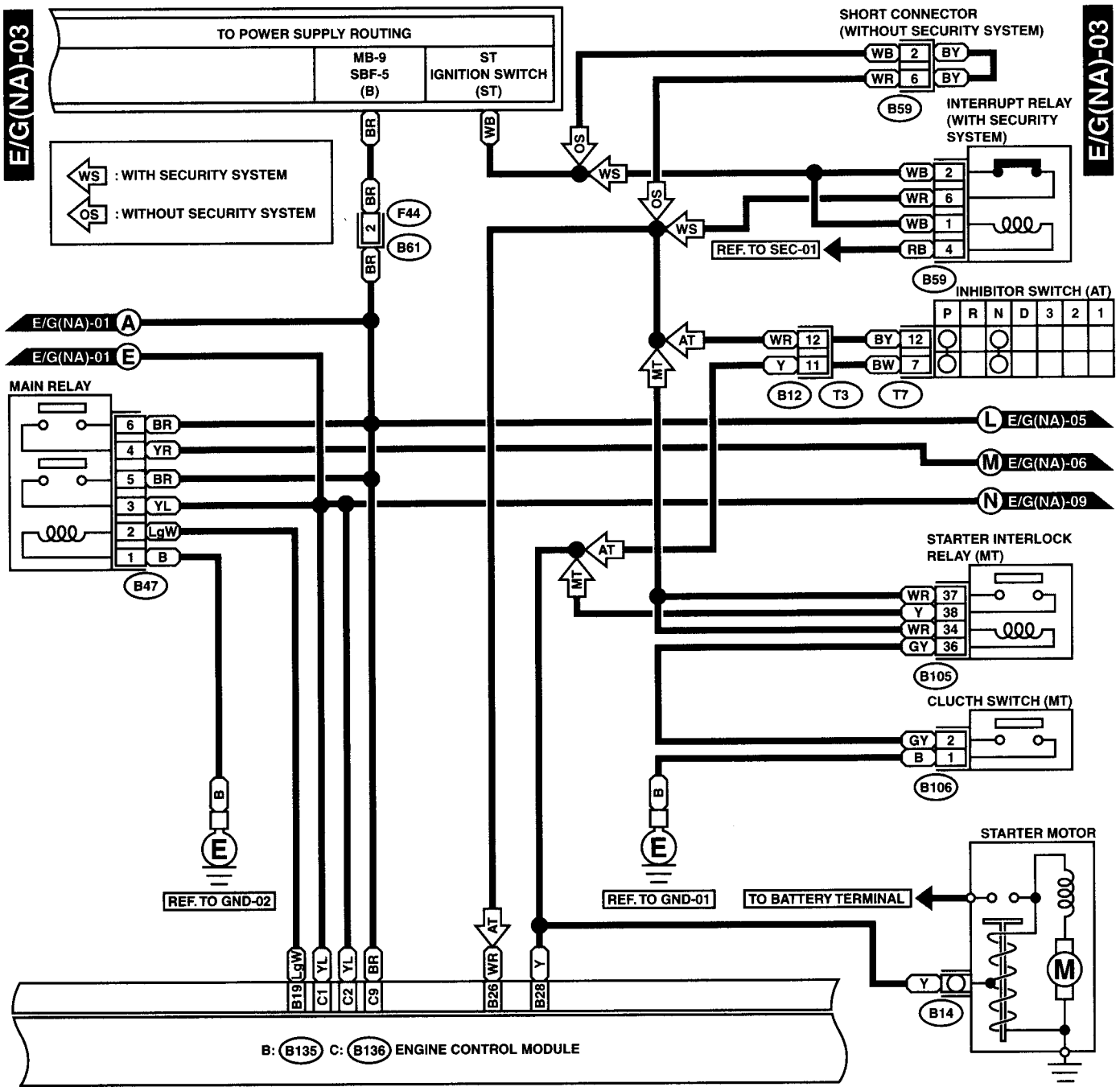

GU10-23C

E/G(NA)-04

E/G(NA)-04

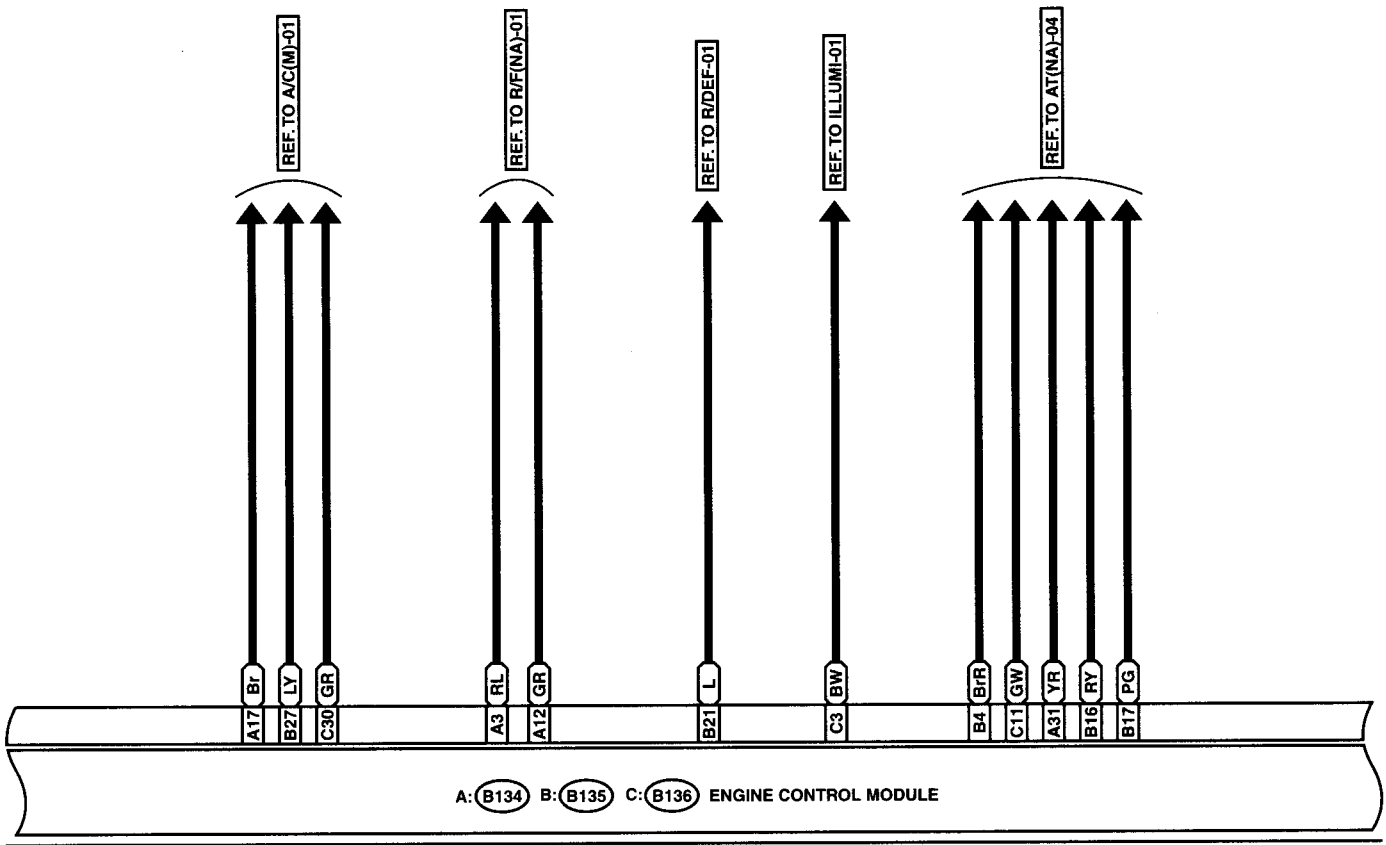

B: (B135)

1	2	3		4	5	6	7				
8	9	10	11	12	13	14	15	16	17	18	19
20	21	22	23	24	25	26	27	28			

C: (B136)

1	2	3		4	5	6	7					
8	9	10	11	12	13	14	15	16	17	18	19	20
21	22	23	24	25	26	27	28	29	30			

A: (B134)

1	2	3	4		5	6	7	8						
9	10	11	12	13	14	15	16	17	18	19	20	21	22	23
24	25	26	27	28	29	30	31	32	33	34	35			

ENGINE ELECTRICAL SYSTEM

WIRING SYSTEM

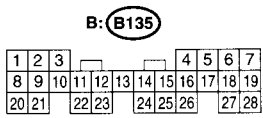
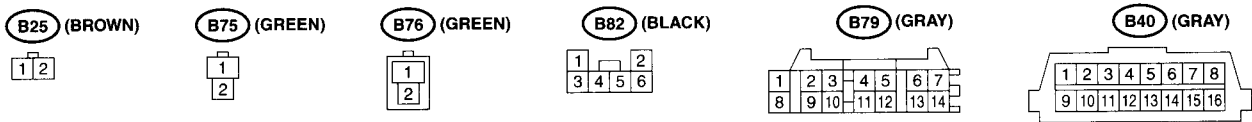
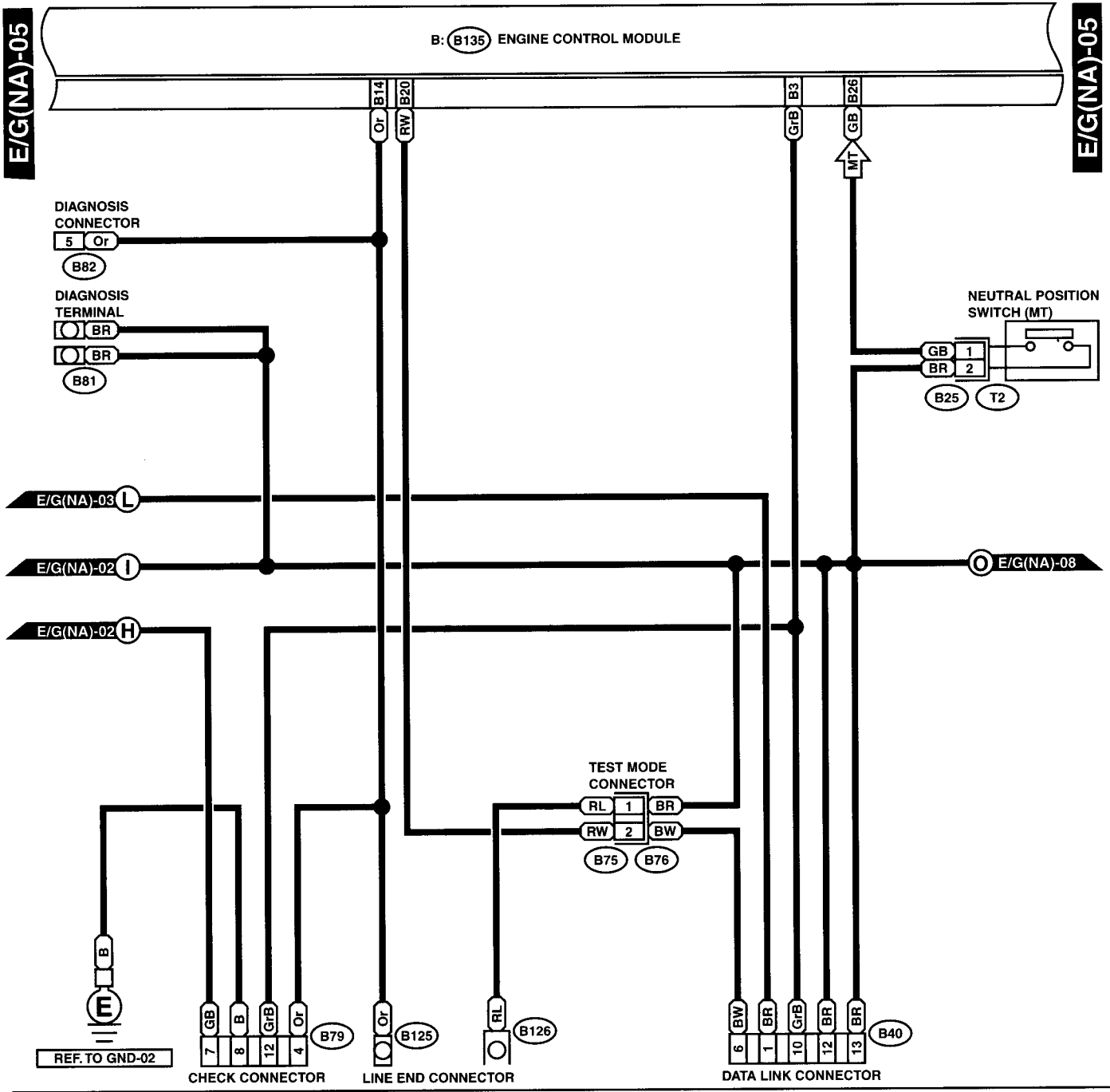

GU10-23E

ENGINE ELECTRICAL SYSTEM

WIRING SYSTEM

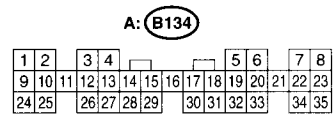
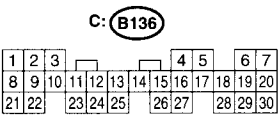
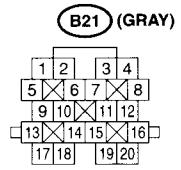
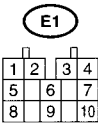
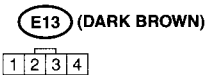
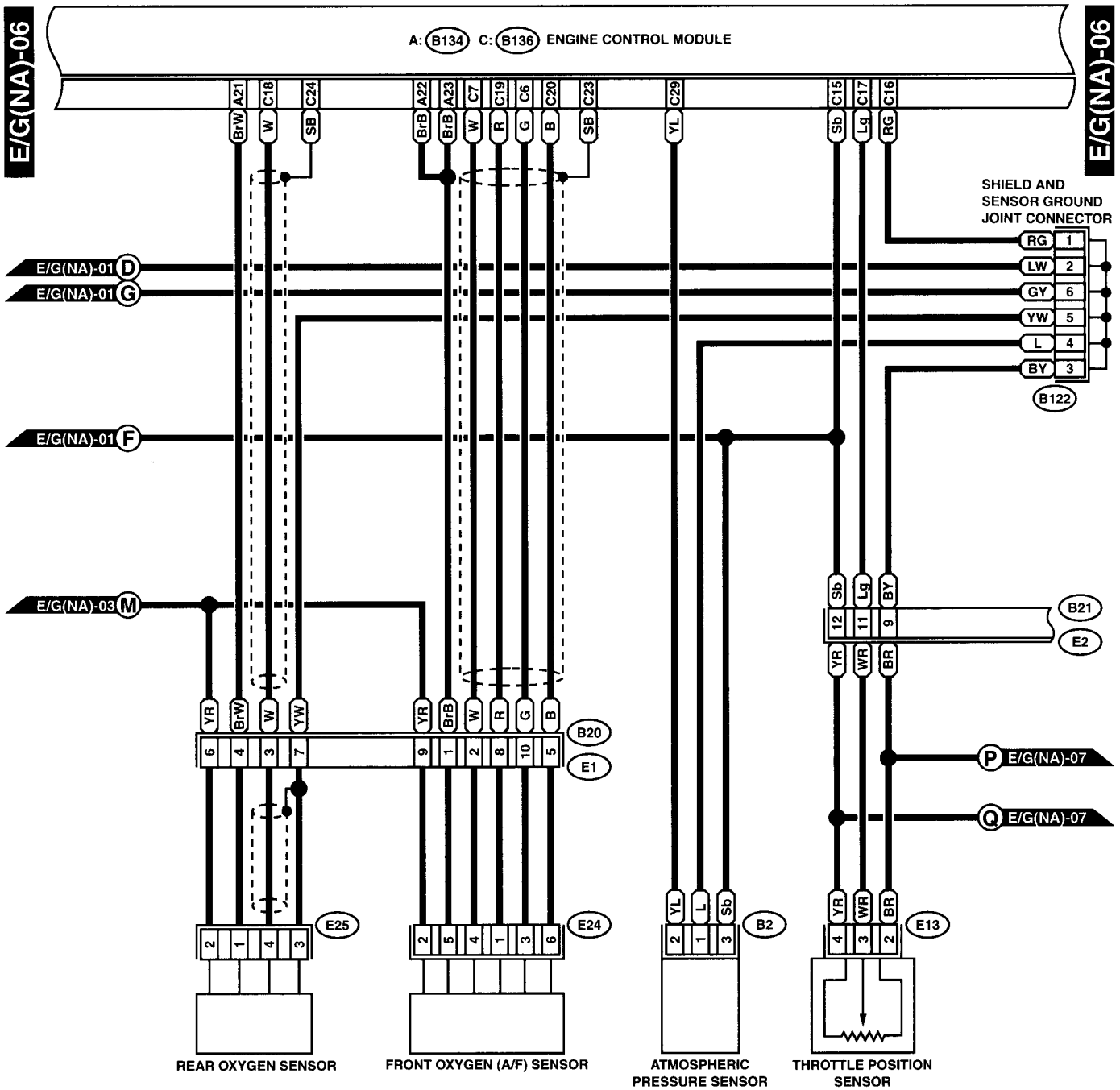

GU10-23F

ENGINE ELECTRICAL SYSTEM

WIRING SYSTEM

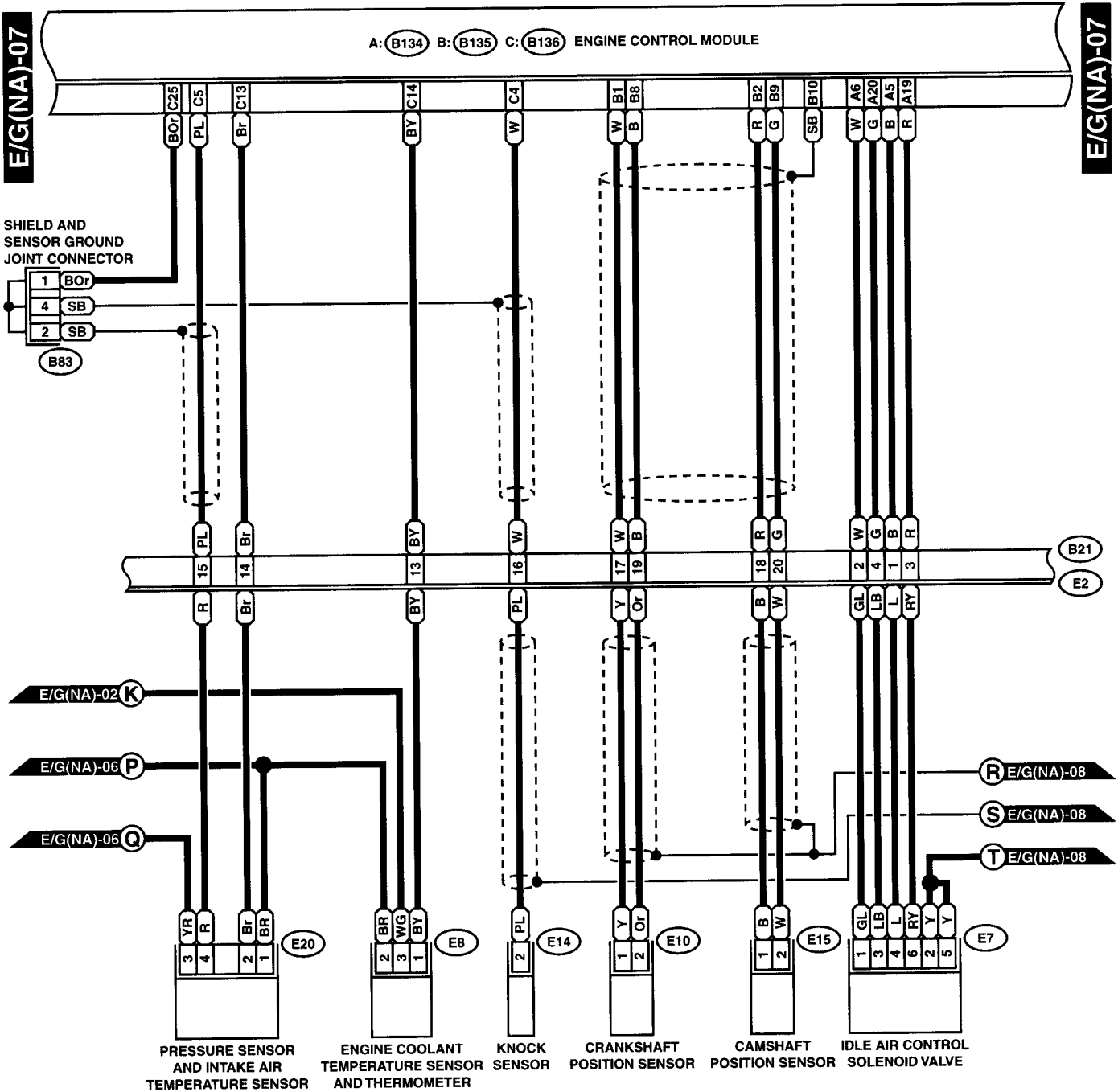

(E14)

(E10) (LIGHT GRAY)

(E15) (BLACK)

1 2

(E8) (LIGHT GRAY)

1 2
3

(E20) (BLACK)

1 2 3 4

(E7) (BLACK)

1 2 3
4 5 6

(B83)

1 2 3
4 5 6

(B21) (GRAY)

1	2	3	4
5	6	7	8
9	10	11	12
13	14	15	16
17	18	19	20

B: (B135)

1	2	3	4	5	6	7
8	9	10	11	12	13	14
15	16	17	18	19	20	21
22	23	24	25	26	27	28

C: (B136)

1	2	3	4	5	6	7
8	9	10	11	12	13	14
15	16	17	18	19	20	21
22	23	24	25	26	27	28
29	30	31	32	33	34	35

A: (B134)

1	2	3	4	5	6	7	8
9	10	11	12	13	14	15	16
17	18	19	20	21	22	23	24
25	26	27	28	29	30	31	32
33	34	35	36	37	38	39	40

ENGINE ELECTRICAL SYSTEM

WIRING SYSTEM

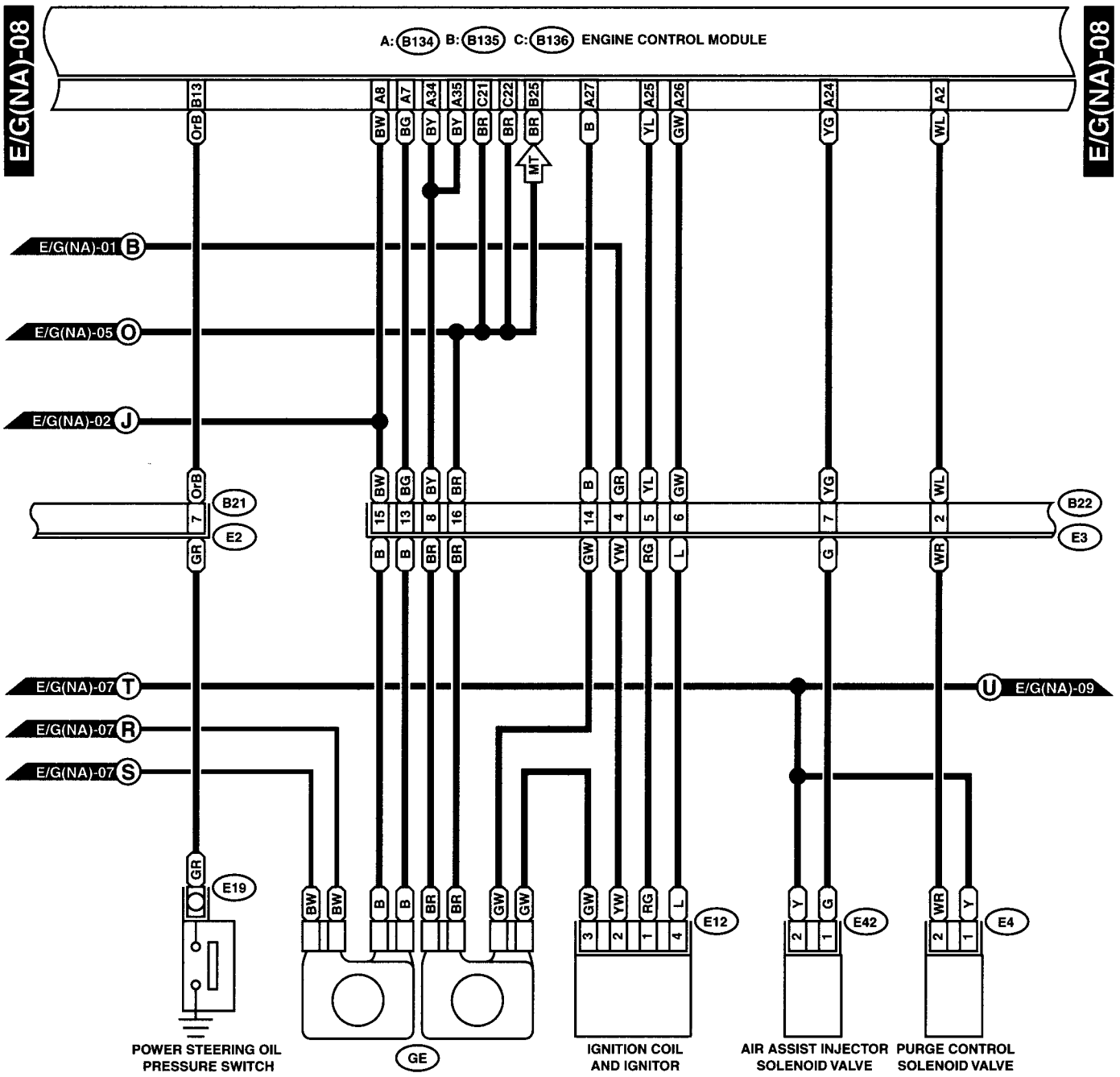

E4 (BLACK)

E12 (DARK GRAY)

B22 (BROWN)

B21 (GRAY)

B: B135

E42 (PURPLE)

1	2	3	4
---	---	---	---

1	2	3	4
5	6	7	8
9	10	11	12
13	14	15	16

1	2	3	4
5	6	7	8
9	10	11	12
13	14	15	16
17	18	19	20

1	2	3	4	5	6	7					
8	9	10	11	12	13	14	15	16	17	18	19
20	21	22	23	24	25	26	27	28			

C: B136

1	2	3	4	5	6	7						
8	9	10	11	12	13	14	15	16	17	18	19	20
21	22	23	24	25	26	27	28	29	30			

A: B134

1	2	3	4	5	6	7	8							
9	10	11	12	13	14	15	16	17	18	19	20	21	22	23
24	25	26	27	28	29	30	31	32	33	34	35			

GU10-23H

ENGINE ELECTRICAL SYSTEM

WIRING SYSTEM

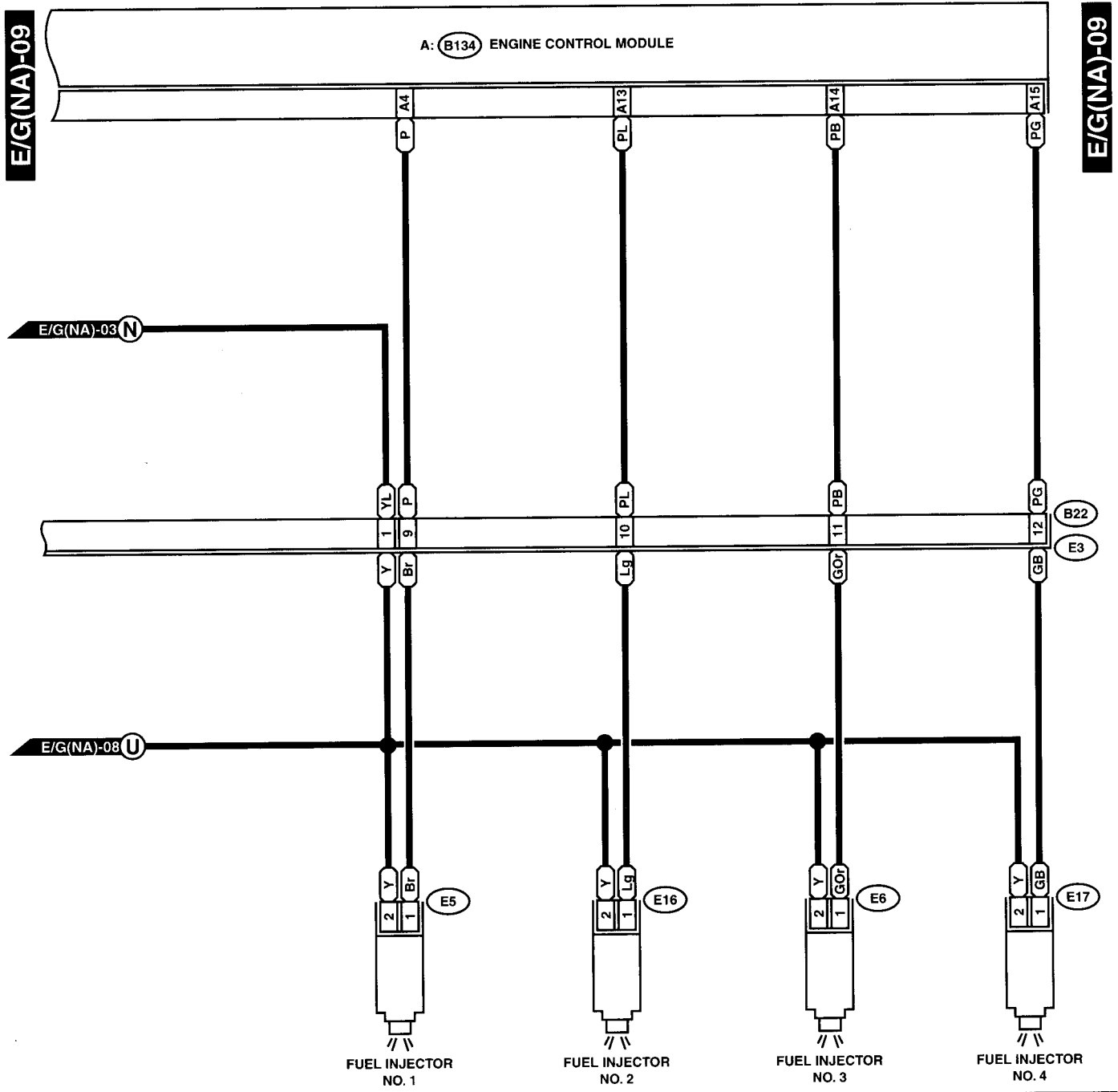

E5 (LIGHT GRAY)

E6 (LIGHT GRAY)

E16 (LIGHT GRAY)

E17 (LIGHT GRAY)



B22 (BROWN)

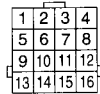

A: B134

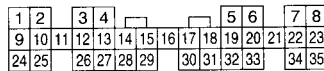

GU10-23I

20. Fuel Gauge System

A: SCHEMATIC

FUEL/G-01

FUEL/G-01

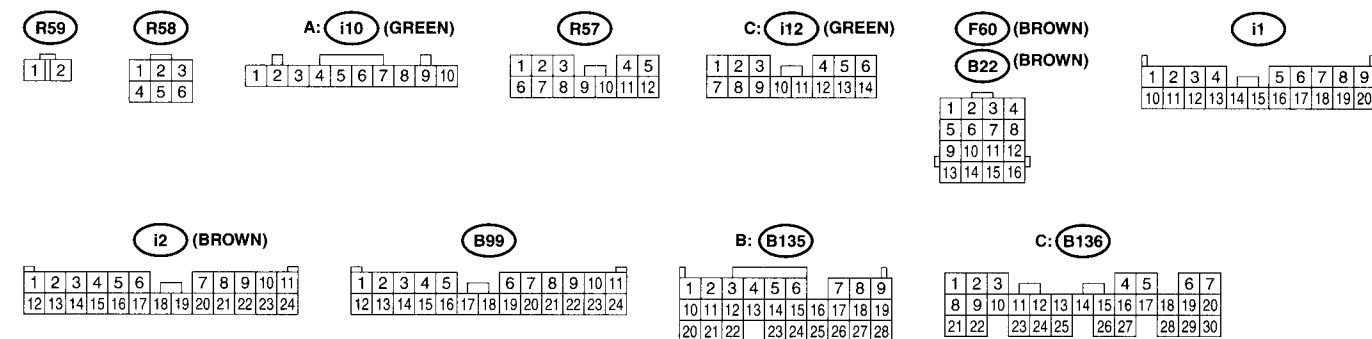
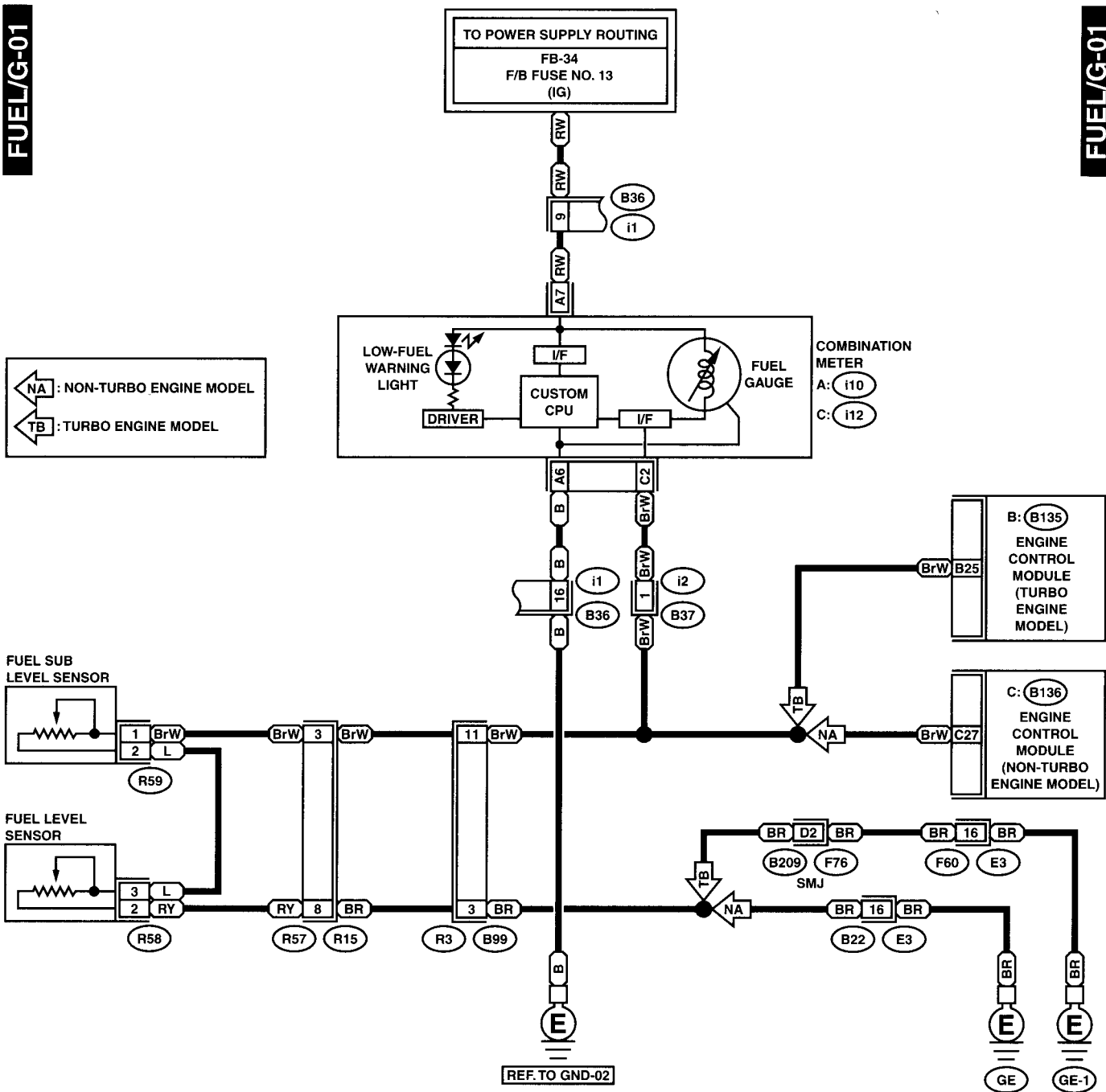

FRONT ACCESSORY POWER SUPPLY SYSTEM

WIRING SYSTEM

21. Front Accessory Power Supply System

A: SCHEMATIC

FAPS-01

FAPS-01

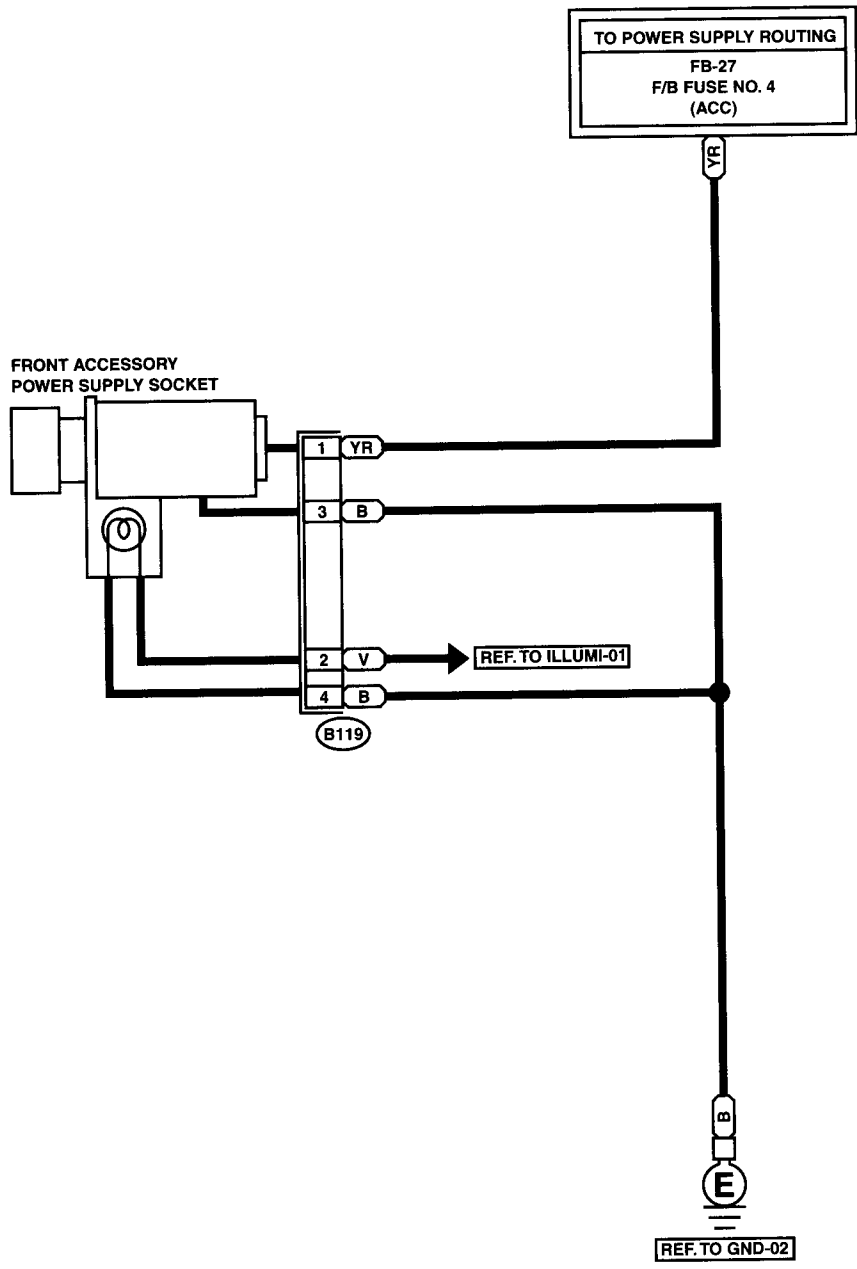

22.Horn System

A: SCHEMATIC

HORN-01

HORN-01

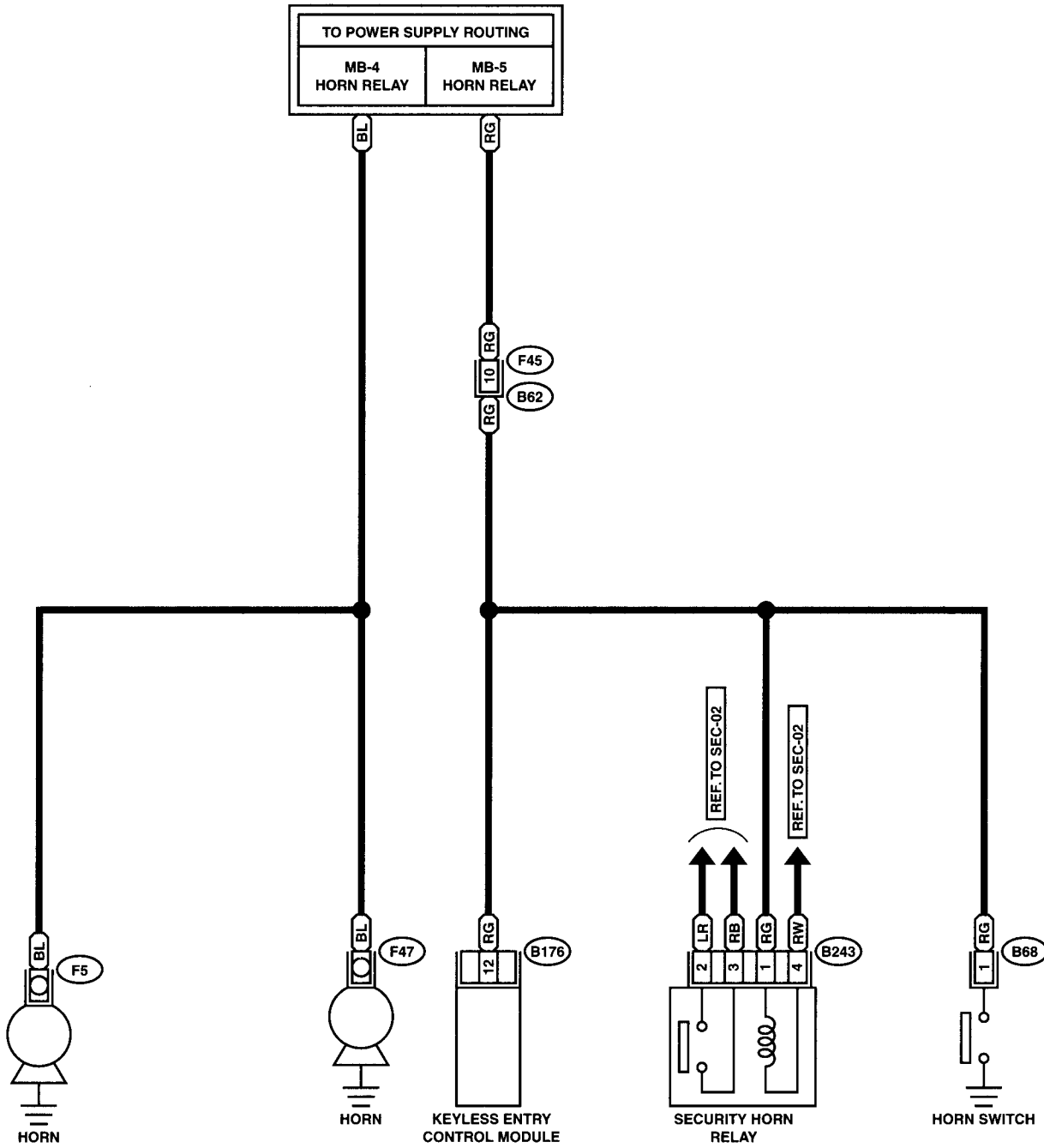

(B68) (BLACK)



(B243)



(B176)

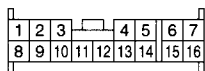

(F45)

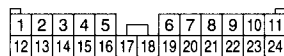

KEYLESS ENTRY SYSTEM

WIRING SYSTEM

23. Keyless Entry System

A: SCHEMATIC

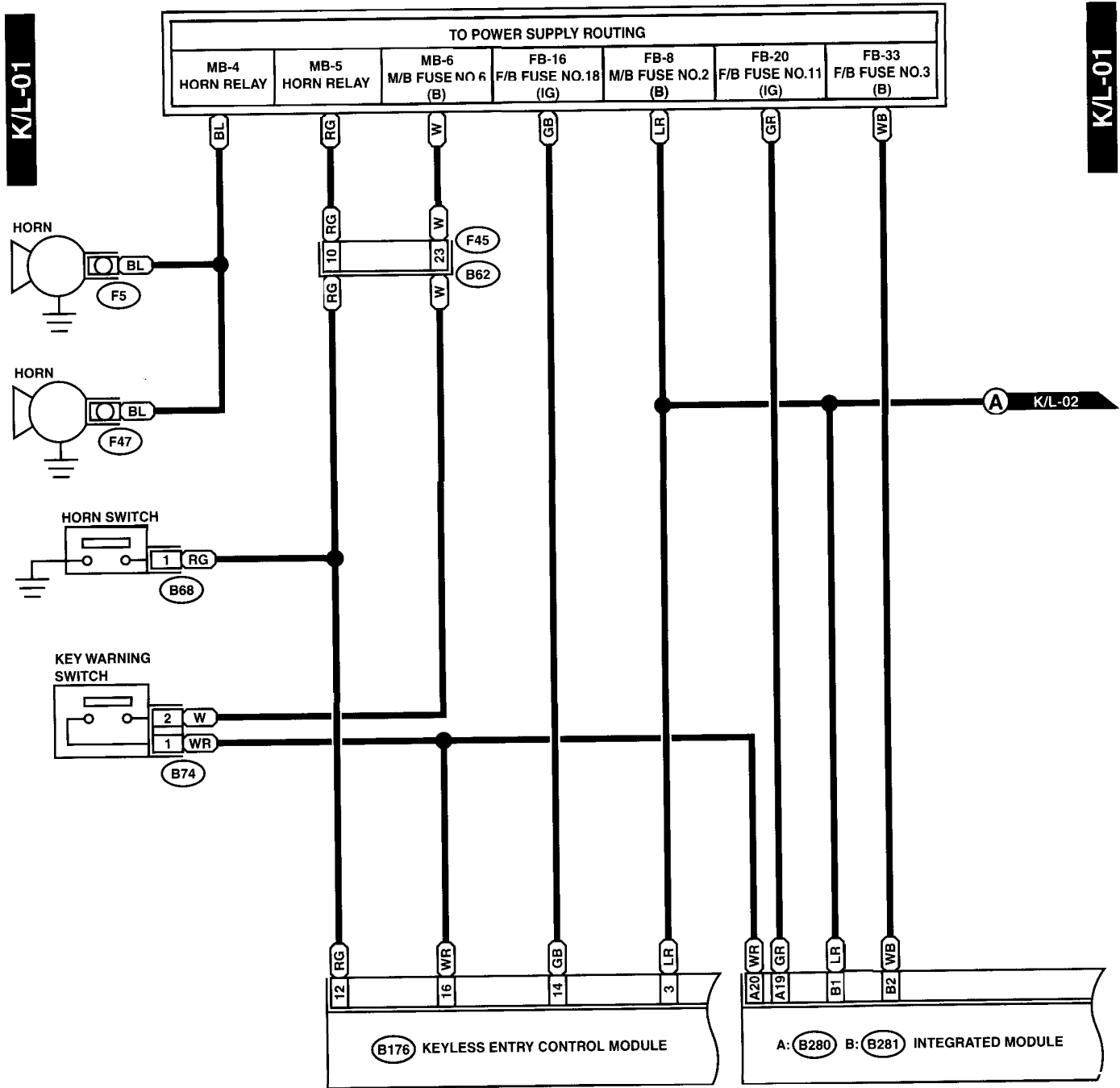

K/L-01

K/L-01

A K/L-02

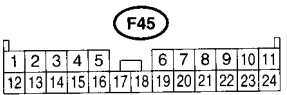
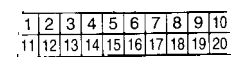
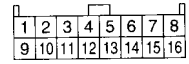
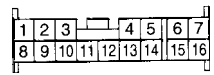

KEYLESS ENTRY SYSTEM

WIRING SYSTEM

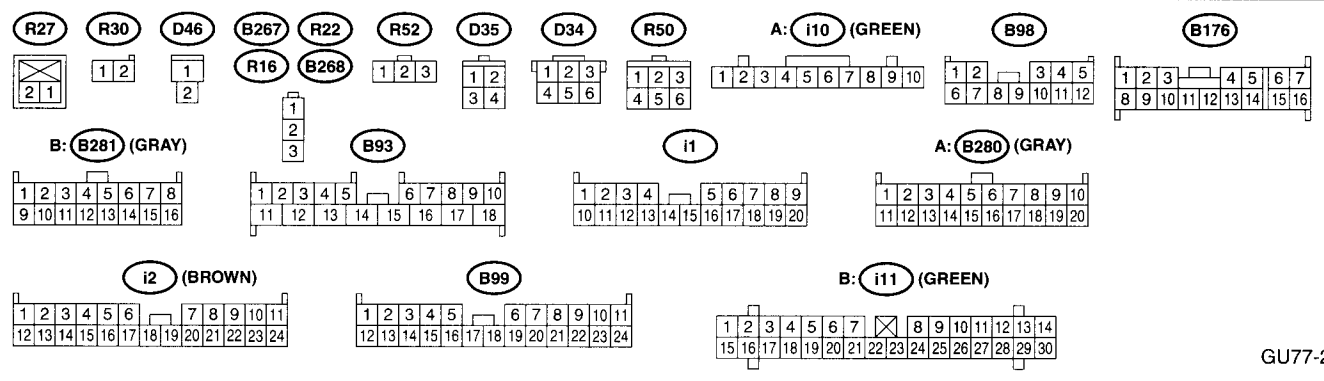
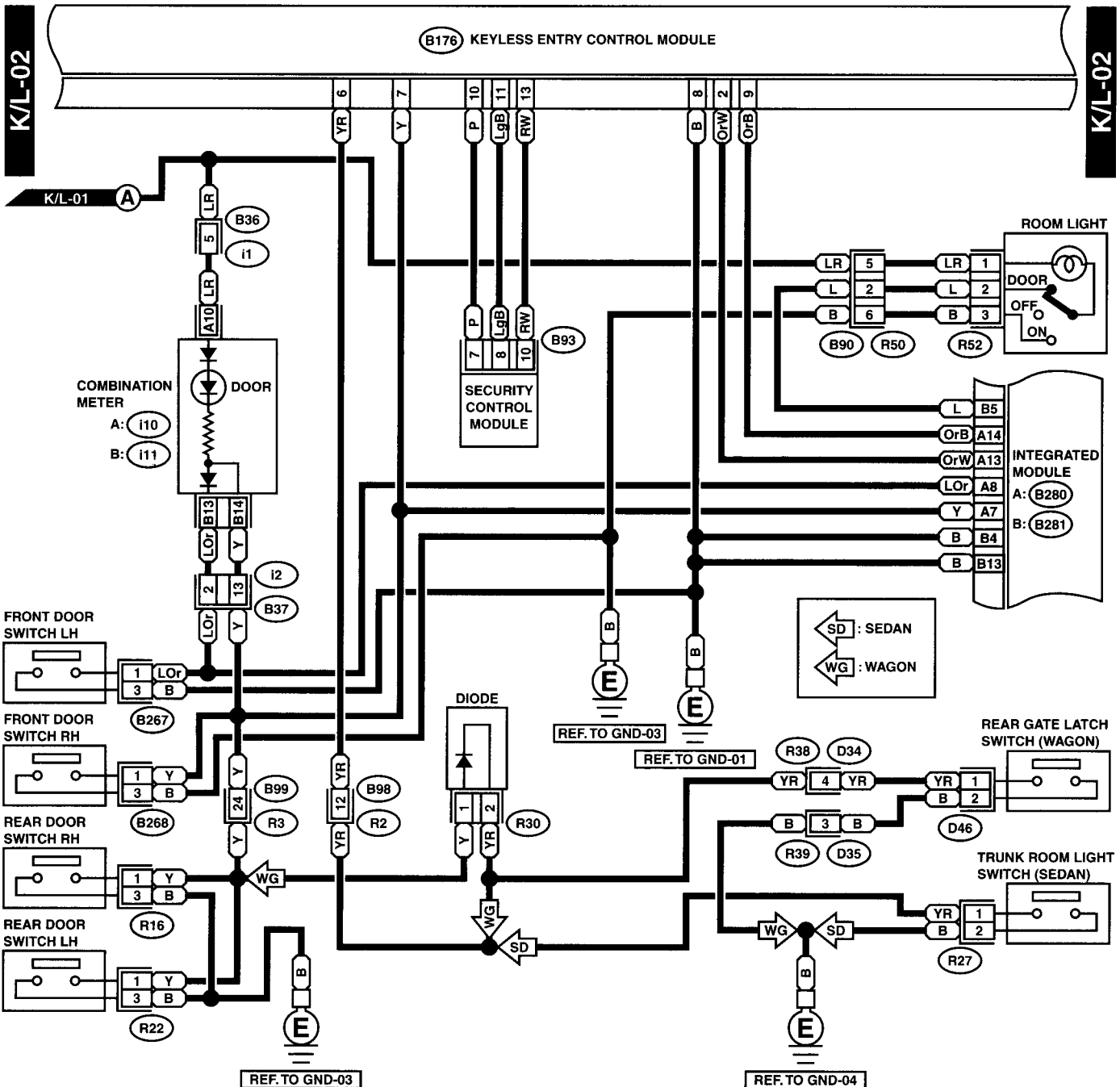

GU77-20B

KEYLESS ENTRY SYSTEM

WIRING SYSTEM

K/L-03

K/L-03

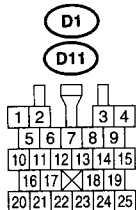
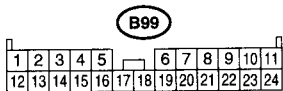
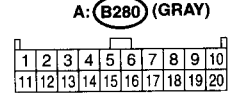
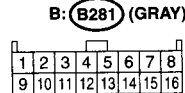
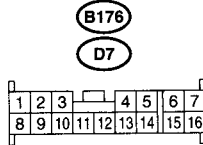
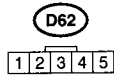
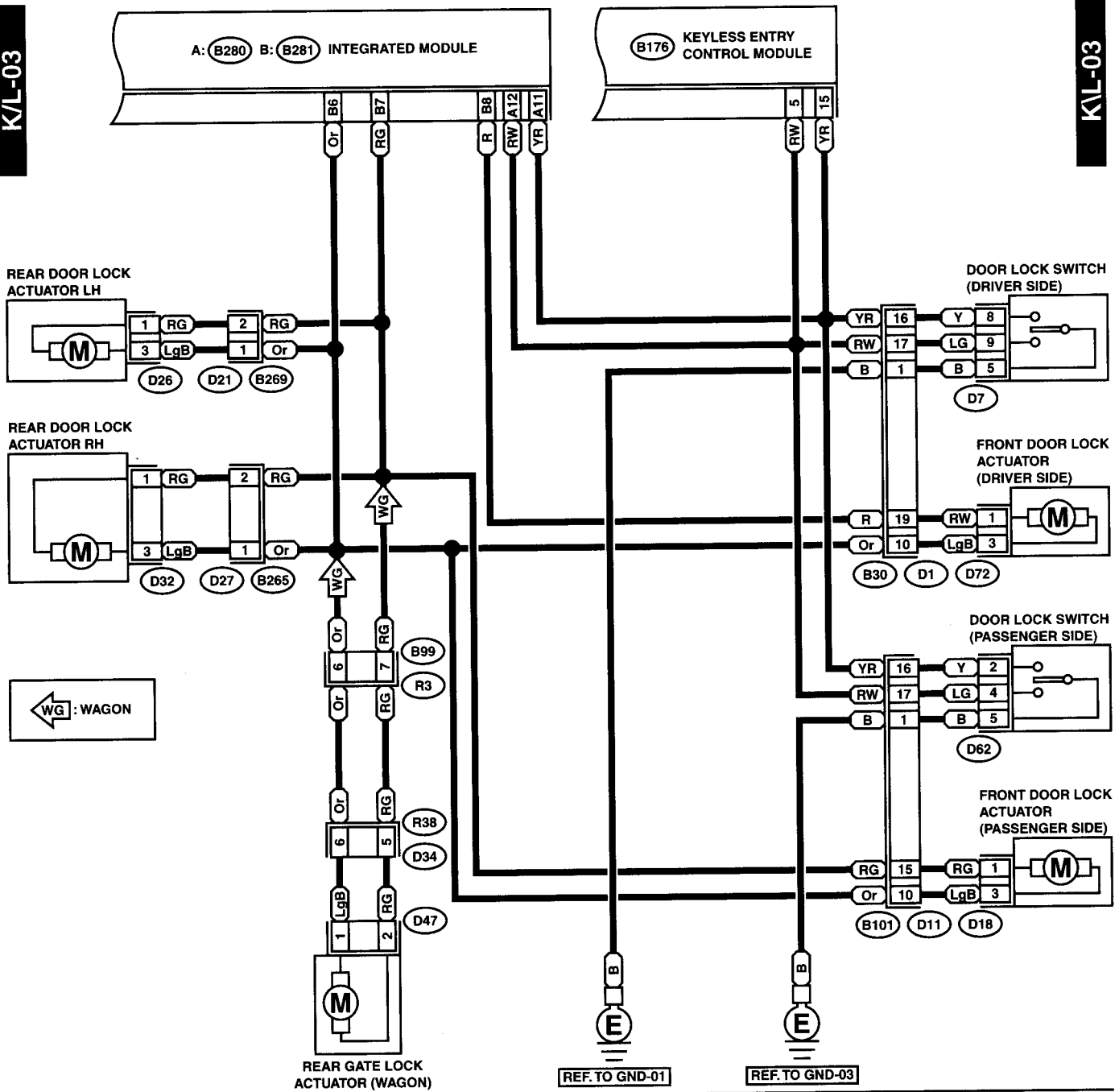

GU77-20C

24.Back-up Light System

A: SCHEMATIC

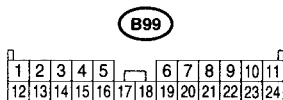
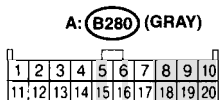
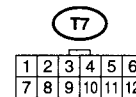
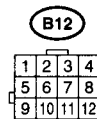
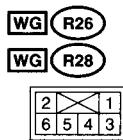
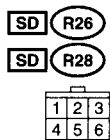
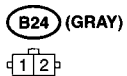
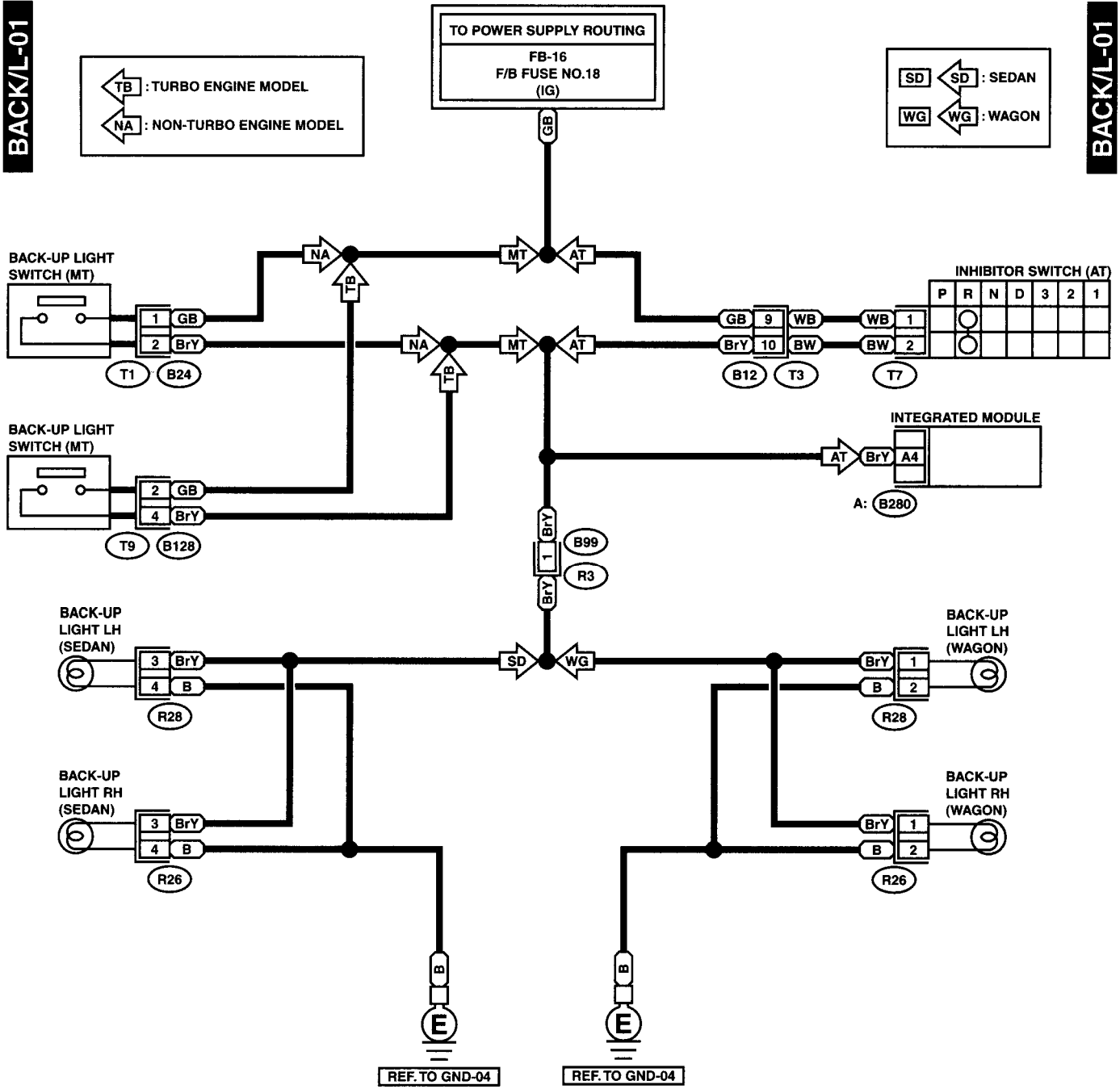

CLEARANCE LIGHT AND ILLUMINATION LIGHT SYSTEM

WIRING SYSTEM

25. Clearance Light and Illumination Light System

A: SCHEMATIC

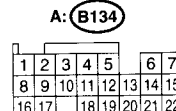
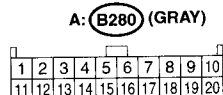
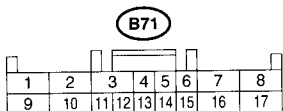
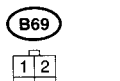
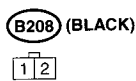
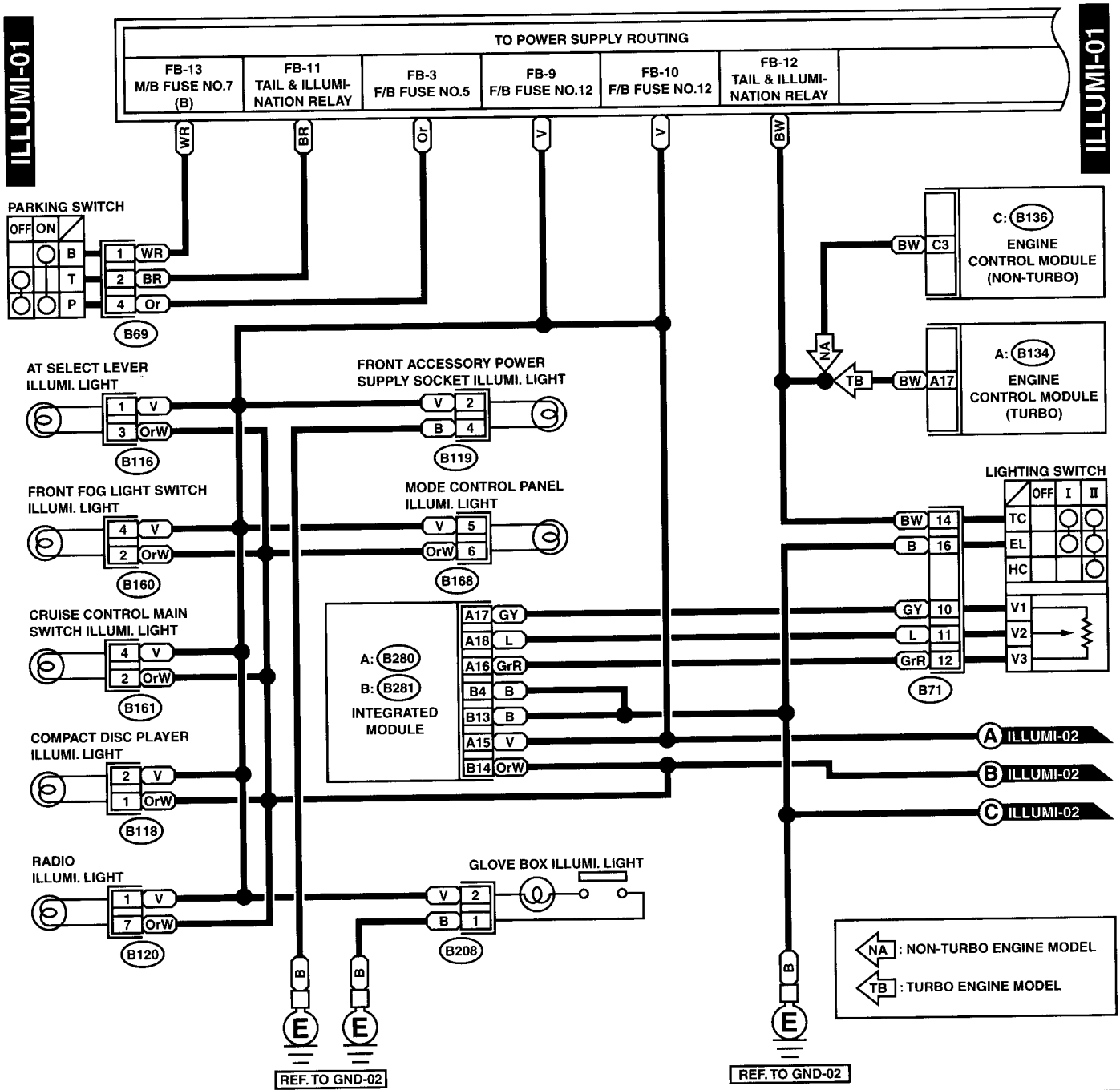

GU21-20A

CLEARANCE LIGHT AND ILLUMINATION LIGHT SYSTEM

WIRING SYSTEM

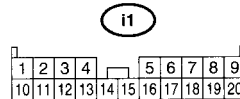
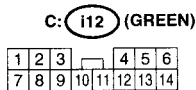
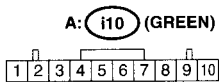
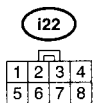
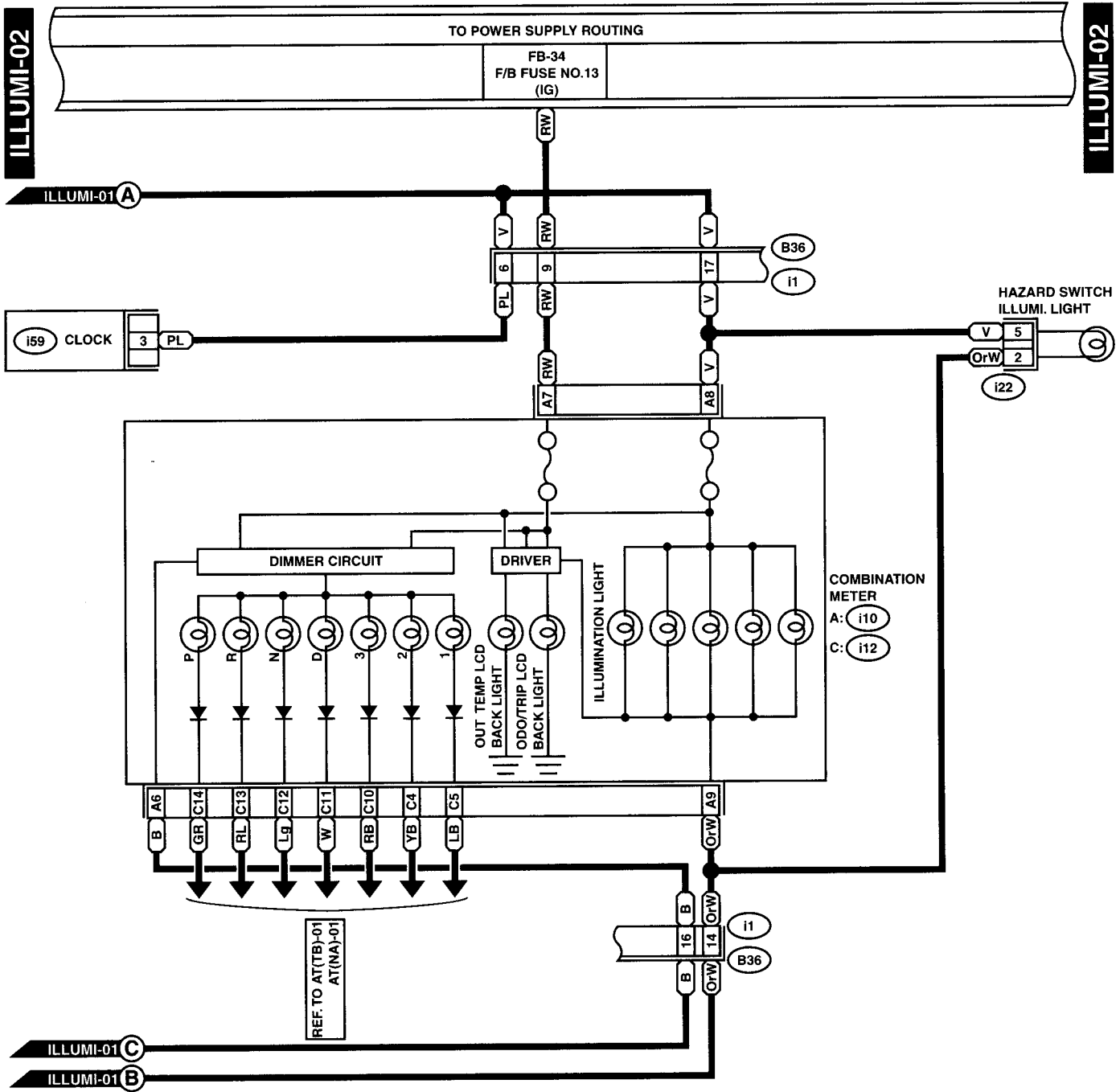

CLEARANCE LIGHT AND ILLUMINATION LIGHT SYSTEM

WIRING SYSTEM

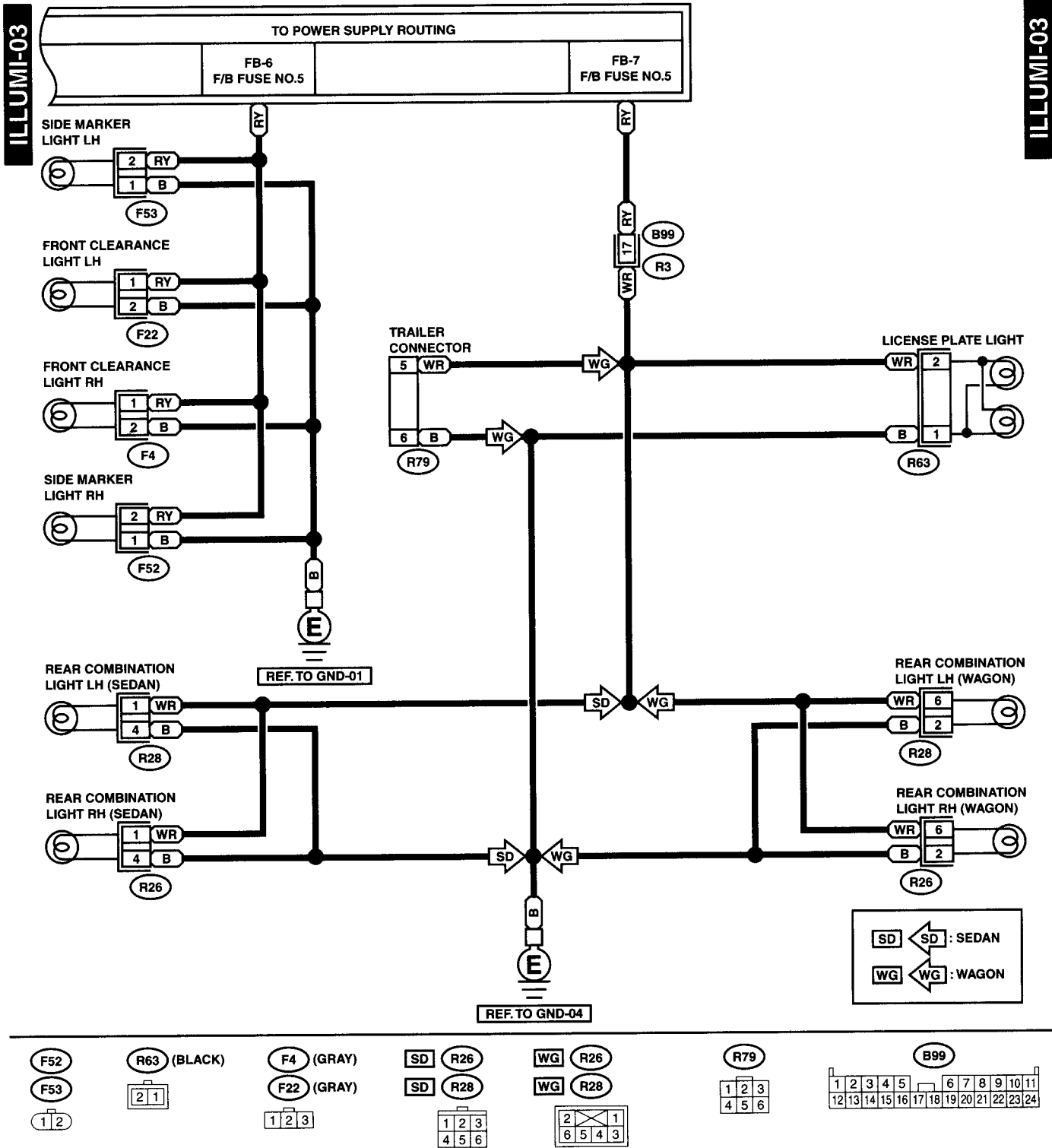

26. Front Fog Light System

A: SCHEMATIC

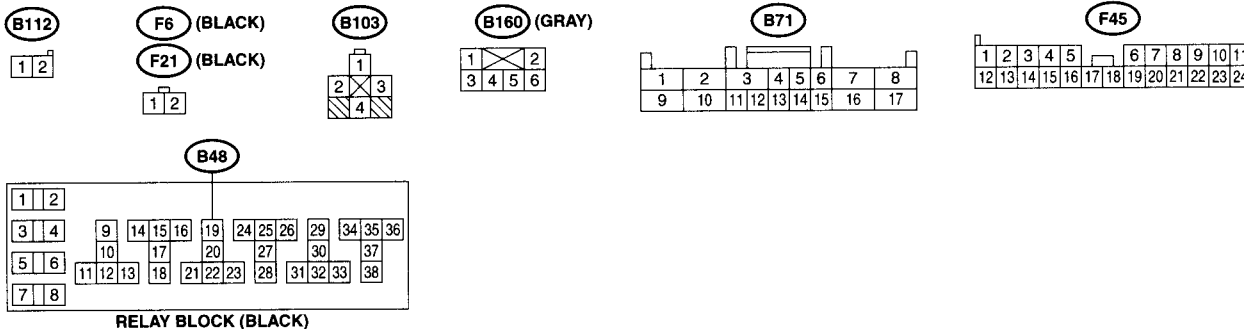
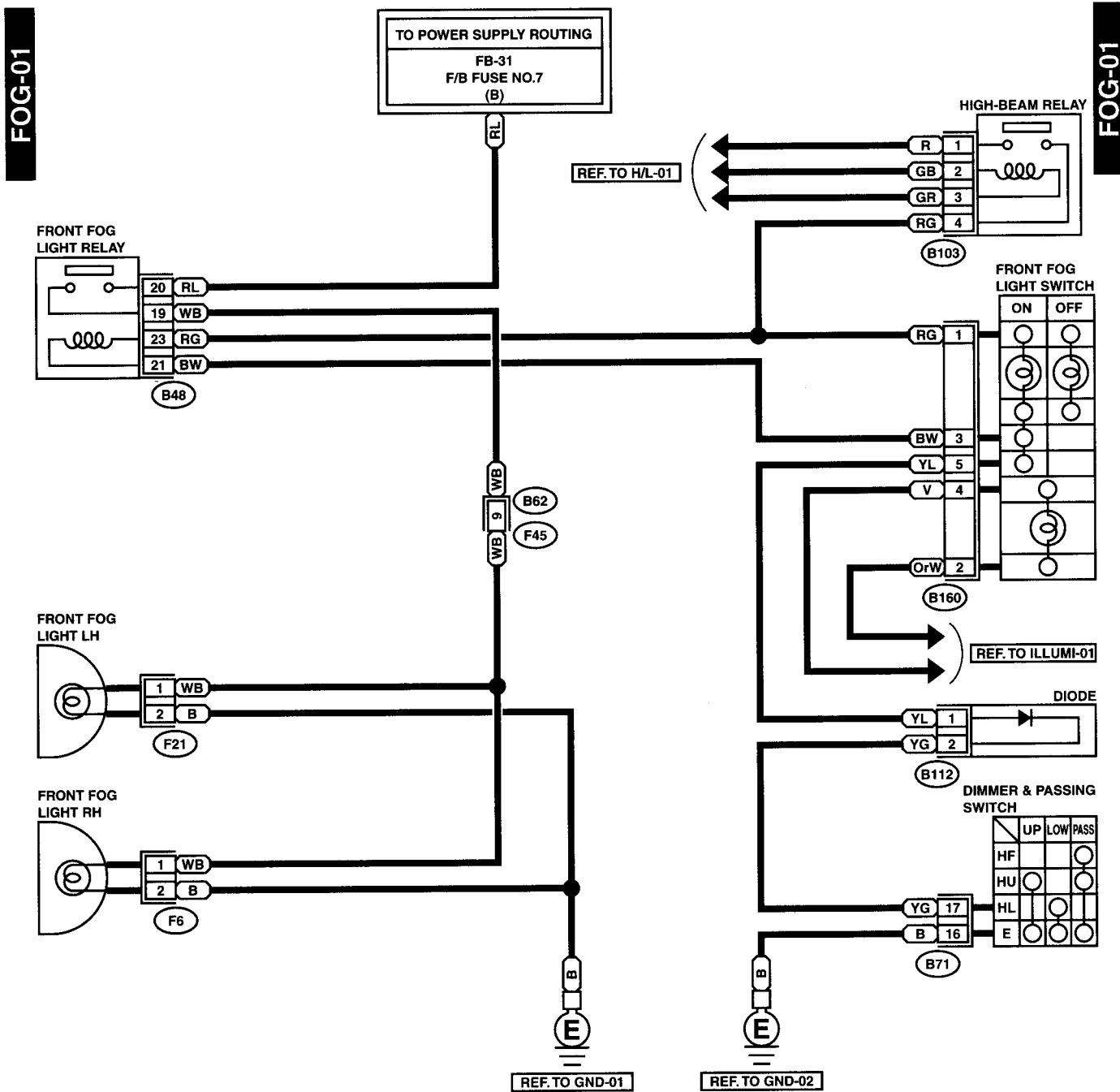

HEADLIGHT SYSTEM

WIRING SYSTEM

27. Headlight System

A: SCHEMATIC

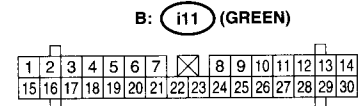
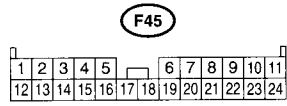
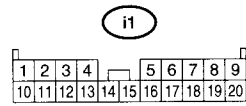
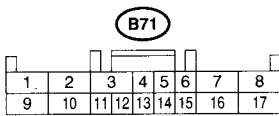
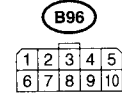
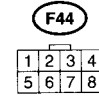
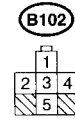
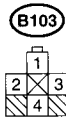
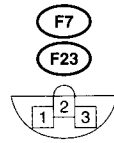
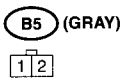
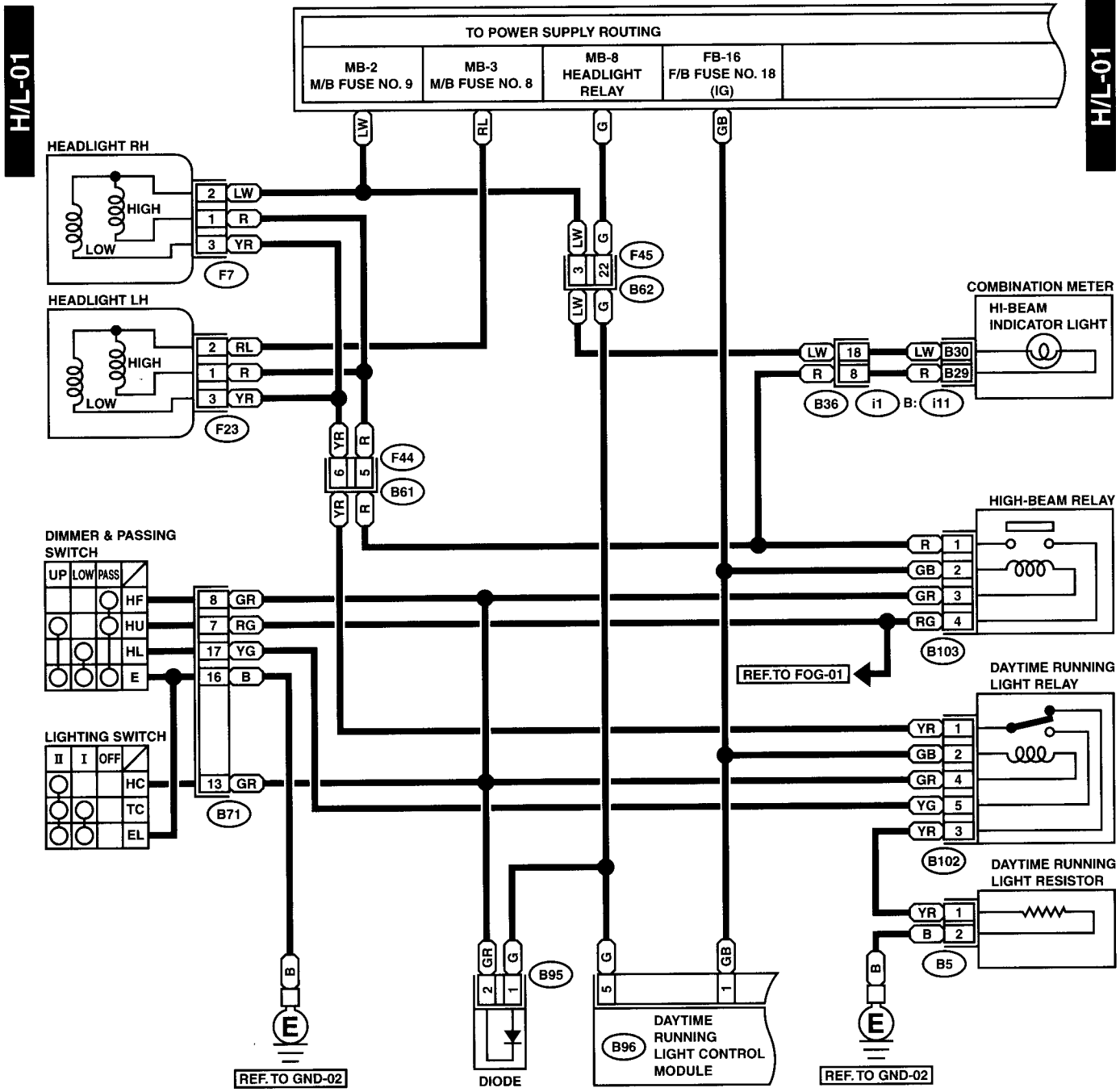

HEADLIGHT SYSTEM

WIRING SYSTEM

H/L-02

H/L-02

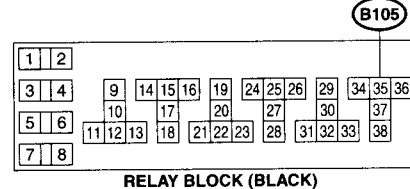
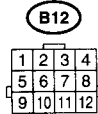
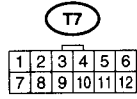
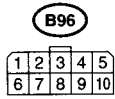
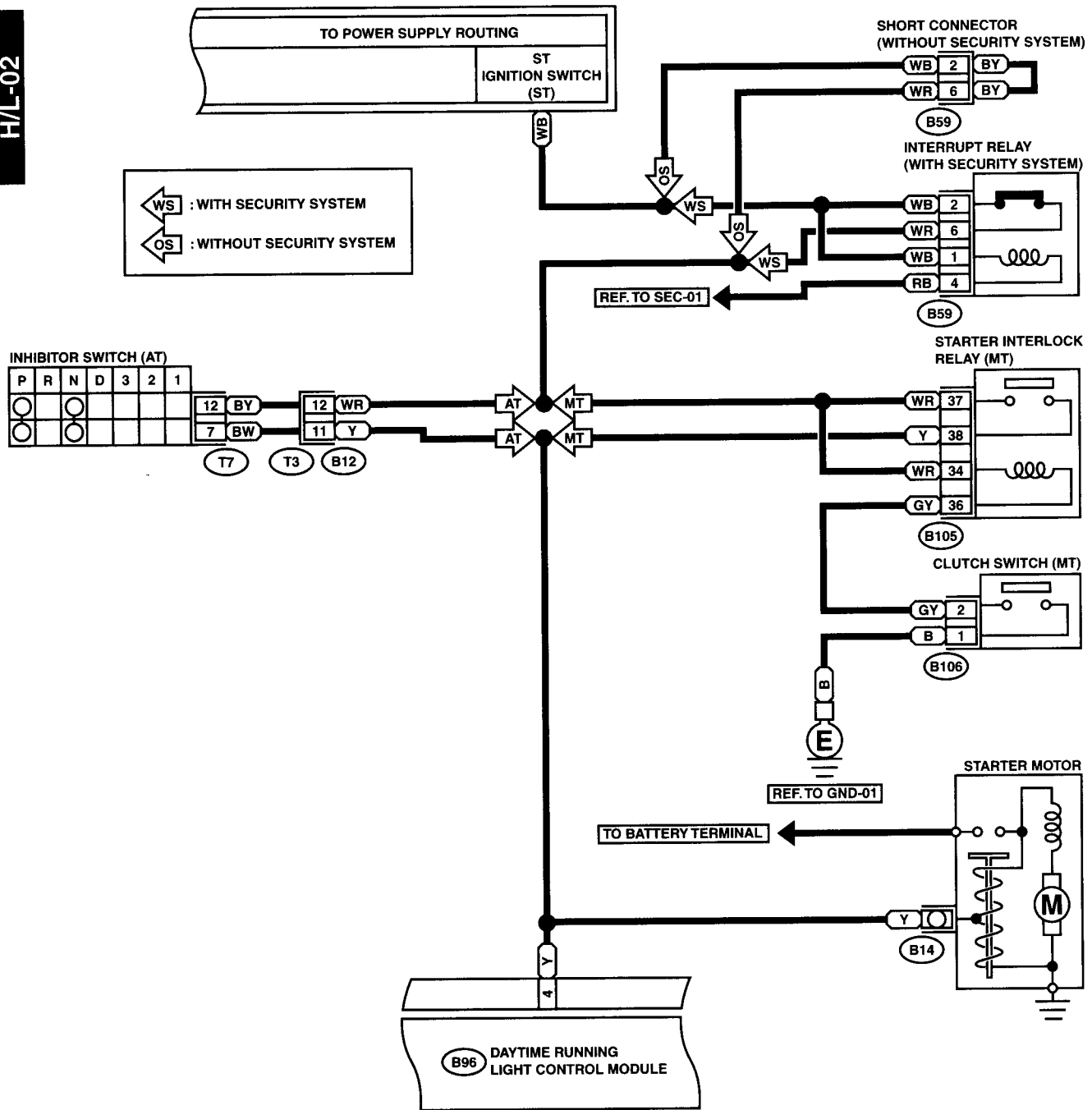

GU18-20B

HEADLIGHT SYSTEM

WIRING SYSTEM

H/L-03

H/L-03

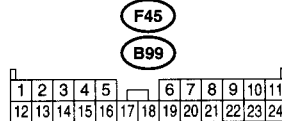
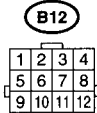
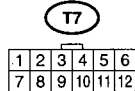
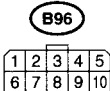
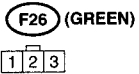
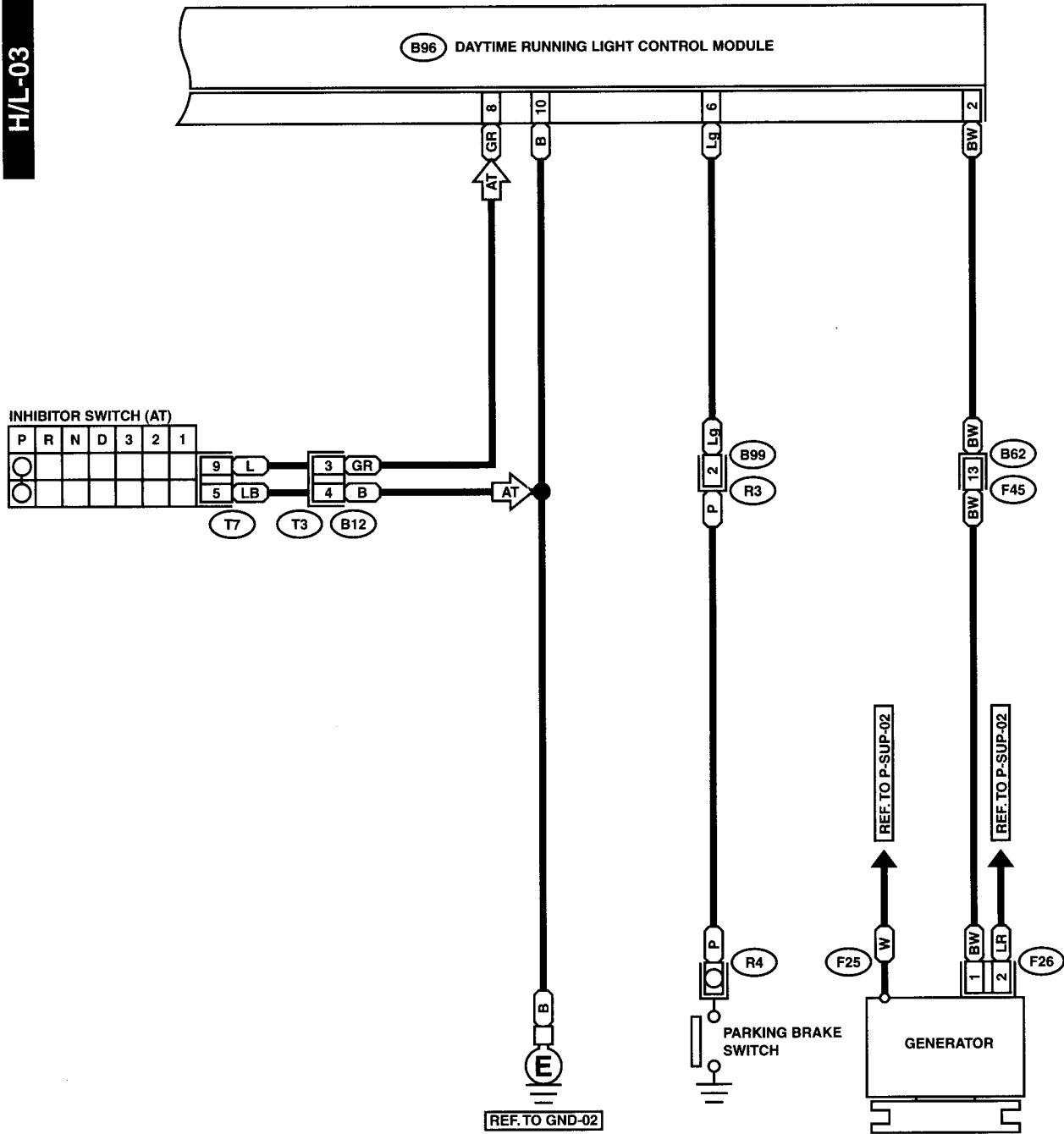

GU18-20C

28.In Compartment Light System

A: SCHEMATIC

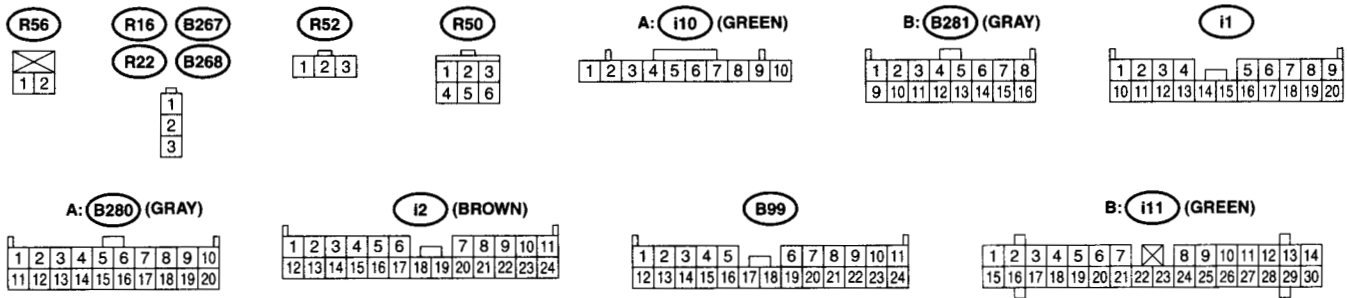
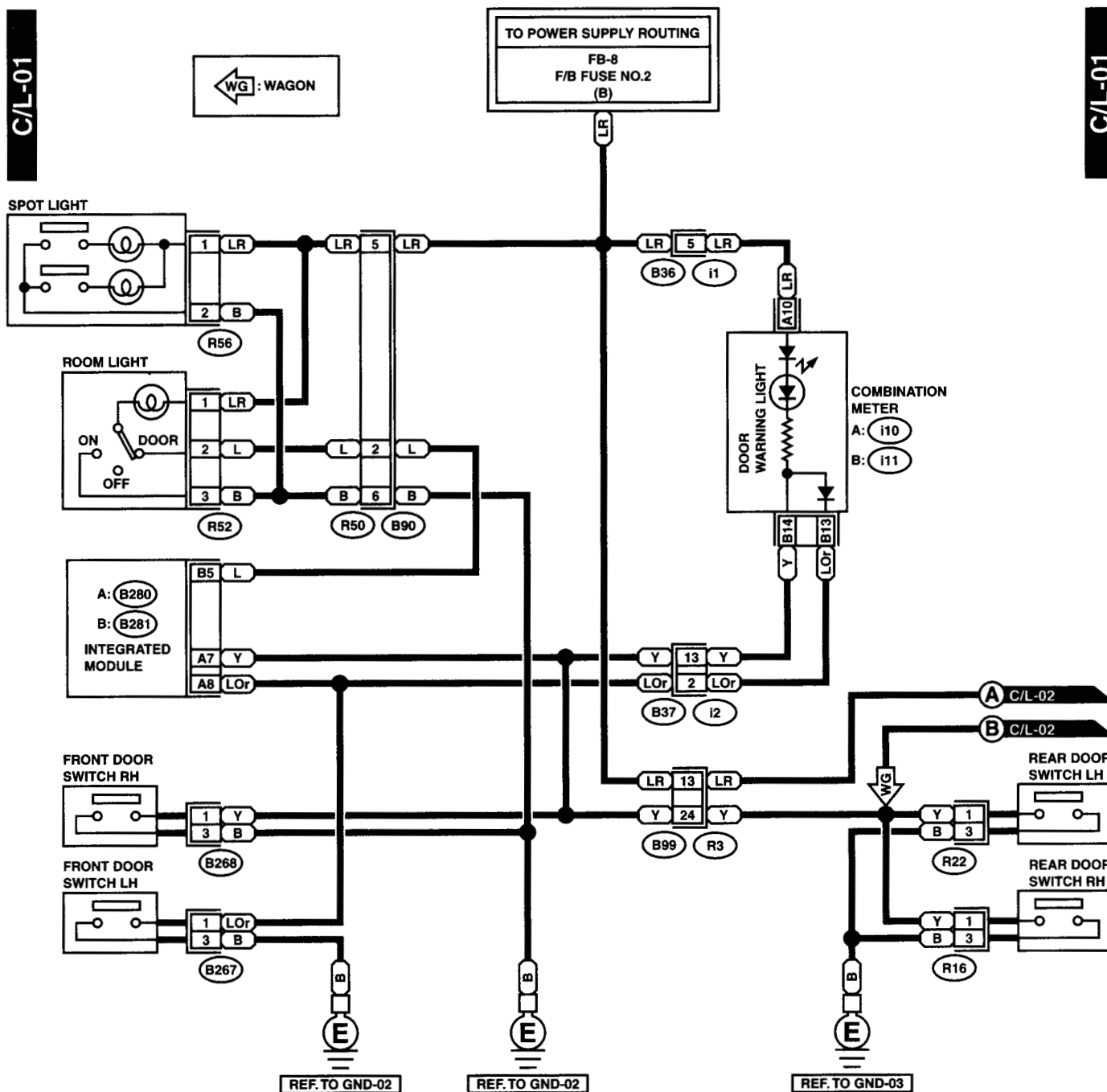

IN COMPARTMENT LIGHT SYSTEM

WIRING SYSTEM

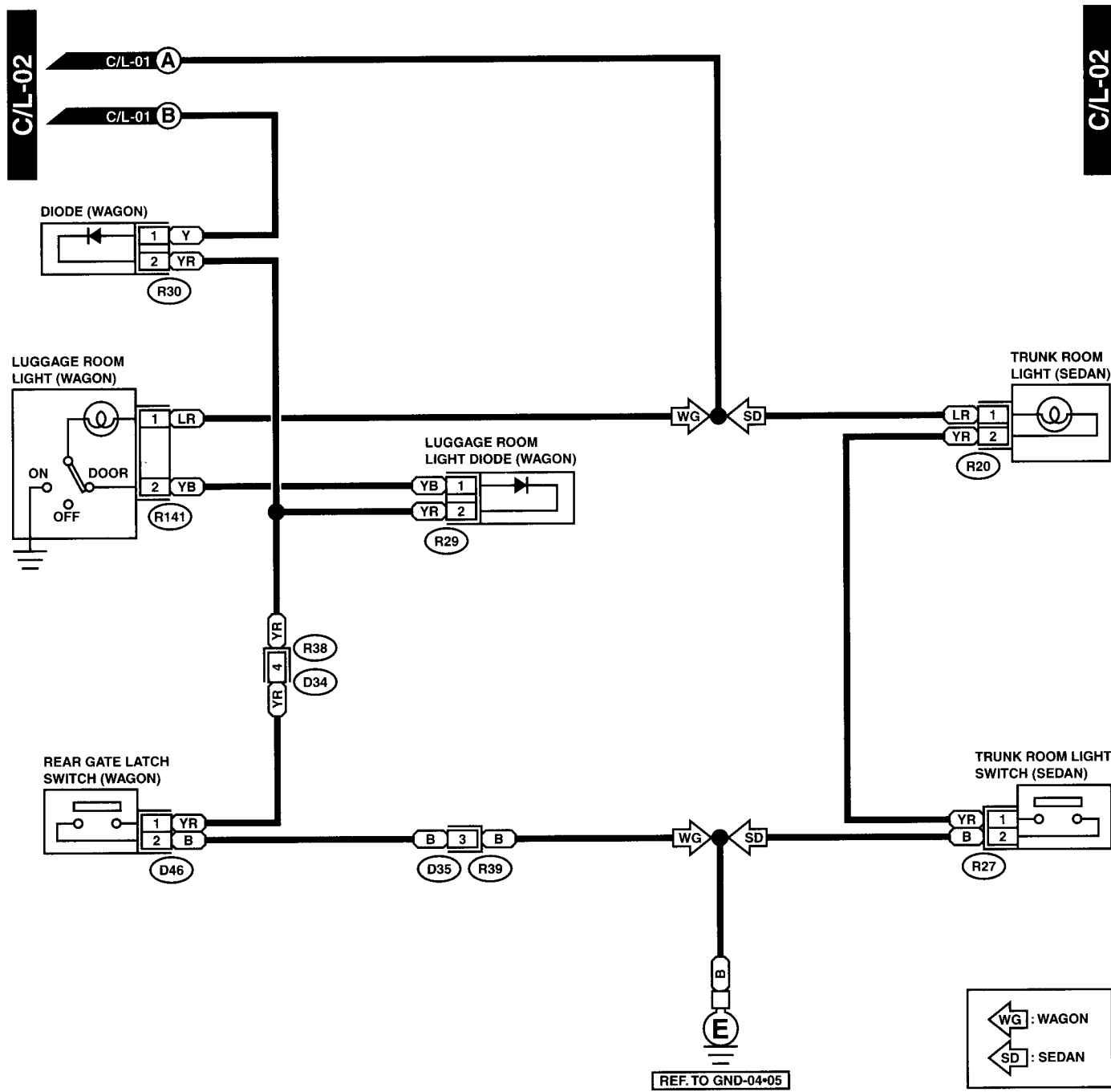

REF. TO GND-04*05

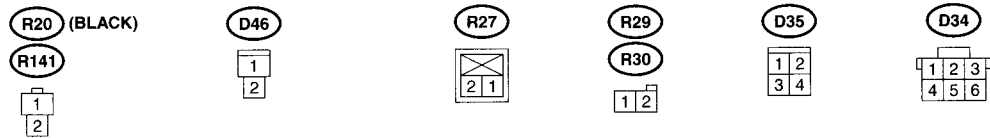
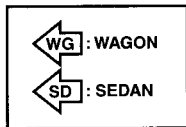

GU24-20B

29. Stop Light System

A: SCHEMATIC

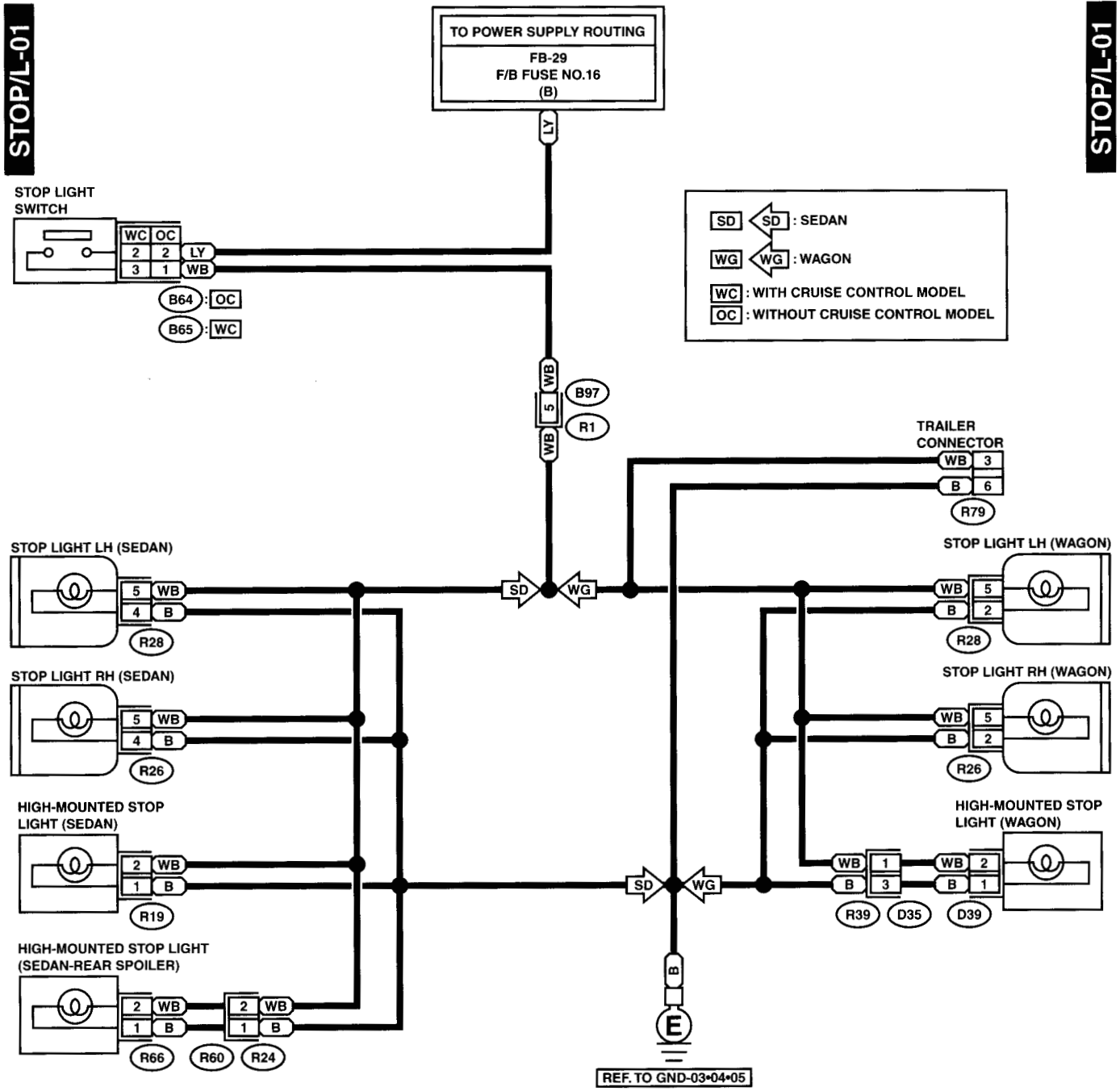

STOP/L-01

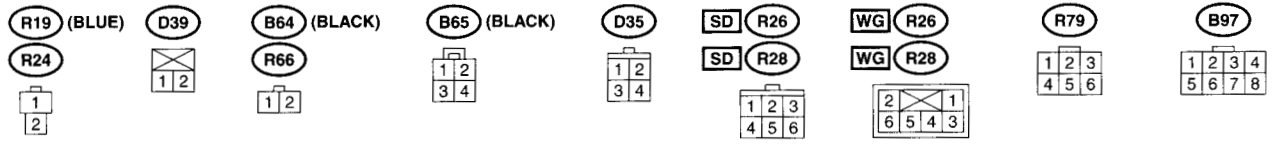

TURN SIGNAL LIGHT AND HAZARD LIGHT SYSTEM

WIRING SYSTEM

30. Turn Signal Light and Hazard Light System

A: SCHEMATIC

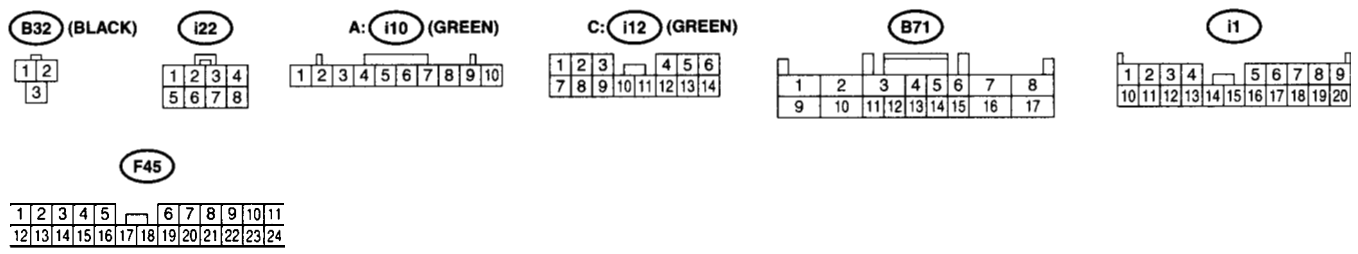
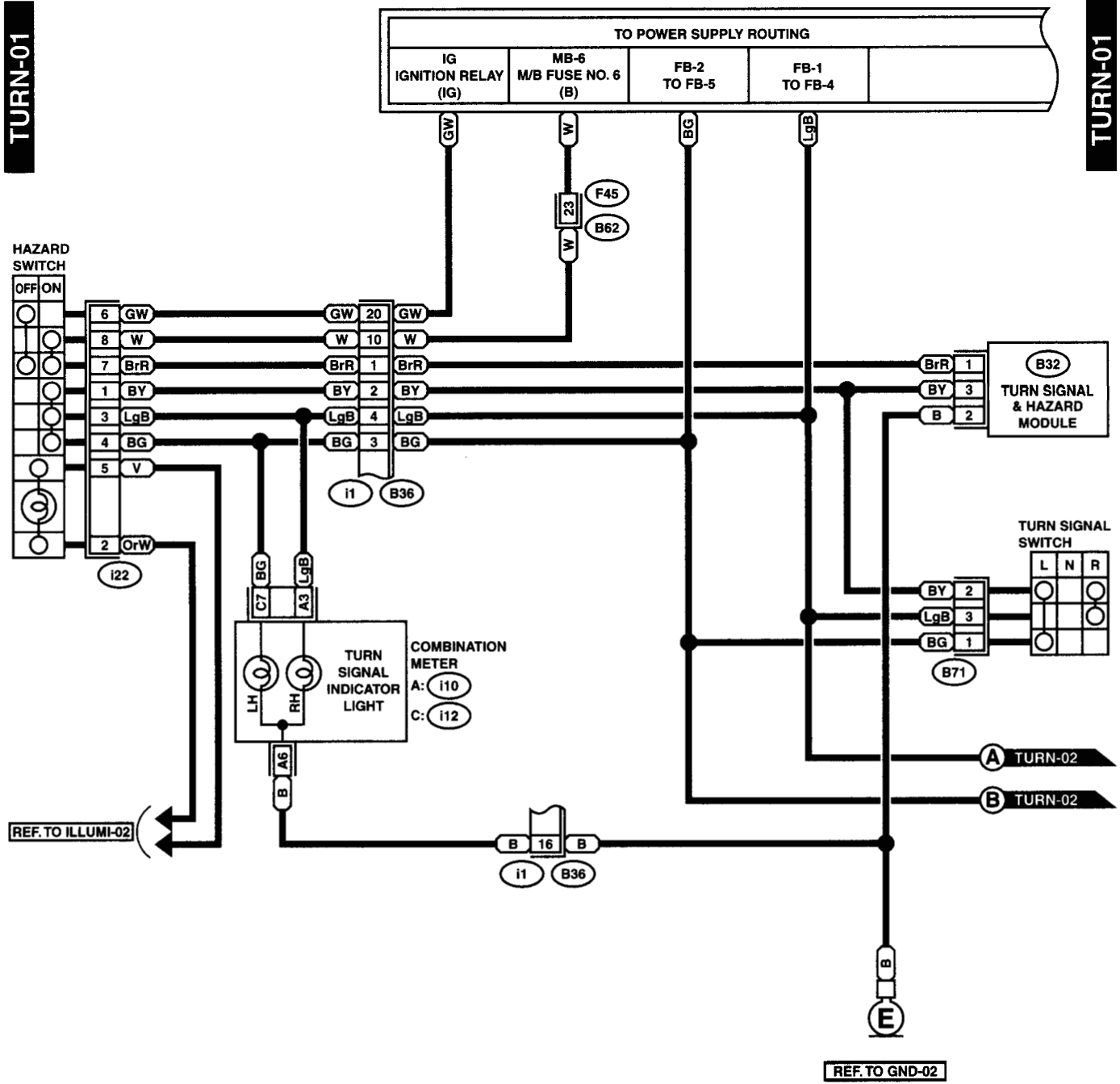

TURN SIGNAL LIGHT AND HAZARD LIGHT SYSTEM

WIRING SYSTEM

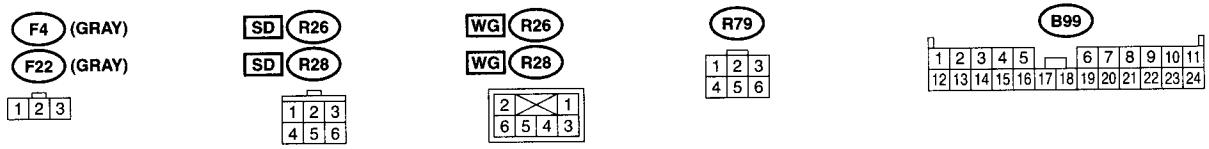
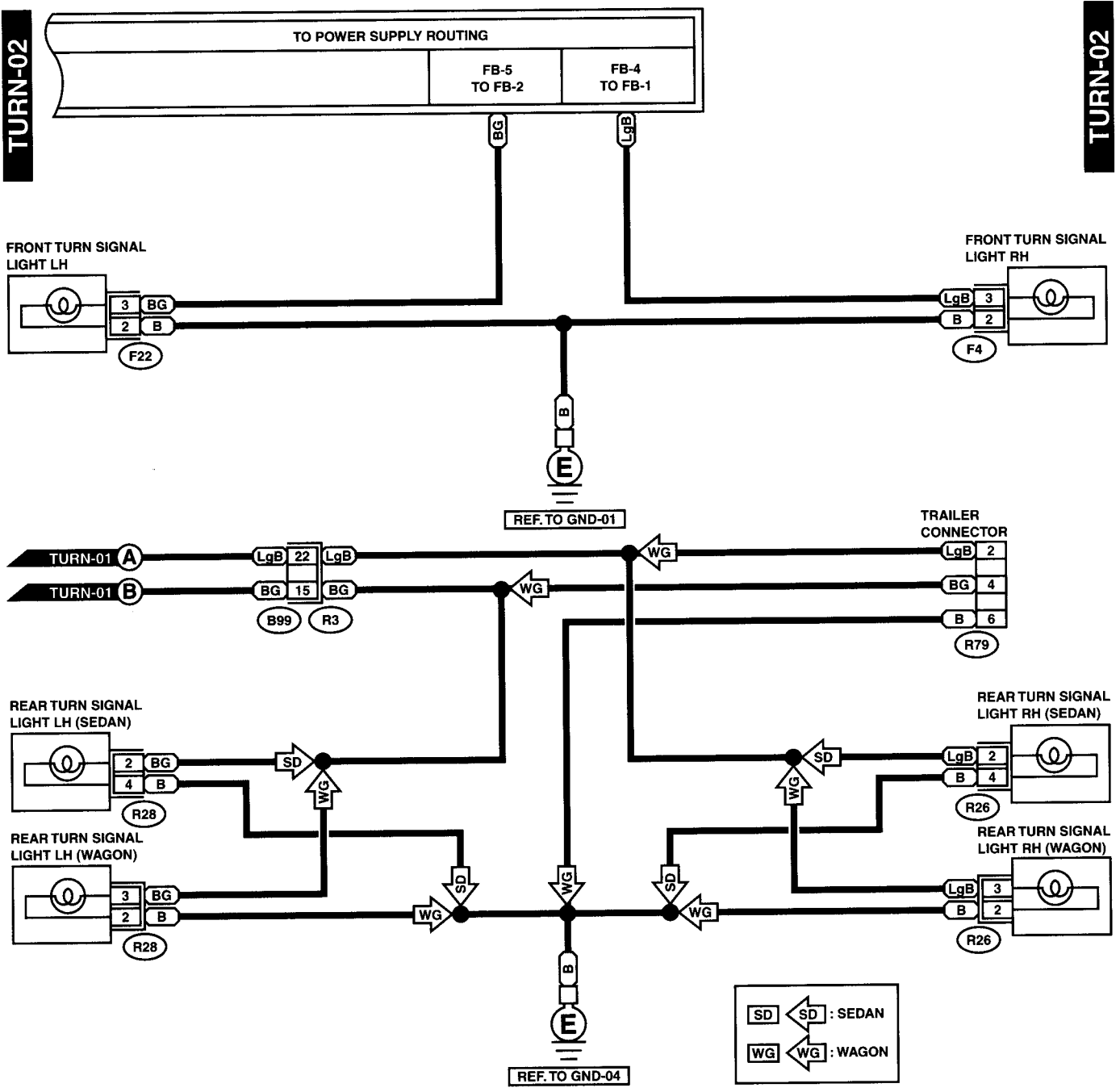

GU26-20B

OIL PRESSURE WARNING LIGHT SYSTEM

WIRING SYSTEM

31.Oil Pressure Warning Light System

A: SCHEMATIC

OIL/P-01

OIL/P-01

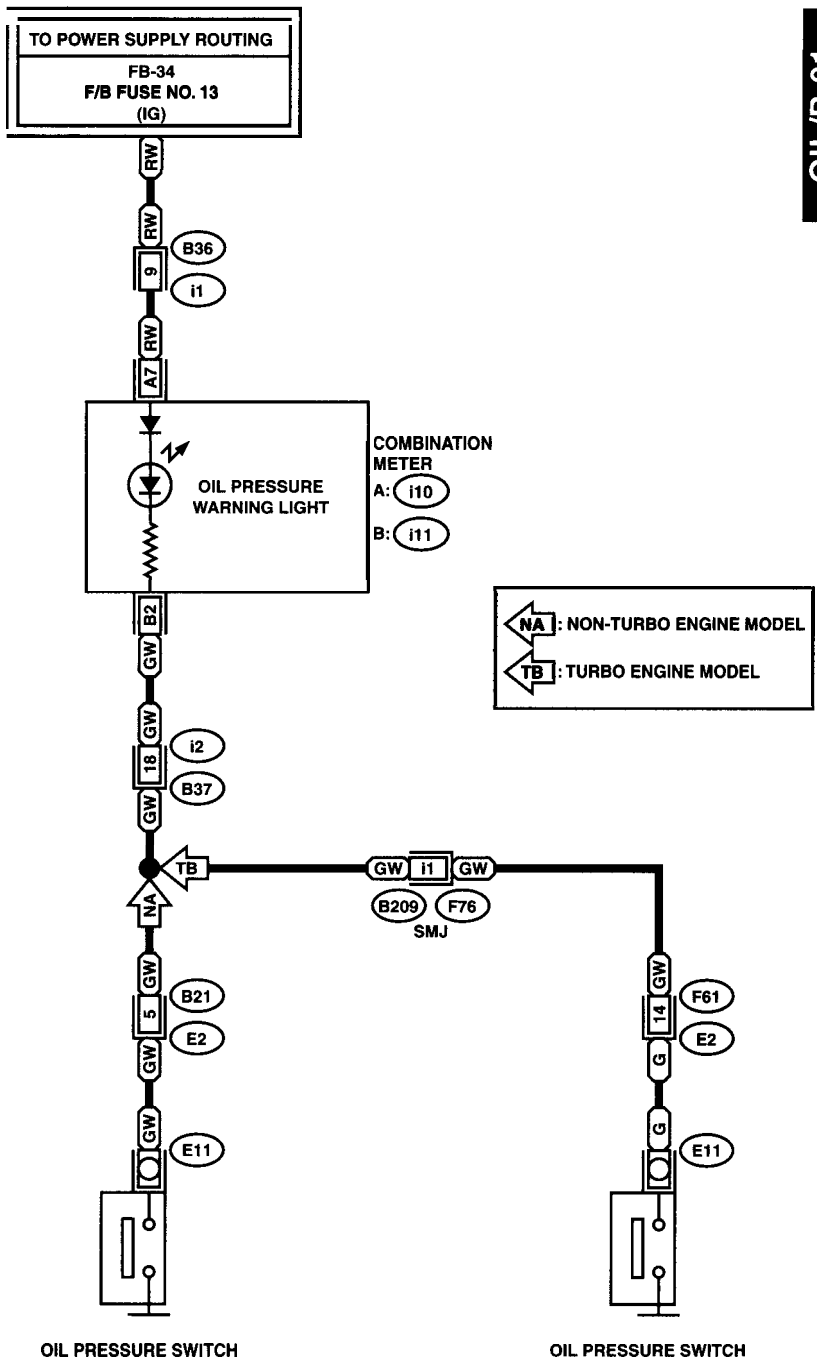

← NA : NON-TURBO ENGINE MODEL
 ← TB : TURBO ENGINE MODEL

OIL PRESSURE SWITCH

OIL PRESSURE SWITCH

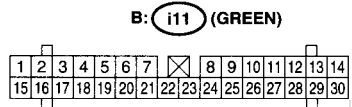
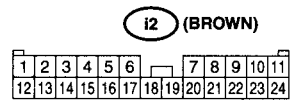
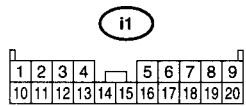
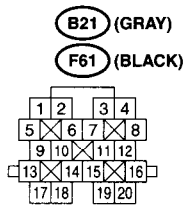
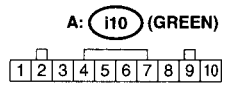

32. Outside Temperature Display System

A: SCHEMATIC

O/TEMP-01

O/TEMP-01

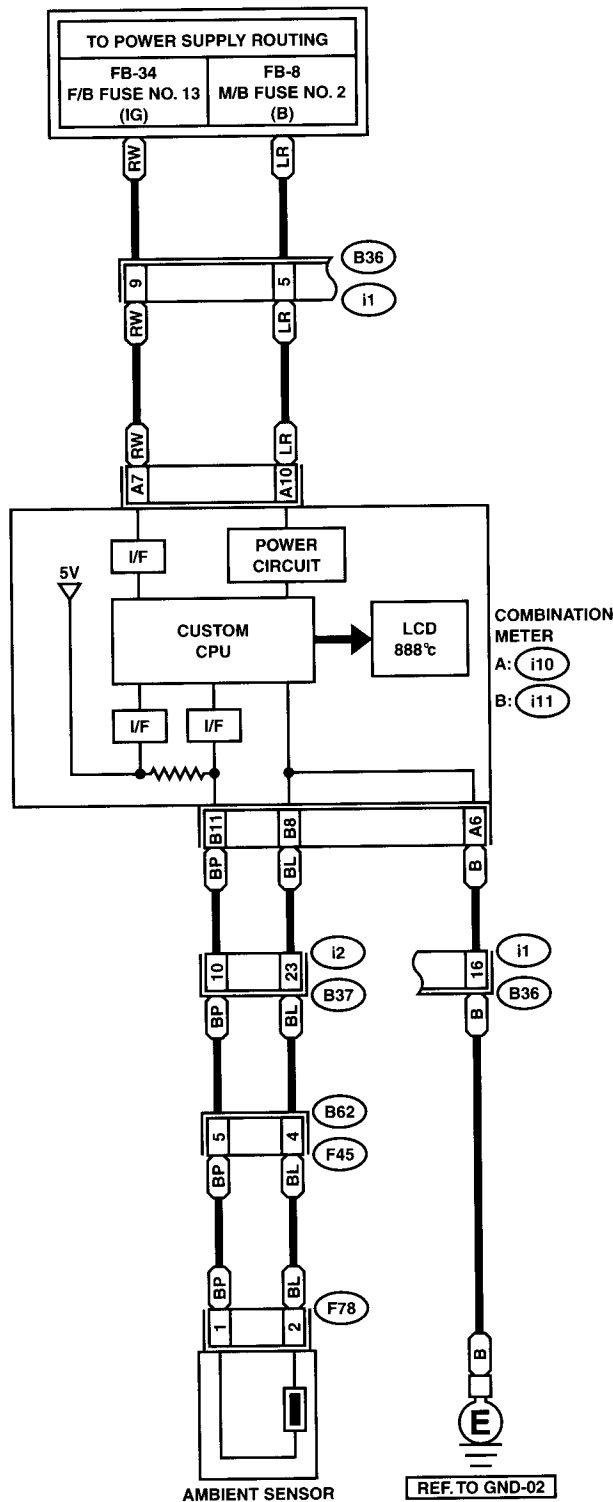

F78 (BLACK) A: i10 (GREEN)

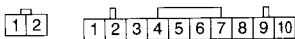

i1

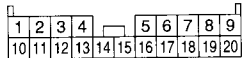

F45



i2 (BROWN)

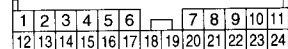

B: i11 (GREEN)

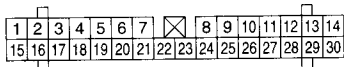

PARKING BRAKE AND BRAKE FLUID LEVEL WARNING SYSTEM

WIRING SYSTEM

33. Parking Brake and Brake Fluid Level Warning System

A: SCHEMATIC

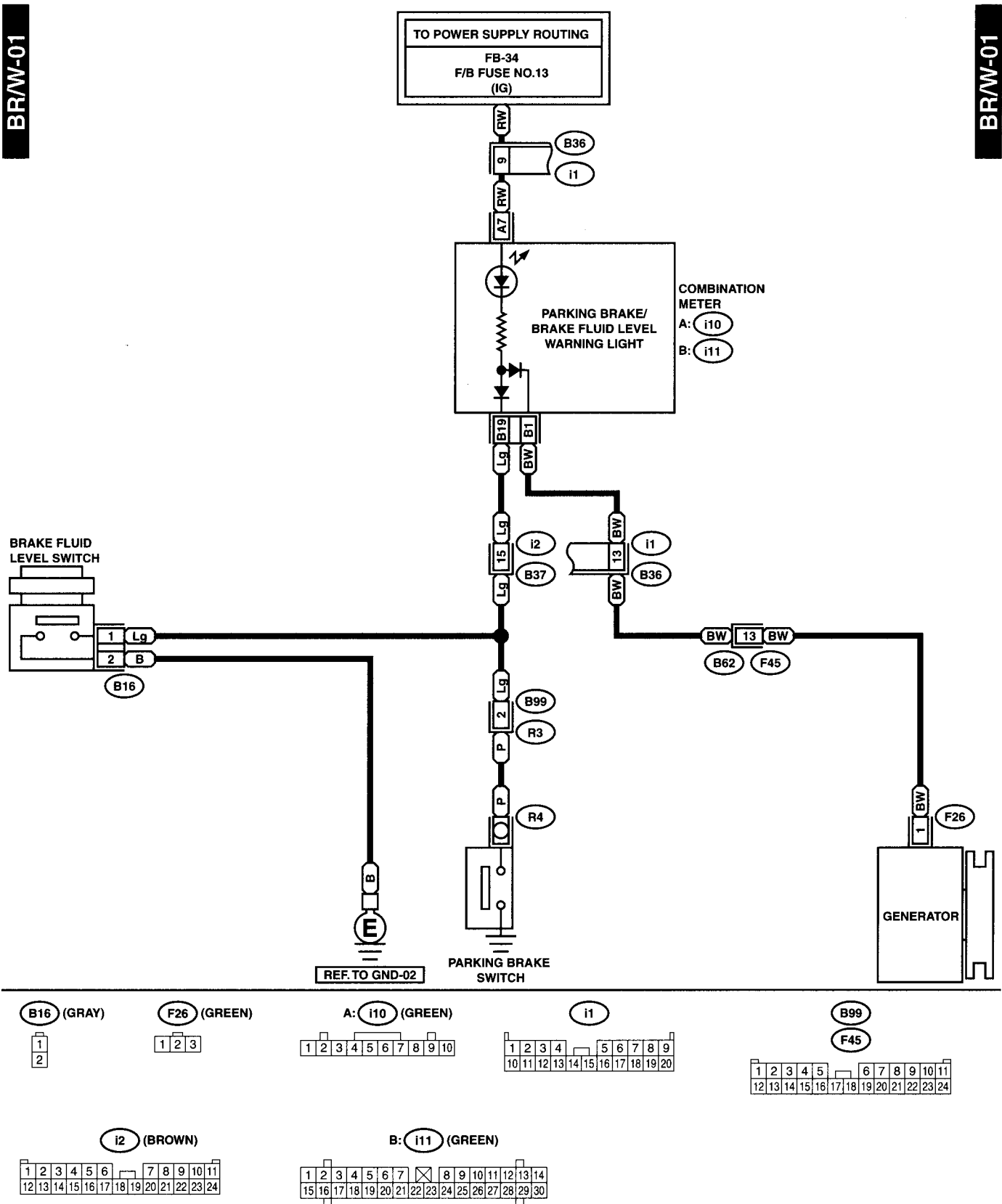

34. Power Window System

A: SCHEMATIC

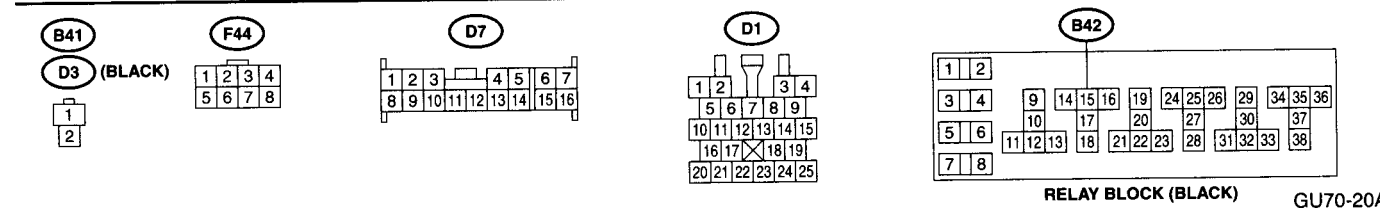
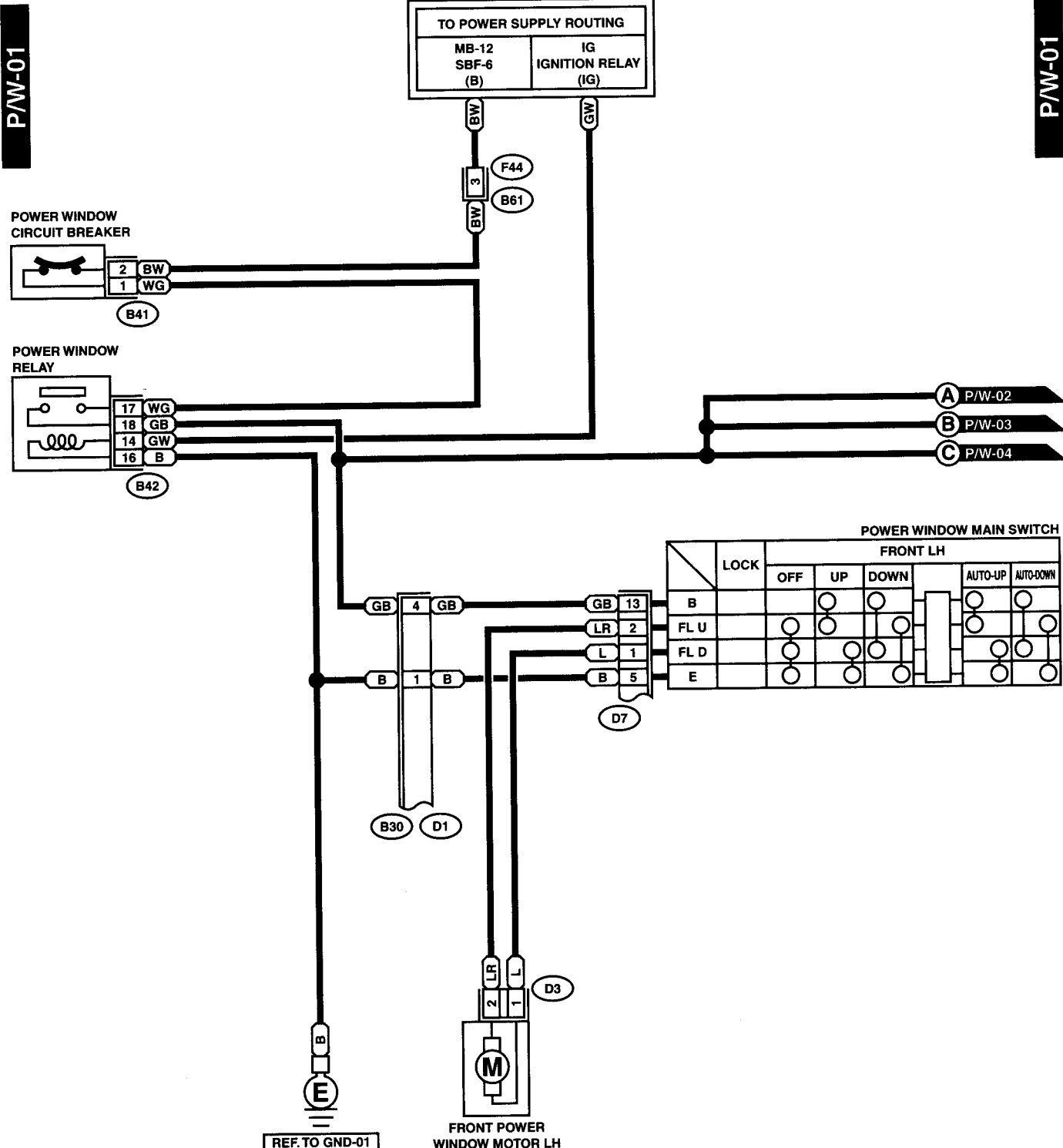

POWER WINDOW SYSTEM

WIRING SYSTEM

P/W-02

P/W-02

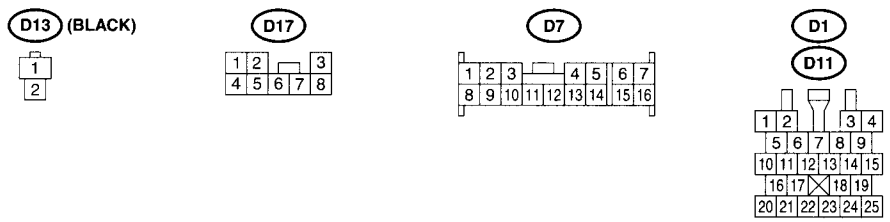
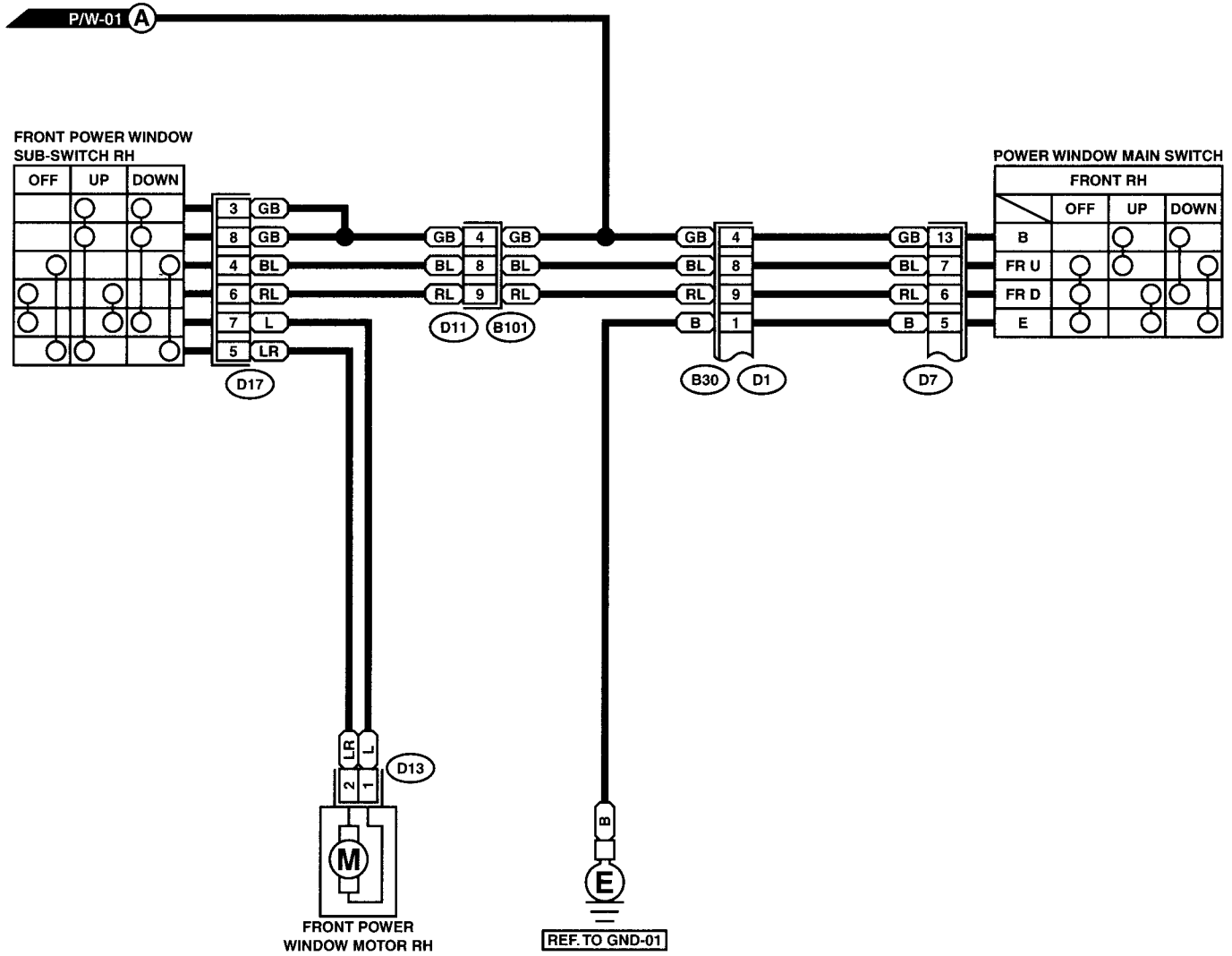

GU70-20B

P/W-03

P/W-03

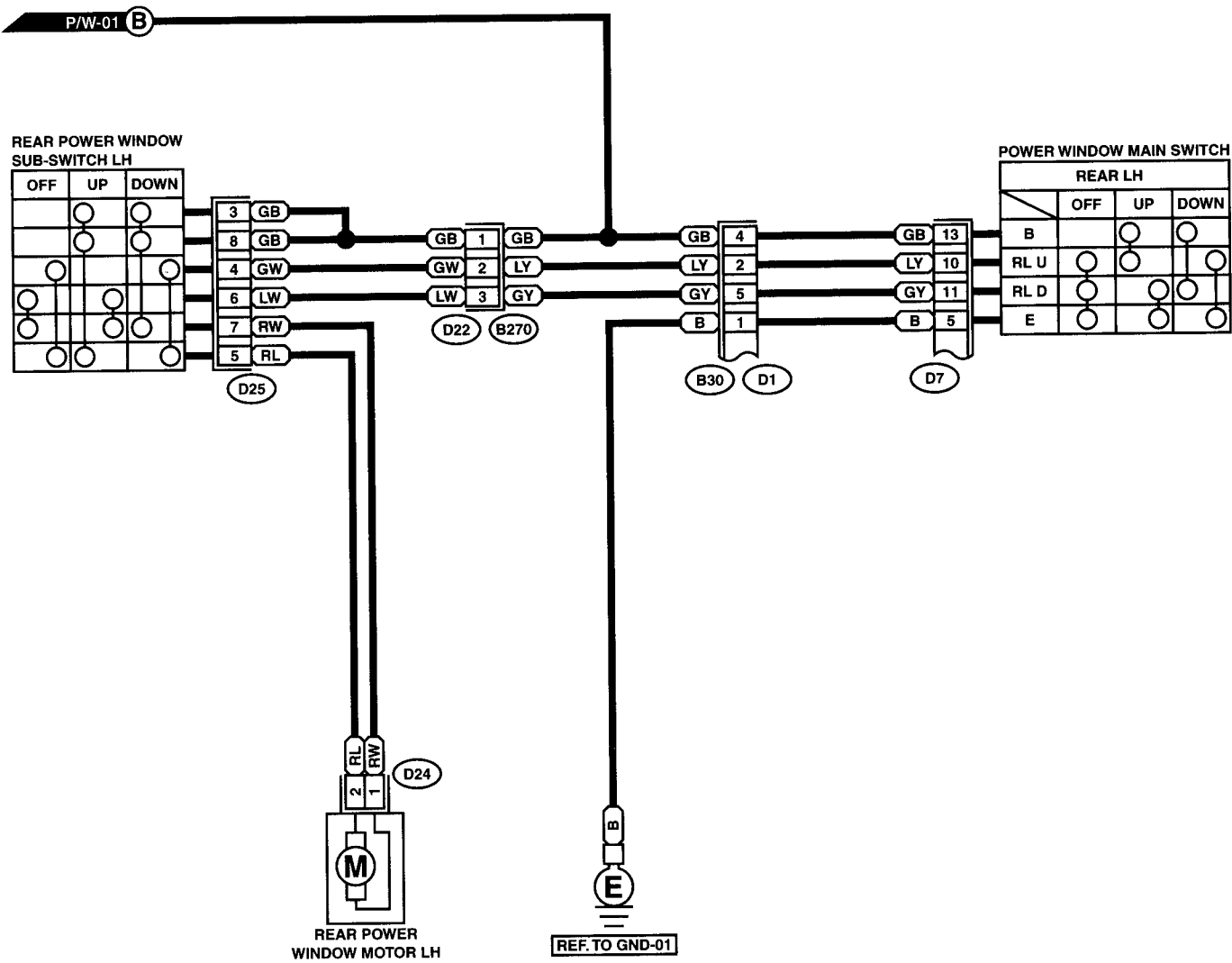

D24 (BLACK)



D22



D25

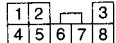

D7

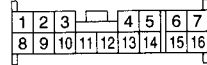

D1

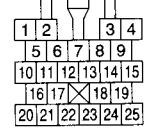

POWER WINDOW SYSTEM

WIRING SYSTEM

P/W-04

P/W-04

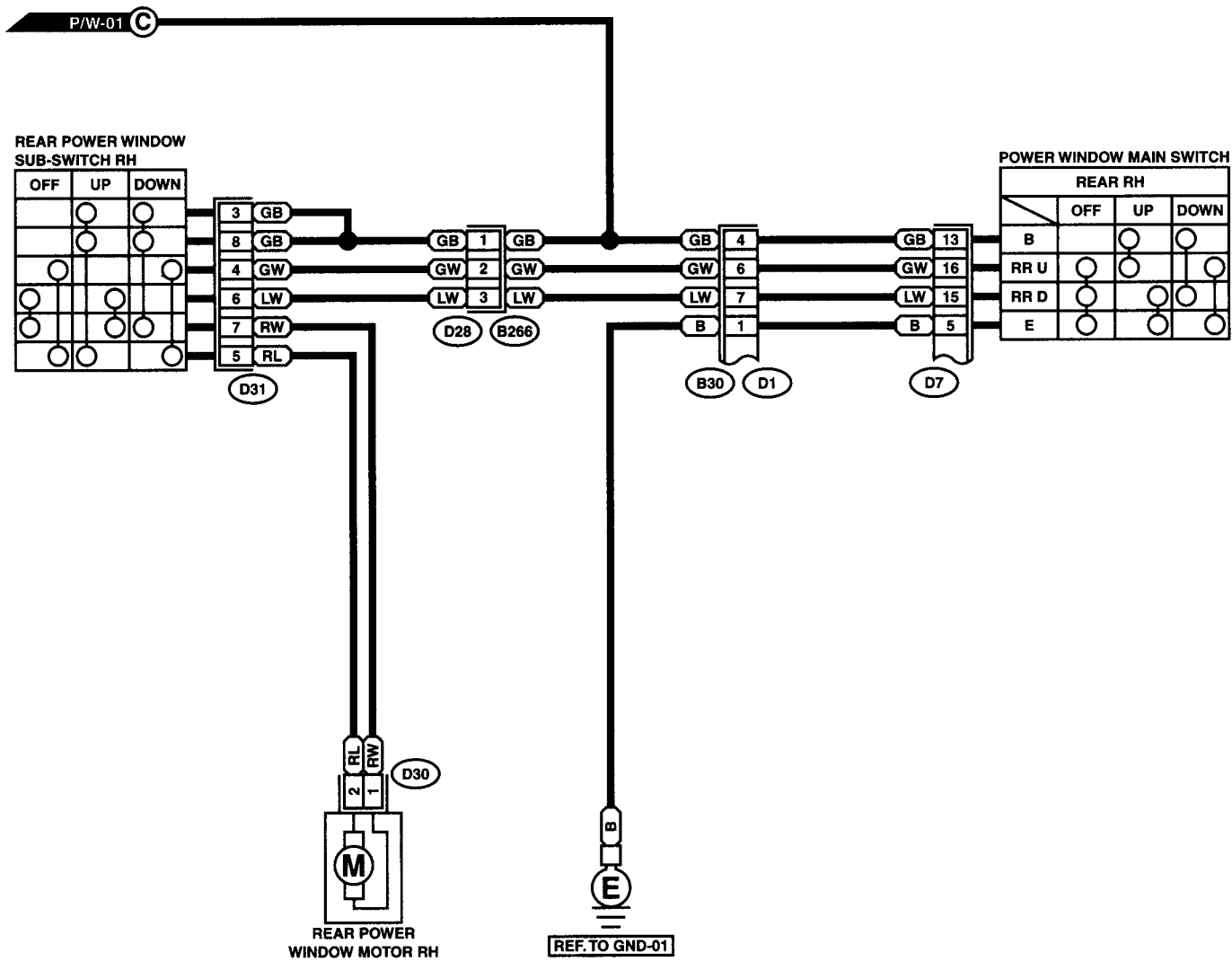

D30 (BLACK)



D28



D31

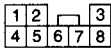

D7

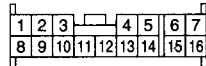

D1

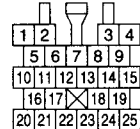

GU70-20D

35.Radiator Fan System

A: SCHEMATIC

RADIATOR FAN SYSTEM

WIRING SYSTEM

1. TURBO ENGINE MODEL

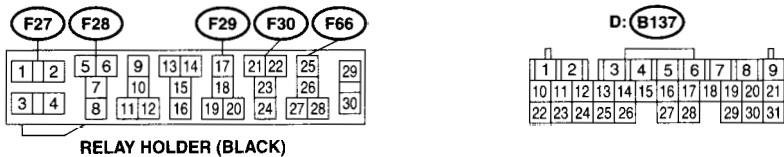
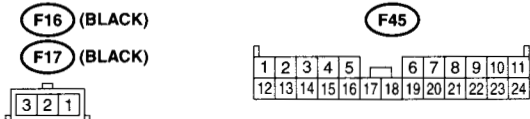
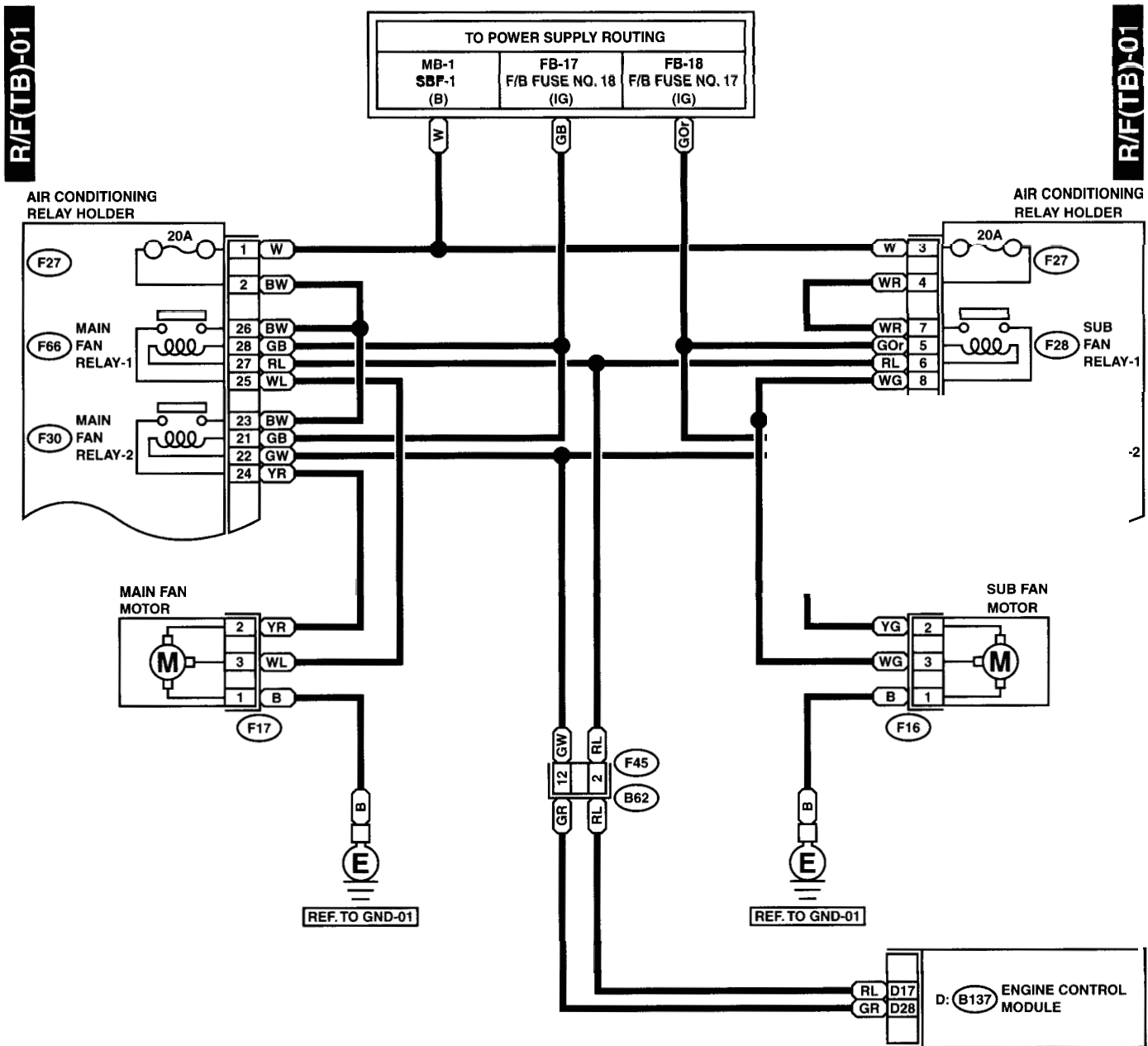

RADIATOR FAN SYSTEM

WIRING SYSTEM

2. NON-TURBO ENGINE MODEL

R/F(NA)-01

R/F(NA)-01

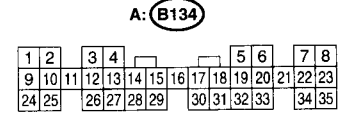
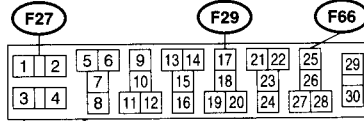
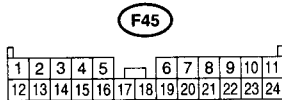
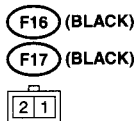
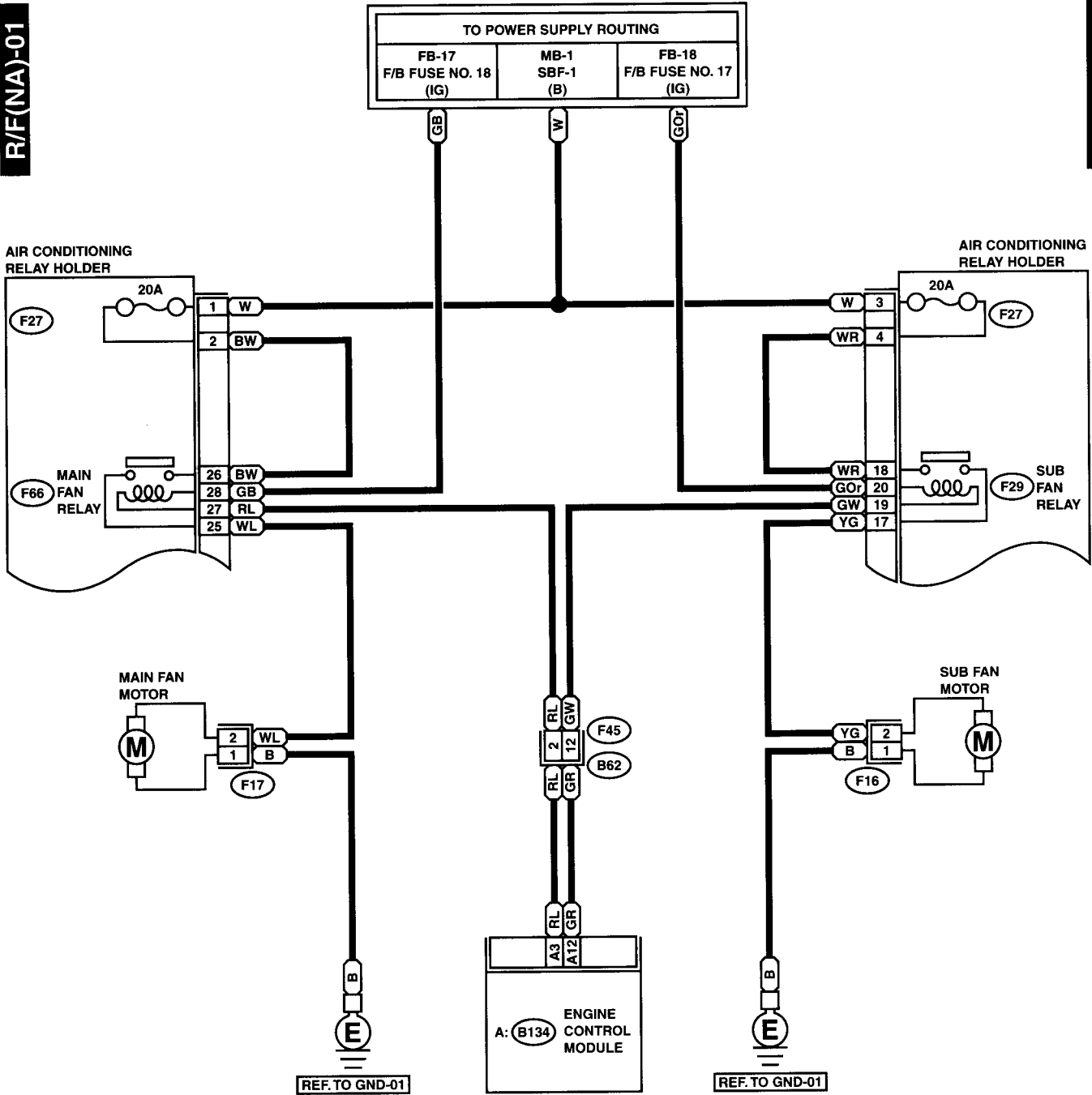

RELAY HOLDER (BLACK)

REAR ACCESSORY POWER SUPPLY SYSTEM

WIRING SYSTEM

36.Rear Accessory Power Supply System

A: SCHEMATIC

RAPS-01

RAPS-01

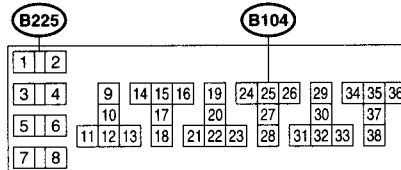
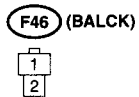
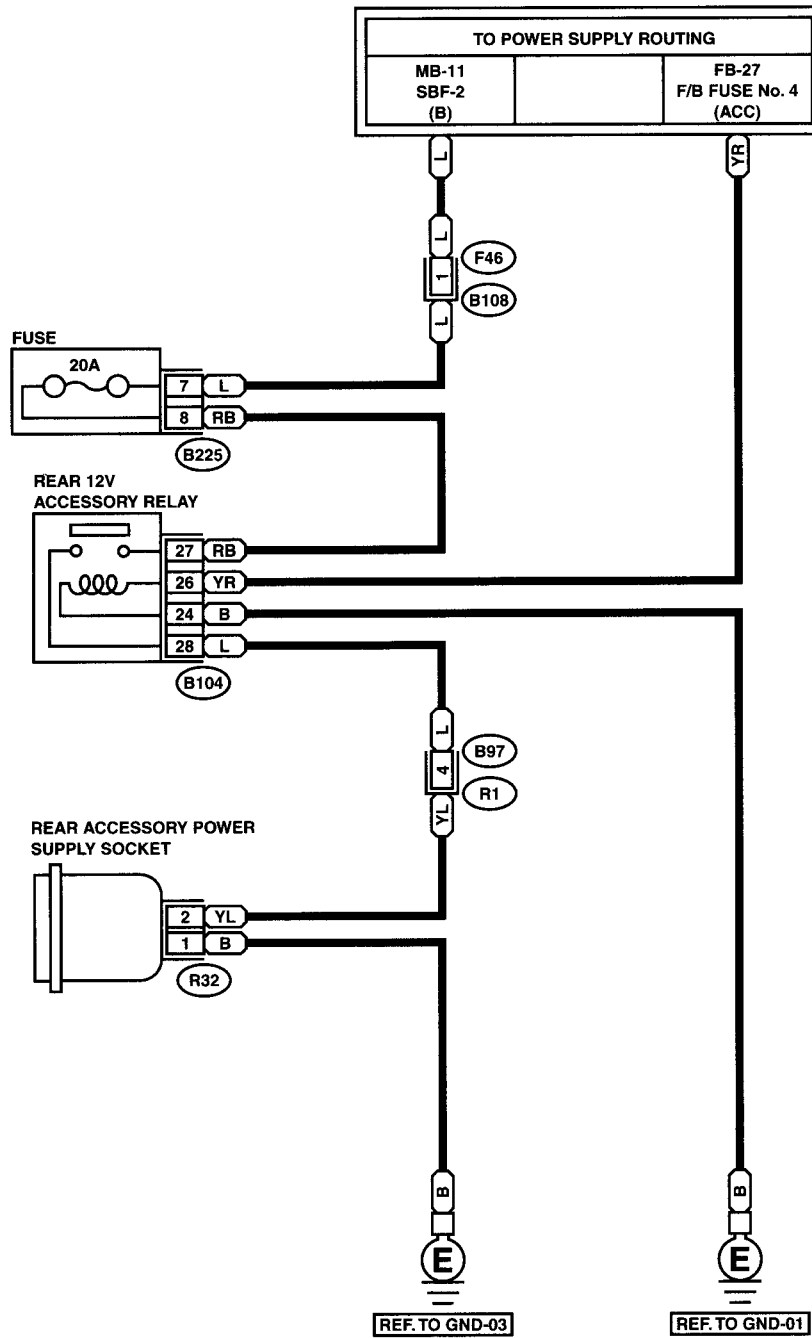

RELAY BLOCK (BLACK)

37. Rear Window Defogger System

A: SCHEMATIC

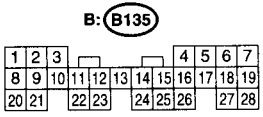
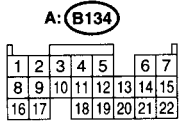
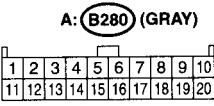
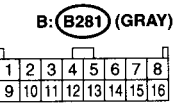
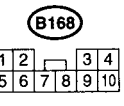
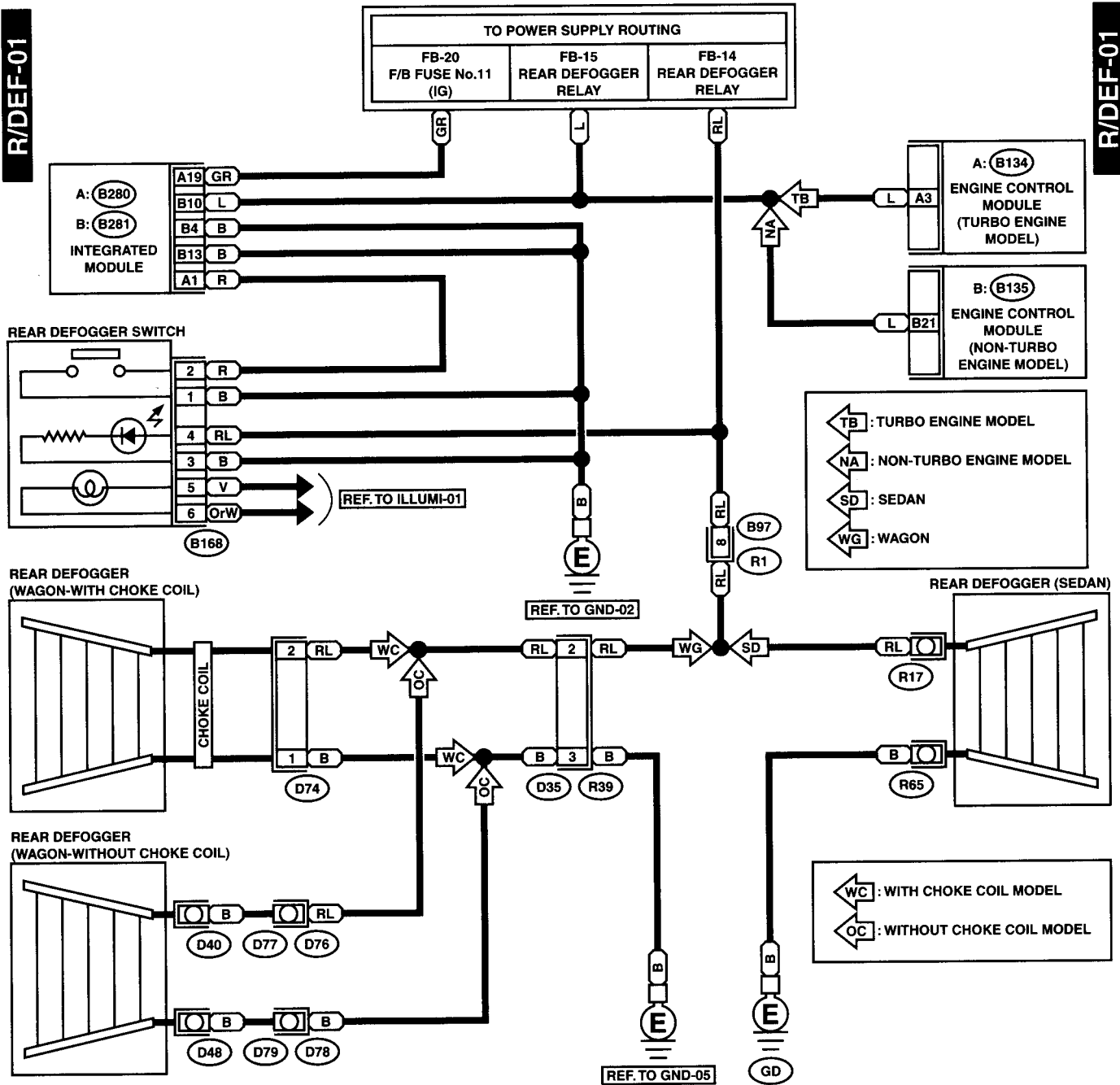

REMOTE CONTROLLED REARVIEW MIRROR SYSTEM

WIRING SYSTEM

38. Remote Controlled Rearview Mirror System

A: SCHEMATIC

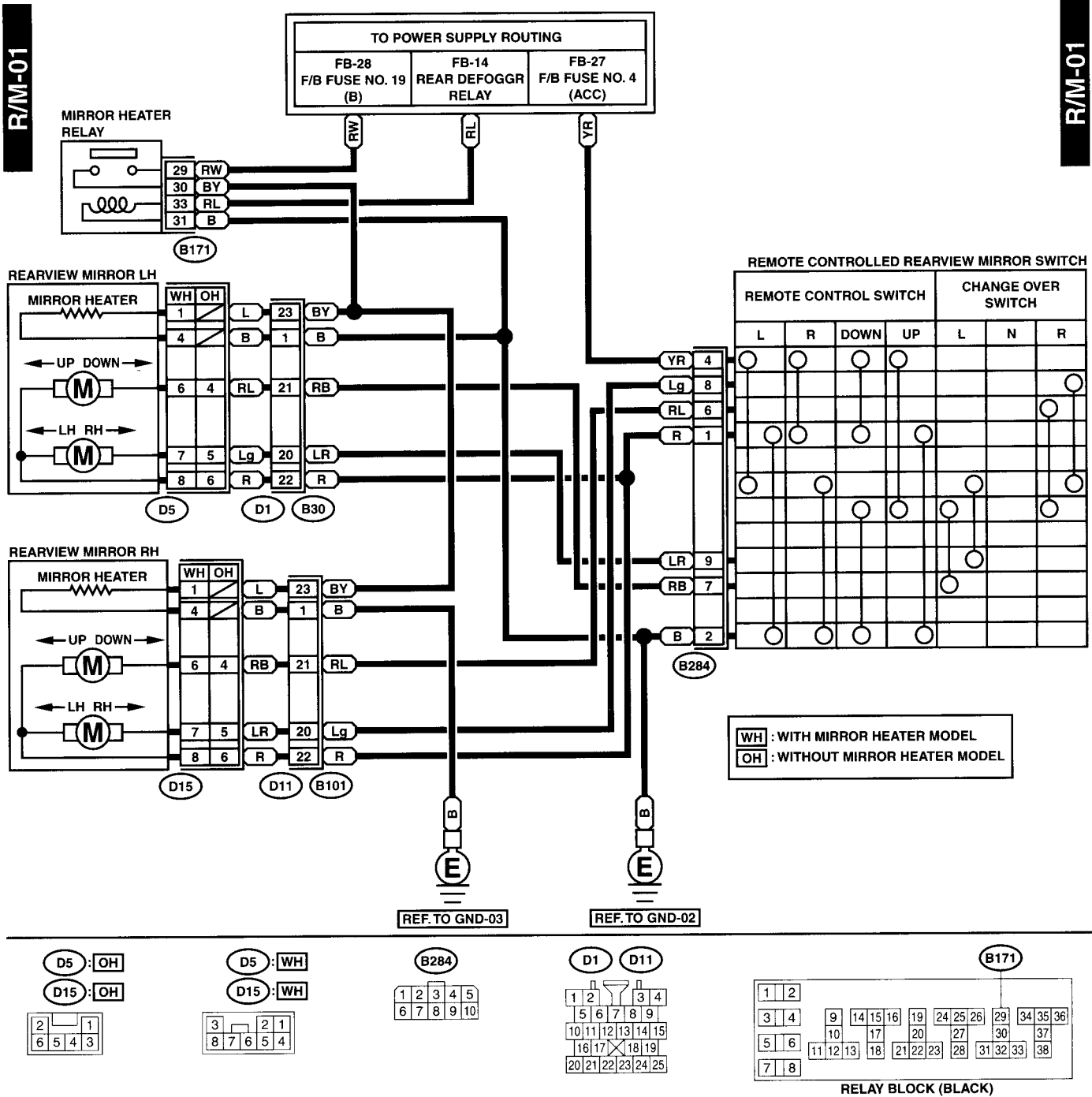

GU79-20

39. Seat Belt Warning and Key Warning System

A: SCHEMATIC

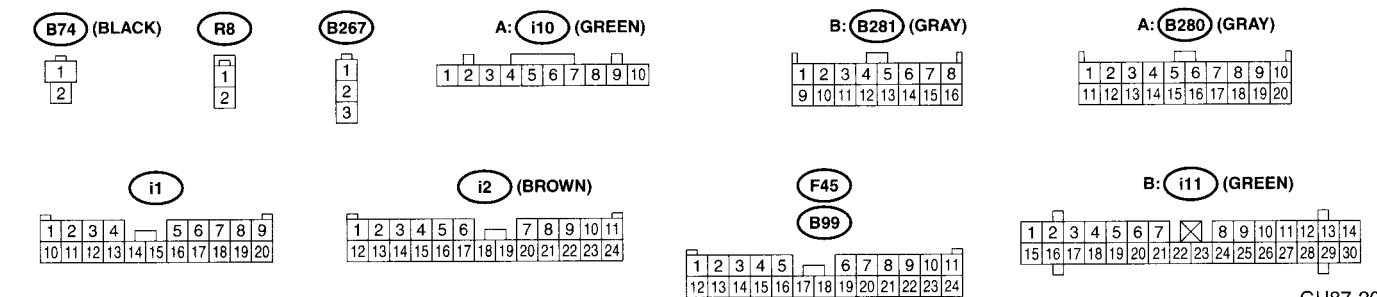
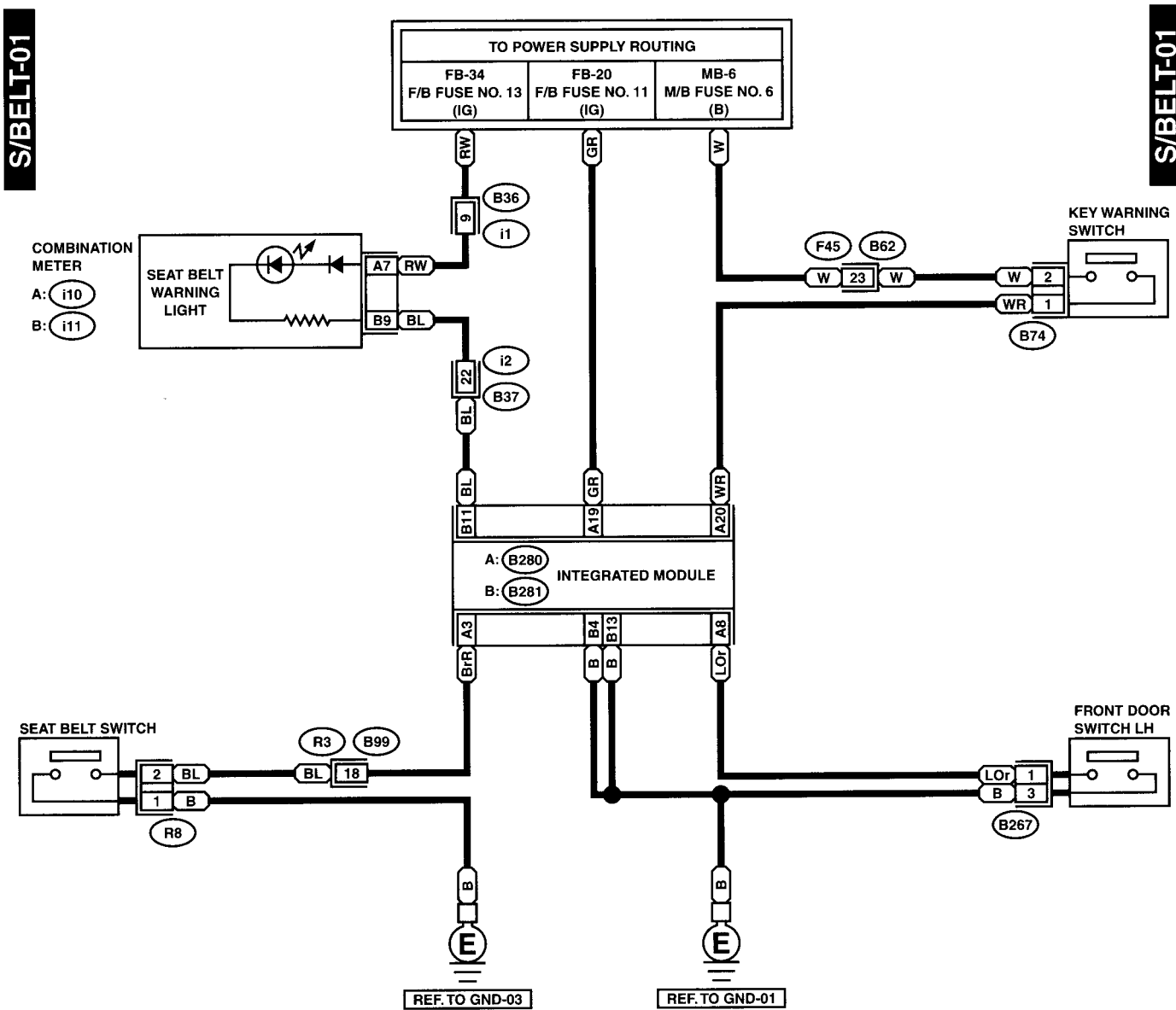

GU87-20

SEAT HEATER SYSTEM

WIRING SYSTEM

40. Seat Heater System

A: SCHEMATIC

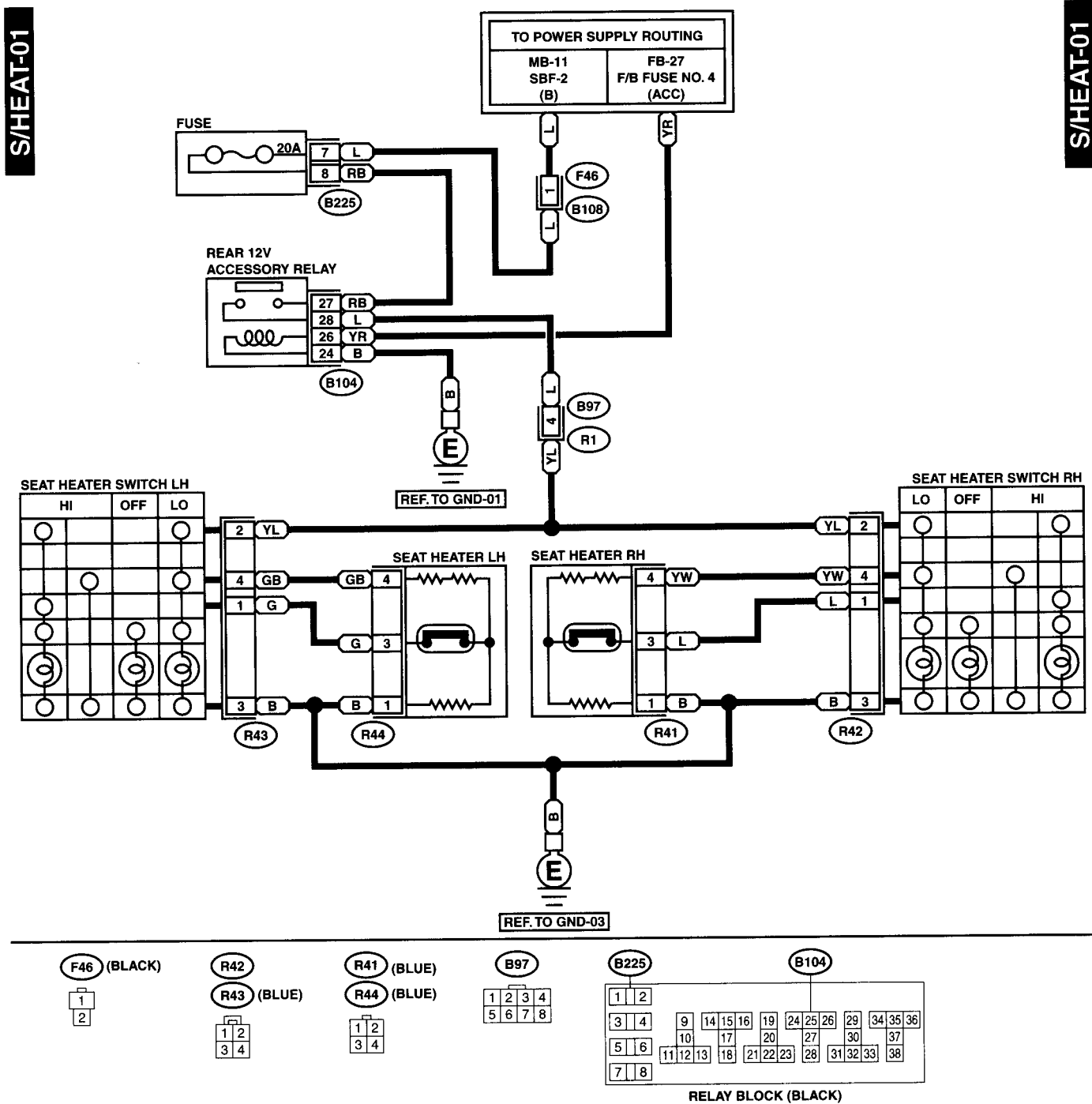

GU84-20

41. Security System

A: SCHEMATIC

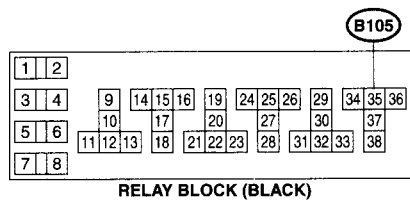
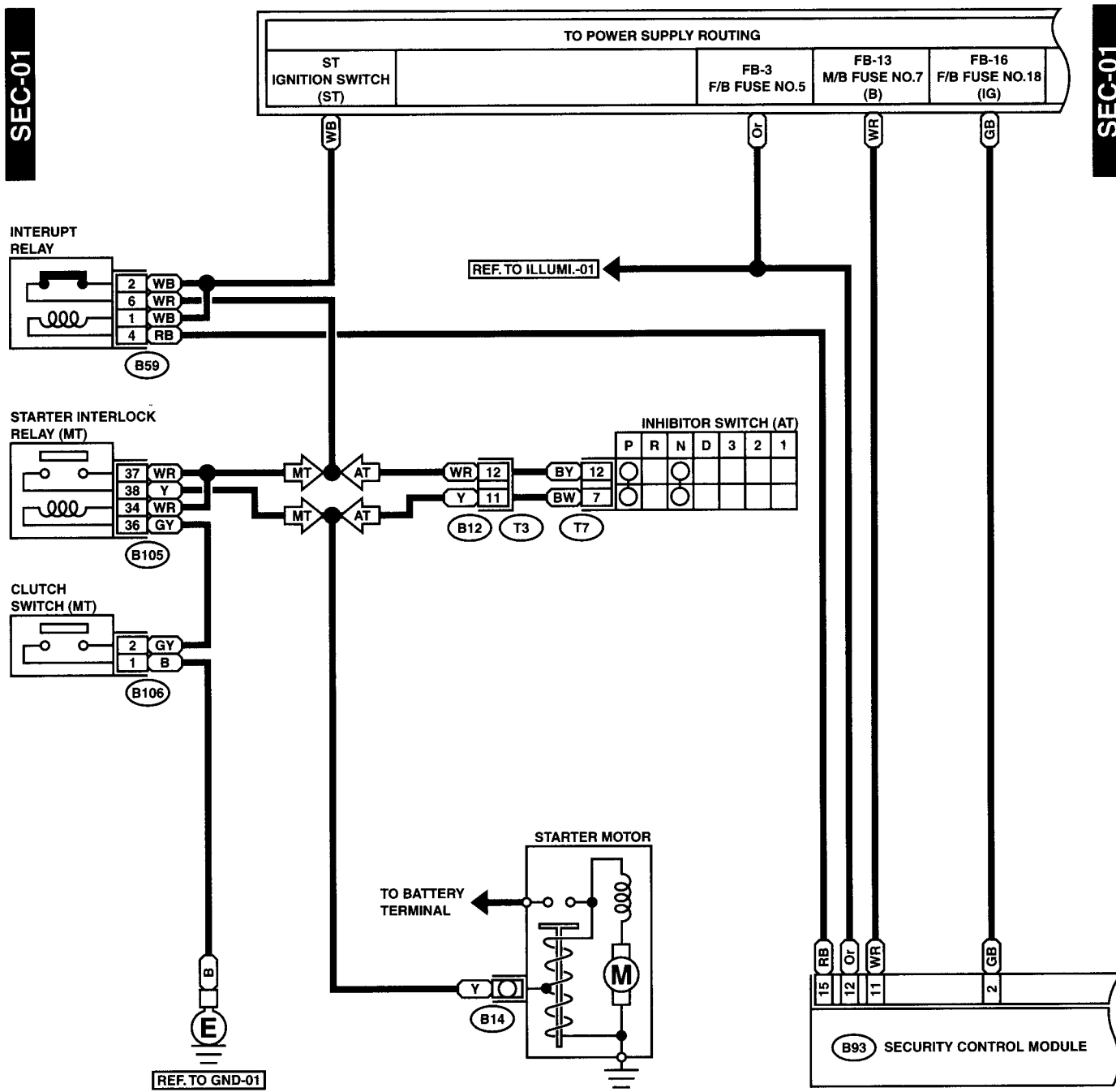

SECURITY SYSTEM

WIRING SYSTEM

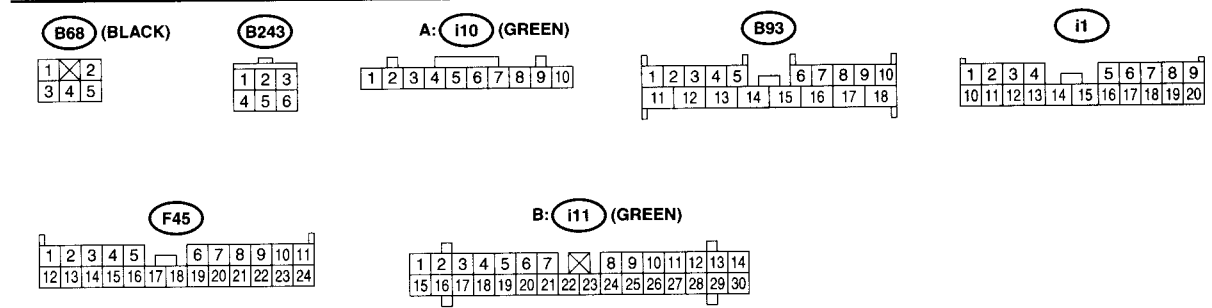
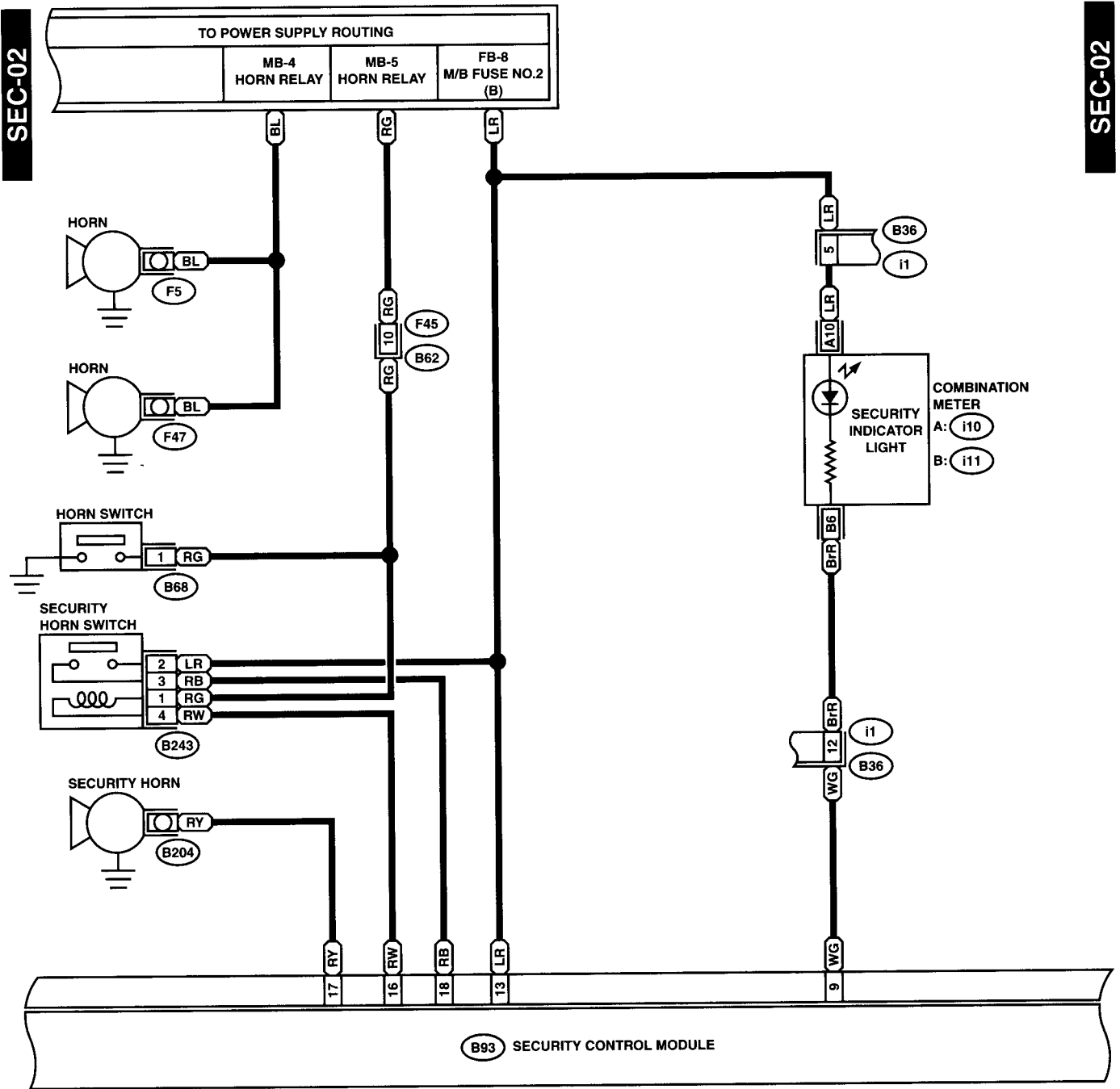

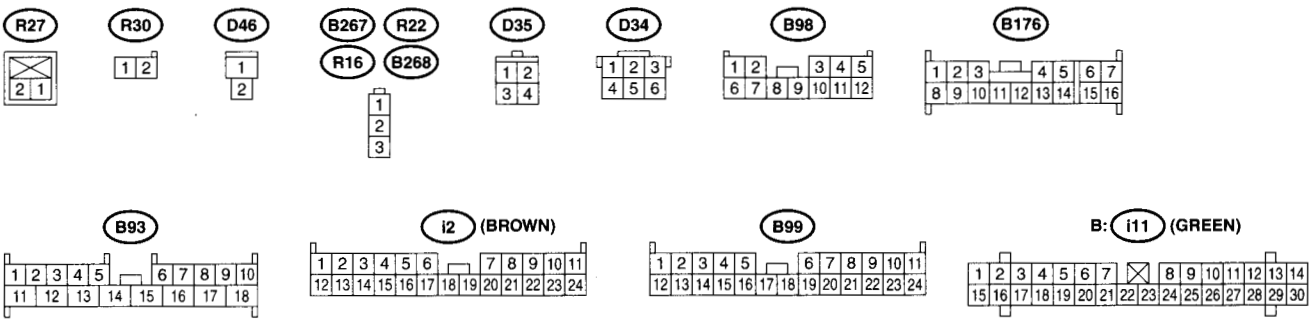
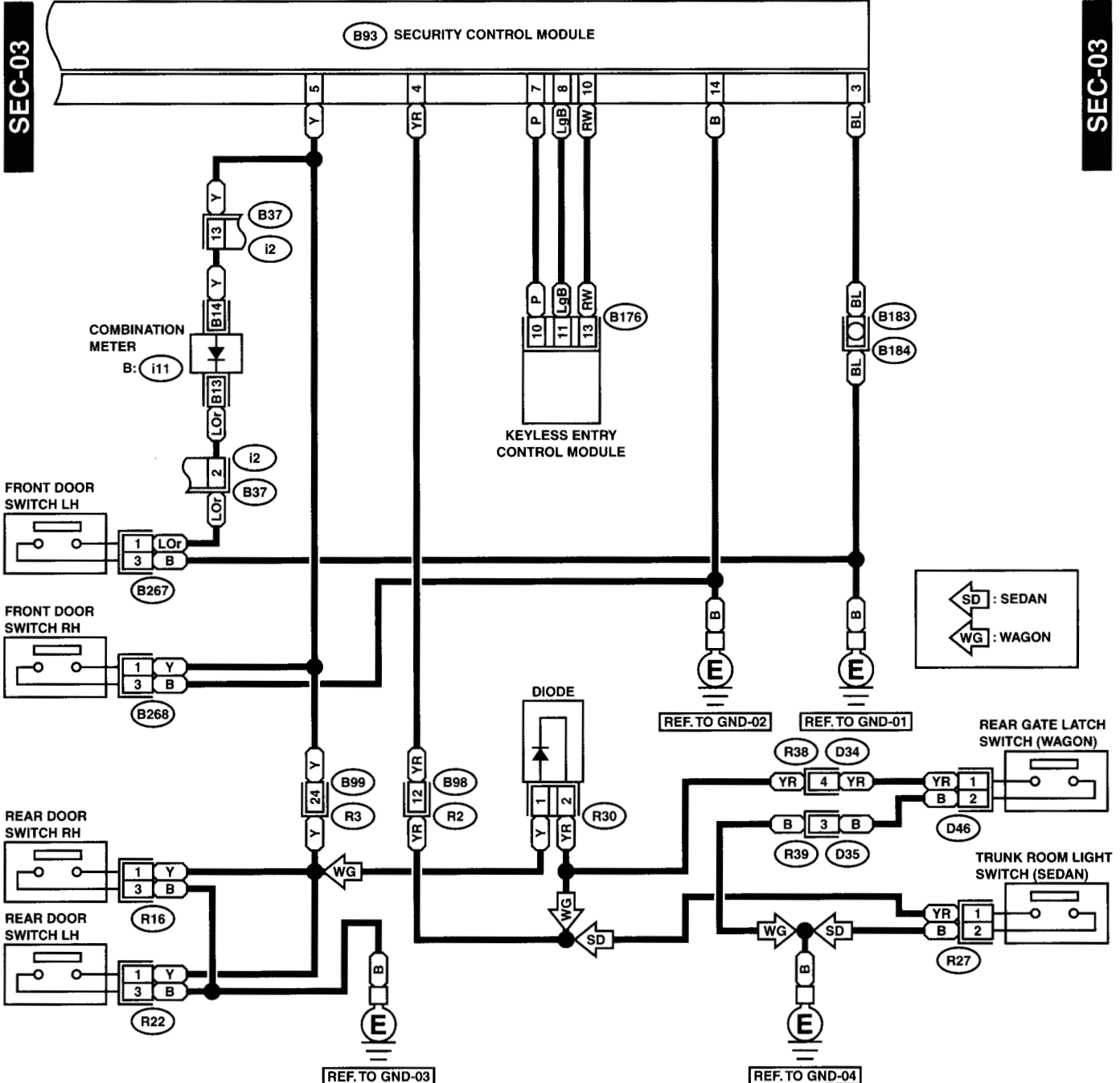

42.Starter System

A: SCHEMATIC

STARTER SYSTEM

WIRING SYSTEM

2. AT MODEL

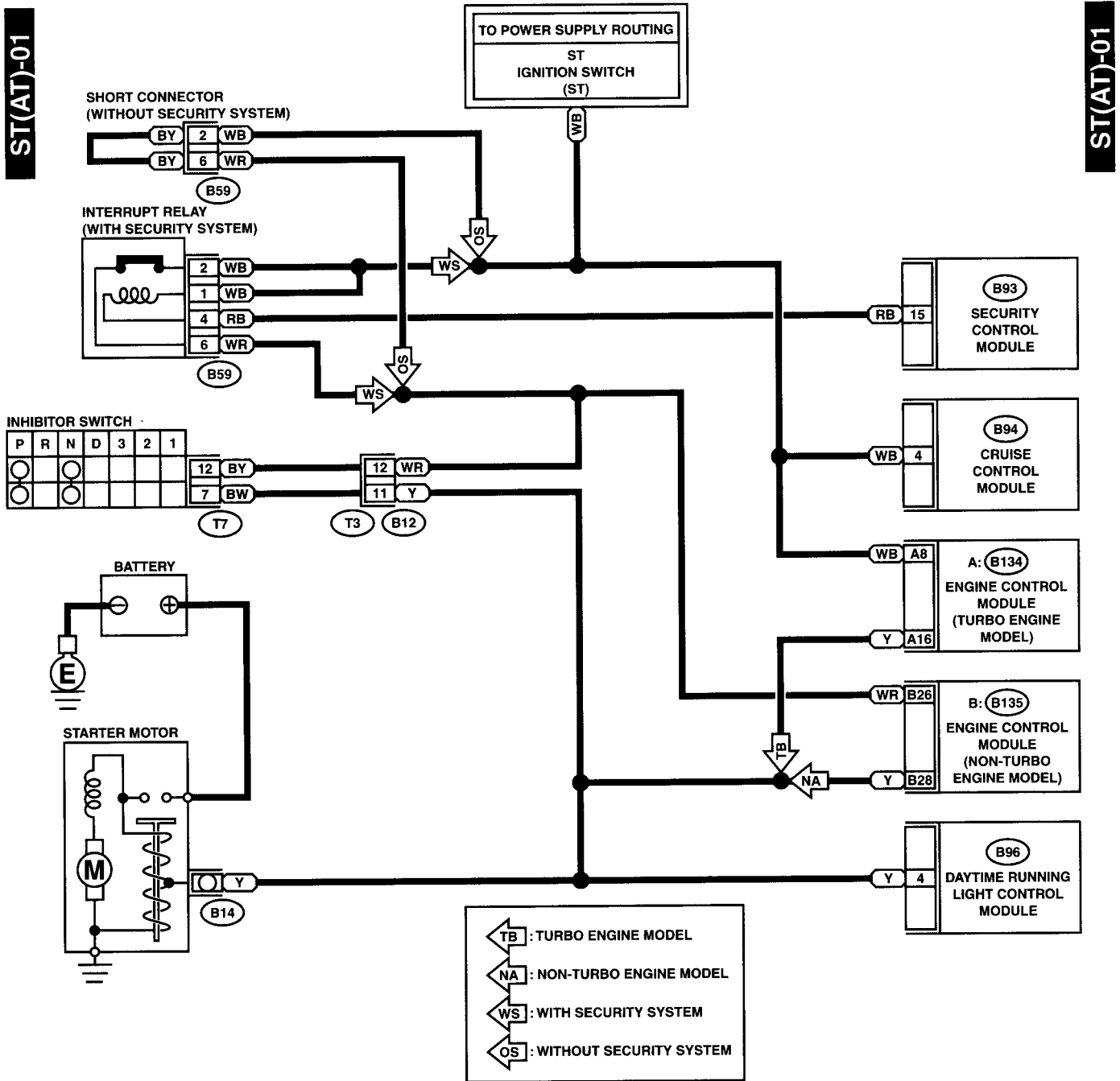

B59



B96

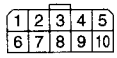

B12

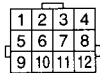

T7

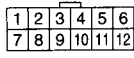

B93

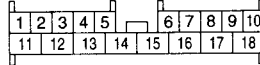

B94 (BLACK)

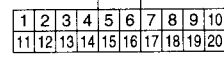

A: (B134)

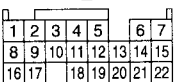

B: (B135)

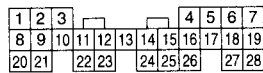

43. Wiper and Washer System (Front)

A: SCHEMATIC

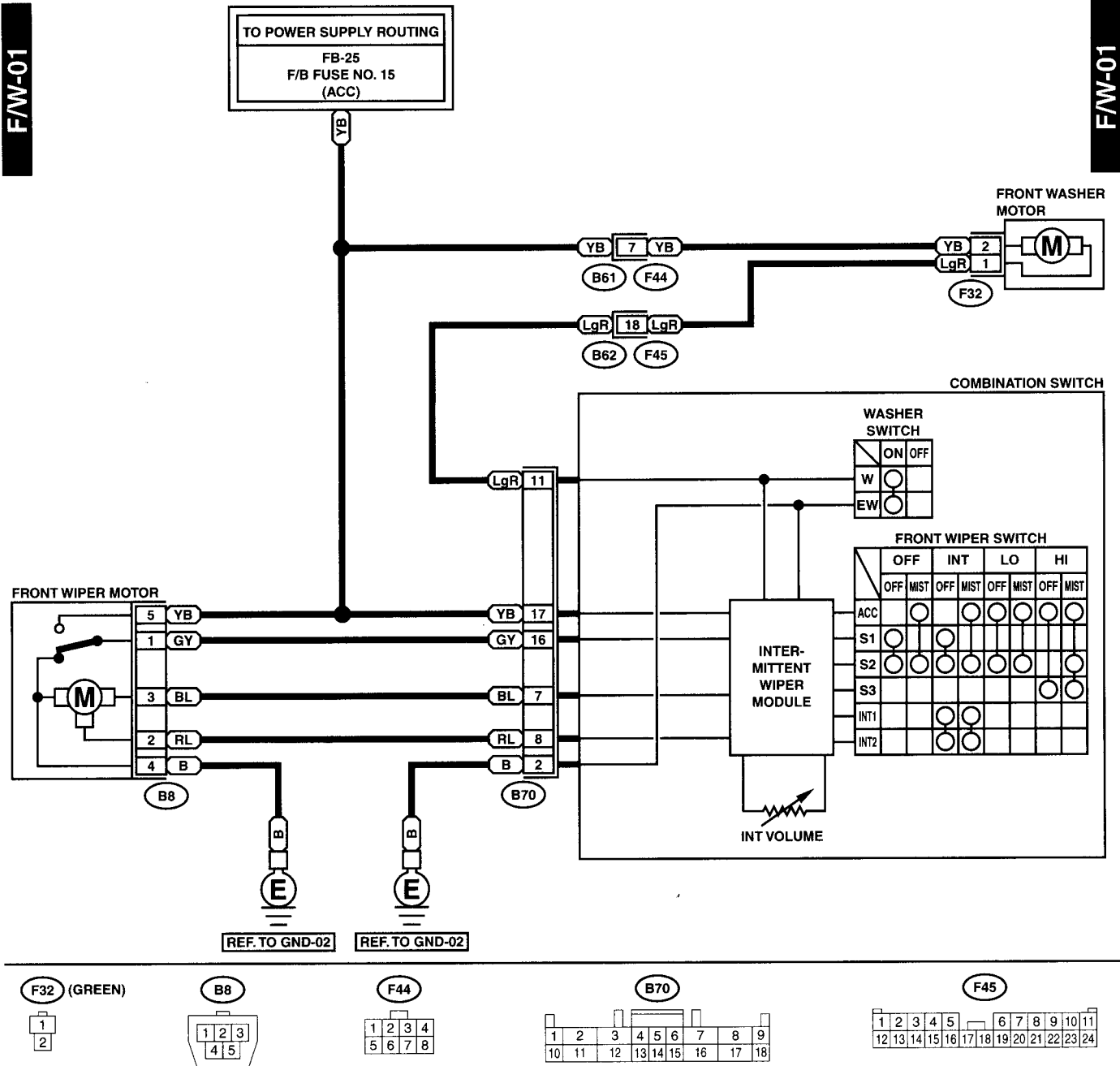

WIPER AND WASHER SYSTEM (REAR)

WIRING SYSTEM

44. Wiper and Washer System (Rear)

A: SCHEMATIC

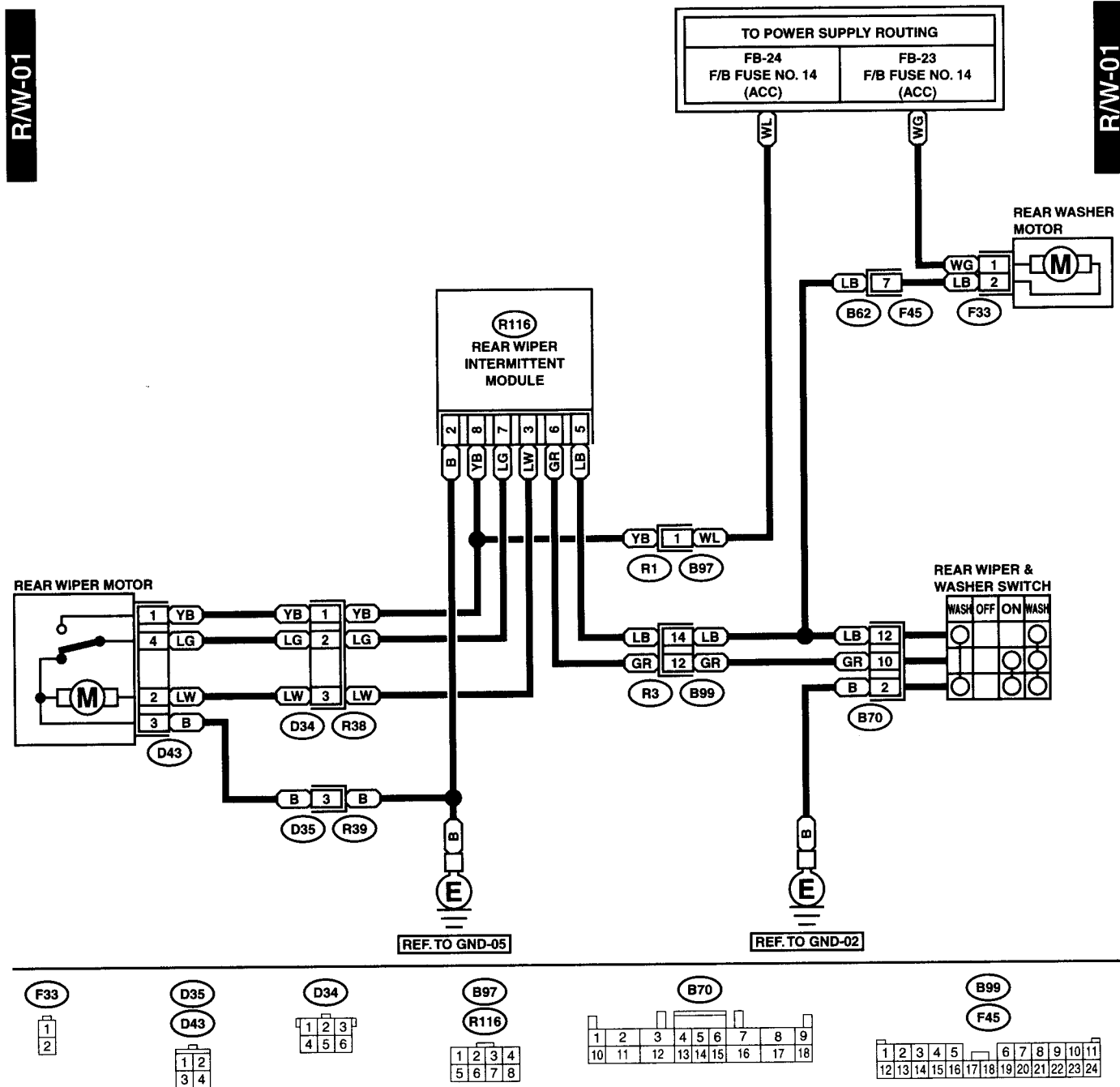

GU51-20

45.Overall Systems

A: LOCATION

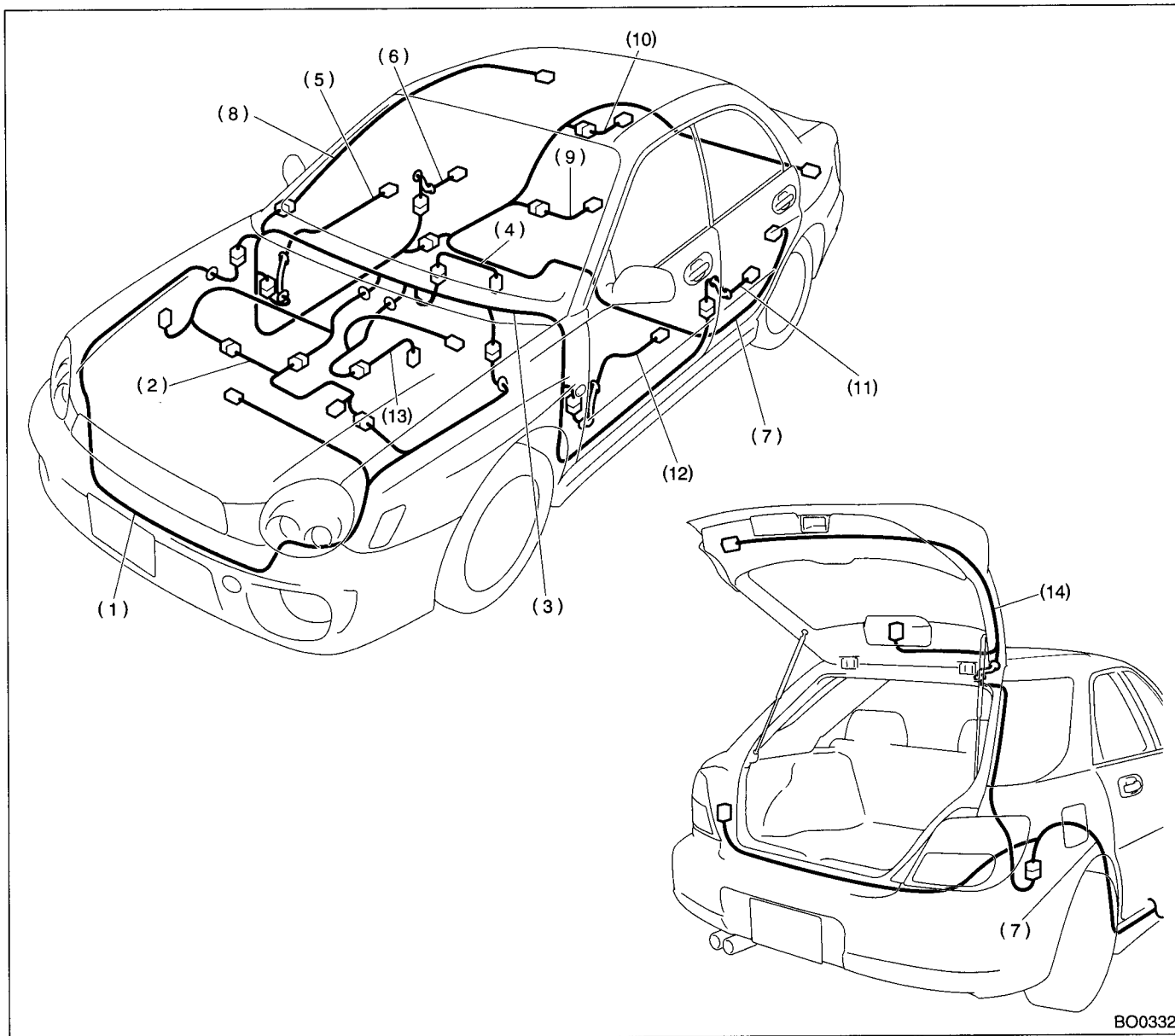

- | | | |
|-------------------------------------|-------------------------|-------------------------|
| (1) Front wiring harness | (6) Rear door cord RH | (11) Rear door cord LH |
| (2) Engine wiring harness | (7) Rear wiring harness | (12) Front door cord LH |
| (3) Bulkhead wiring harness | (8) Roof cord | (13) Transmission cord |
| (4) Instrument panel wiring harness | (9) Fuel tank cord | (14) Rear gate cord |
| (5) Front door cord RH | (10) Trunk lid cord | |

FRONT WIRING HARNESS

WIRING SYSTEM

46. Front Wiring Harness

A: LOCATION

Connector				Connecting to	
No.	Pole	Color	Area	No.	Name
F4	3	Gray	B-1		Front turn signal and clearance light RH
F5	1	★	C-2		Horn
F6	2	Black	C-1		Front fog light RH
F7	3	★	B-1		Headlight RH
F16	2	Black	C-1		Sub fan motor (Non-turbo engine model)
	3	Black	C-1		Sub fan motor (Turbo engine model)
F17	2	Black	D-3		Radiator main fan motor (Non-turbo engine model)
	3	Black	D-3		Radiator main fan motor (Turbo engine model)
F21	2	Black	D-4		Front fog light LH
F22	3	Gray	C-4		Front turn signal and clearance light LH
F23	3	★	C-4		Headlight LH
F24	3	Gray	B-3		A/C compressor
F25	1	★	B-2		Generator
F26	3	Green	B-2		
F27	4	★	A-3		A/C fuse (Relay holder)
F28	4	★	A-3		A/C sub fan relay (Relay holder-non-turbo engine model)
	4	★	A-3		A/C sub fan relay-1 (Relay holder-turbo engine model)
F29	4	★	A-4		A/C sub fan relay-2 (Relay holder-turbo engine model)
F30	4	★	A-4		Radiator main fan relay-2 (Relay holder-turbo engine model)
F31	4	★	A-3		A/C relay (Relay holder)
F32	2	Green	B-4		Front washer motor
F33	2	★	B-4		Rear washer motor
F34	4	★	B-4		SBF holder
F35	2	★	B-4		Main fuse box (M/B)
F36	3	★	B-5		
F37	6	Black	B-5		
F38	1	★	B-5		
F39	8	★	B-5		
F40	9	Brown	A-5		Fuse & relay box (F/B)
F41	7	Gray	B-5		

Connector				Connecting to	
No.	Pole	Color	Area	No.	Name
F44	8	★	A-5	B61	Bulkhead wiring harness
F45	24	★	A-5	B62	
F46	2	Black	B-5	B108	
F47	1	★	C-3		Horn
F49	31	★	B-2		ABS control module
F52	2	★	B-1		Side marker light RH
F53	2	★	C-4		Side marker light LH
F60	16	Brown	B-4	E3	Engine wiring harness (Turbo engine model)
F61	20	Black	C-4	E2	Engine wiring harness (Turbo engine model)
F62	8	Gray	B-1		Shield joint connector (ABS)
F66	4	★	A-4		Radiator main fan relay (Relay holder-non-turbo engine model)
	4	★	A-4		Radiator main fan relay-1 (Relay holder-turbo engine model)
F67	2	★	A-4		FWD switch (Relay holder)
F68	4	Black	B-5		Main fuse box (M/B)
F73	1	★	C-1		ABS motor ground
F74	20	★	A-2	B200	Bulkhead wiring harness (ABS)
F76	40	Gray	A-5	B209	Bulkhead wiring harness (SMJ-turbo engine model)
F78	2	Black	C-2		Ambient sensor
F79	2	Gray	B-4		A/C pressure switch
F94	2	Gray	B-4		ABS front sensor LH
F95	2	Gray	B-2		ABS front sensor RH

★: Non-colored

FRONT WIRING HARNESS

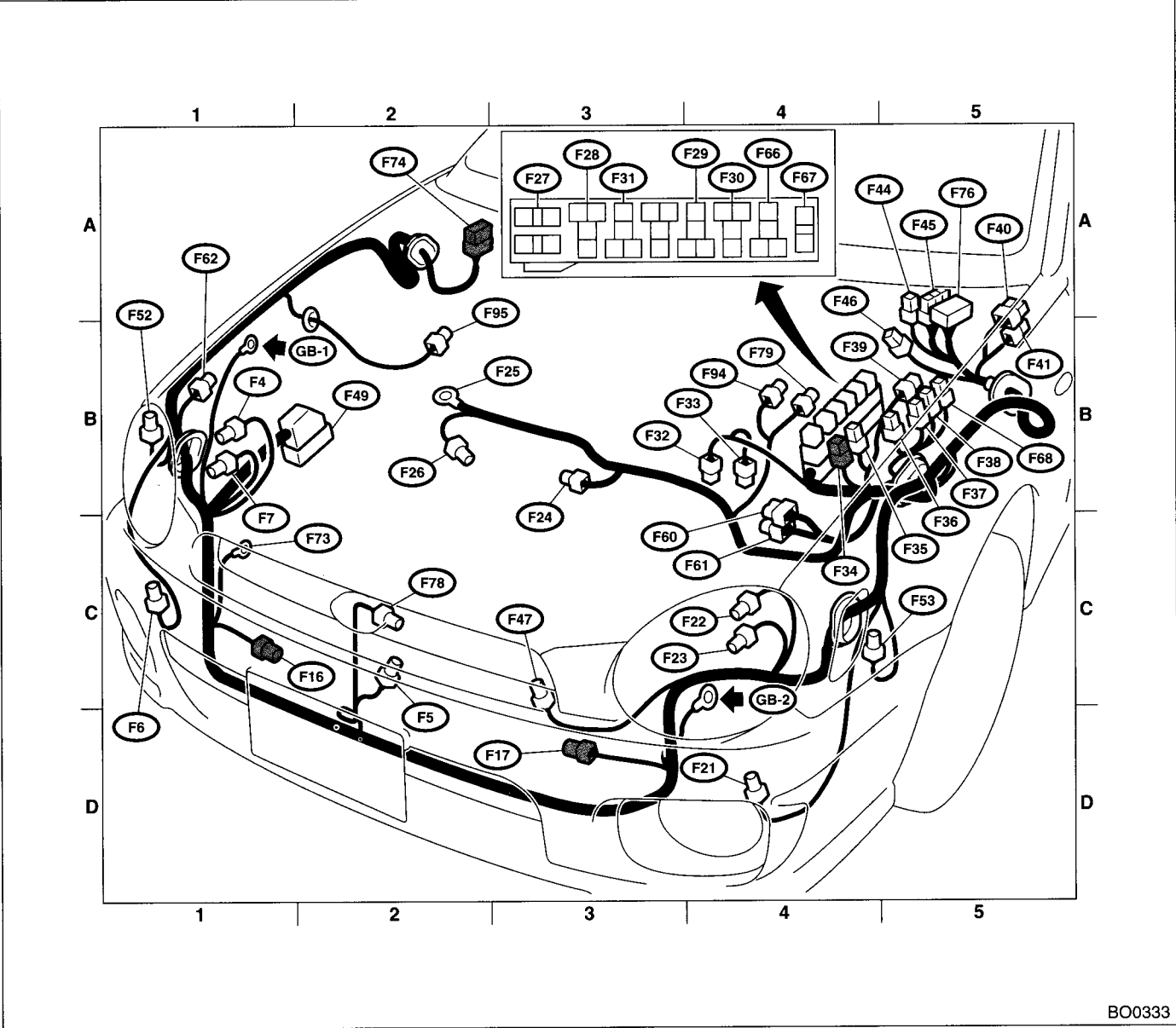

BO0333

BULKHEAD WIRING HARNESS (IN ENGINE ROOM)

WIRING SYSTEM

47. Bulkhead Wiring Harness (In Engine Room)

A: LOCATION

1. TURBO ENGINE MODEL

Connector				Connecting to	
No.	Pole	Color	Area	No.	Name
B3	5	Black	B-2		Mass air flow sensor
B5	2	Gray	B-2		Resistor (Daytime running light)
B7	6	Black	B-2		Cruise control actuator
B8	5	★	A-4		Front wiper motor
B11	20	Black	B-3	T4	Transmission (AT)
B12	12	★	B-3	T3	
B14	1	★	B-4		Starter (Magnet)
B16	2	Gray	B-4		Brake fluid level switch
B17	4	★	B-3		Vehicle speed sensor (MT)
B18	4	★	B-2		Front oxygen (A/F) sensor
B19	4	★	B-3		Rear oxygen sensor
B20	10	Light gray	B-2	E1	Engine wiring harness
B127	2	Blue	B-1		Wastegate solenoid
B128	4	★	B-3	T9	Transmission cord (MT)
B204	1	★	B-2		Security horn
B279	2	★	B-2		Exhaust gas temperature sensor

★: Non-colored

BULKHEAD WIRING HARNESS (IN ENGINE ROOM)

WIRING SYSTEM

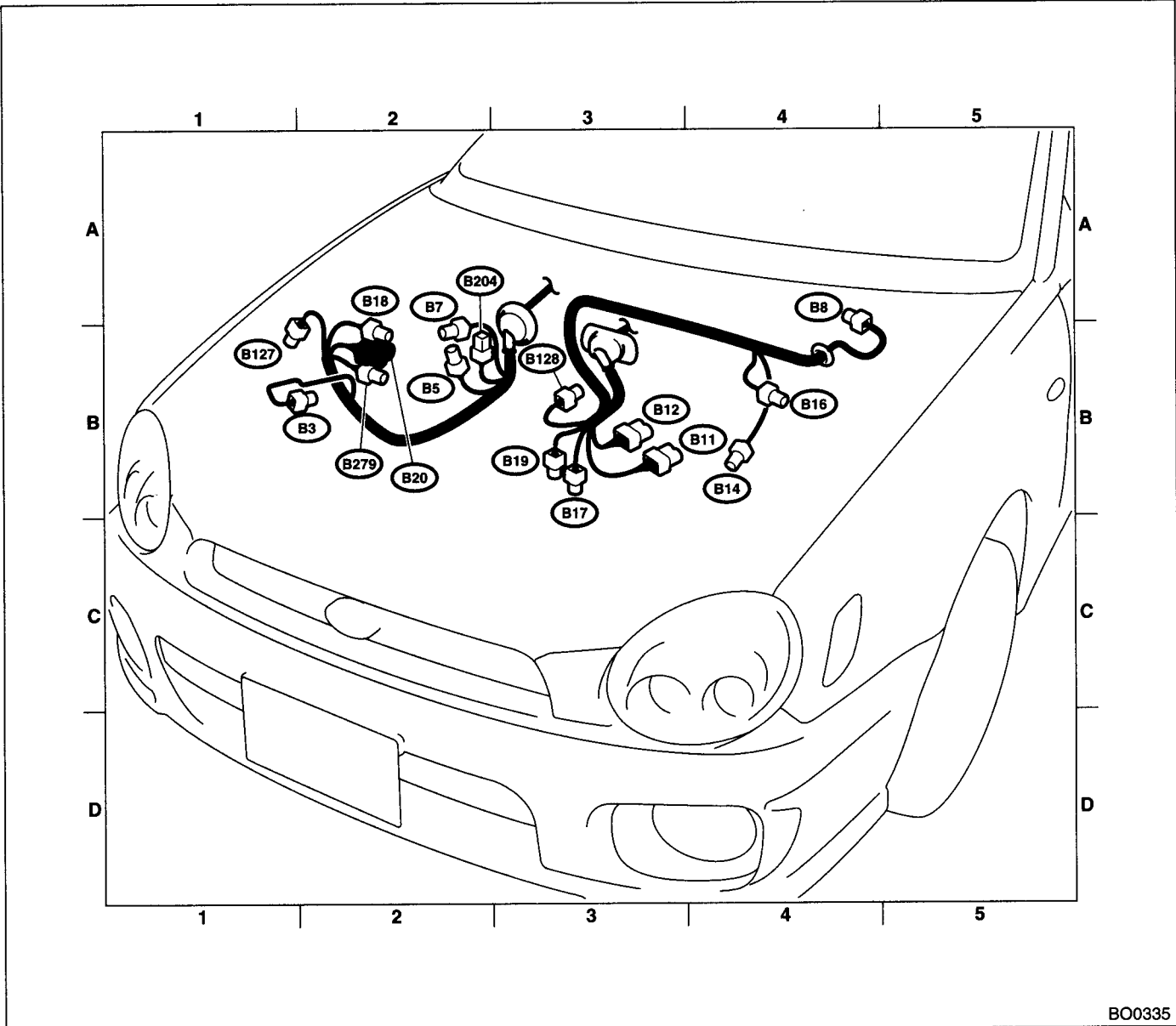

BO0335

BULKHEAD WIRING HARNESS (IN ENGINE ROOM)

WIRING SYSTEM

2. NON-TURBO ENGINE MODEL

Connector				Connecting to	
No.	Pole	Color	Area	No.	Name
B2	3	★	B-1		Atmospheric pressure sensor
B4	4	Gray	B-2		AT dropping resistor
B5	2	Gray	B-1		Resistor (Daytime running light)
B7	6	Black	B-2		Cruise control actuator
B8	5	★	A-4		Front wiper motor
B11	20	Black	B-3	T4	Transmission (AT)
B12	12	★	B-3	T3	
B14	1	★	B-4		Starter (Magnet)
B16	2	Gray	B-4		Brake fluid level switch
B17	3	★	B-3		Vehicle speed sensor (MT)
B20	10	★	B-3	E1	Oxygen sensor cord
B21	20	Gray	B-3	E2	Engine wiring harness
B22	16	Brown	B-3	E3	
B24	2	Gray	B-3	T1	Back-up light switch (MT)
B25	2	Brown	B-3	T2	Neutral position switch (MT)
B204	1	★	B-2		Security horn

★: Non-colored

BULKHEAD WIRING HARNESS (IN ENGINE ROOM)

WIRING SYSTEM

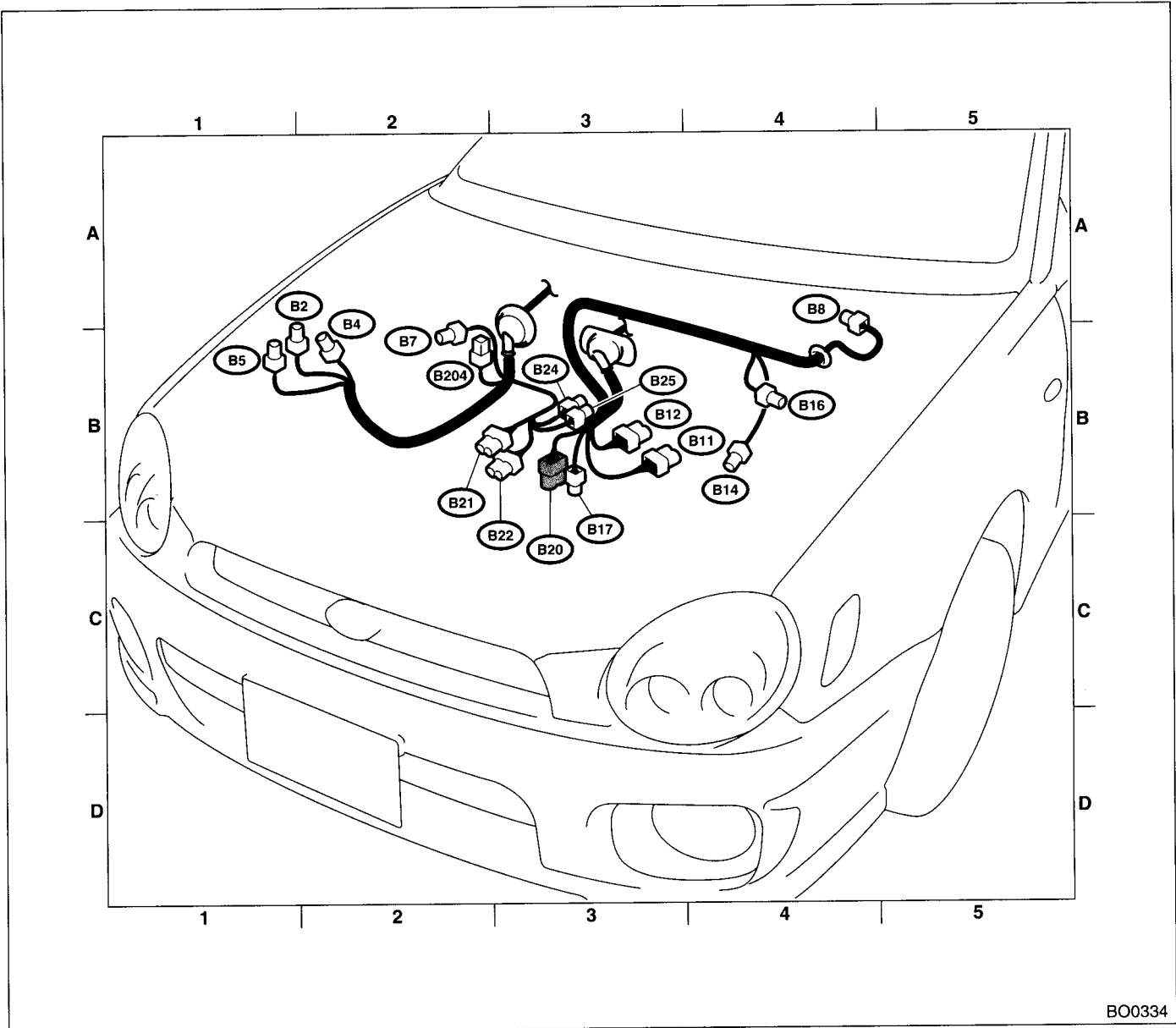

BO0334

BULKHEAD WIRING HARNESS (IN COMPARTMENT)

WIRING SYSTEM

48. Bulkhead Wiring Harness (In Compartment)

A: LOCATION

Connector				Connecting to	
No.	Pole	Color	Area	No.	Name
B30	25	★	D-1	D1	Front door cord LH
B31	6	Yellow	D-1	AB1	SRS (Airbag) harness
B32	3	Black	B-2		Turn & hazard module
B36	20	★	B-3	i1	Instrument panel wiring harness
B37	24	Brown	B-3	i2	
B40	16	Gray	C-3		Data link connector
B41	2	★	C-1		Power window circuit breaker
B42	5	★	C-2		Power window relay (Relay block)
B46	4	Green	B-5		Fuel pump relay
B47	6	Brown	B-5		Main relay
B48	5	★	C-2		Front fog light relay (Relay block)
B50	4	★	C-1		Blower fan motor relay
B51	8	Blue	C-1		Fuse & relay box (F/B)
B52	7	★	C-1		
B53	12	Black	C-2		Shield joint connector (AT-turbo engine model)
	8	★	C-2		Shield joint connector (AT-non-turbo engine model)
B54	24	★	B-2		Transmission control module
B55	24	Gray	B-2		
B56	24	Green	B-2		Transmission control module (Turbo engine model)
B59	6	★	B-3		Interrupt relay (Security)
B61	8	★	B-2	F44	Front wiring harness
B62	24	★	B-2	F45	
B64	2	Black	B-2		Stop light switch (Without cruise control model)
B65	4	Black	B-2		Stop light and brake switch (With cruise control model)
B68	5	Black	C-3		Cruise control sub switch
B69	4	★	C-3		Combination switch
B70	18	★	C-3		
B71	17	★	C-3		
B72	4	Blue	B-3		Ignition switch
B73	2	★	B-3		Key lock solenoid (AT)
B74	2	Black	C-3		Key warning switch
B75	2	Green	C-2	B76	Test mode connector
B76	2	Green	C-2	B75	
B79	14	Gray	C-3		Check connector

Connector				Connecting to	
No.	Pole	Color	Area	No.	Name
B81	1 × 2	★	C-2		Diagnosis terminal (Ground)
B82	6	Black	C-2		Diagnosis connector
B83	8	★	C-5		Shield & sensor ground joint connector (E/G-turbo engine model)
	6	★	C-5		Shield & sensor ground joint connector (E/G-non-turbo engine model)
B84	17	★	C-4		Engine control module (Turbo engine model)
B86	4	Brown	B-4		Blower fan motor resistor
B87	2	★	B-4		Blower fan motor
B88	4	Brown	B-4		Evaporation thermostat
B90	6	★	A-5	R50	Roof cord
B93	18	★	B-4		Security control module
B94	20	Black	C-1		Cruise control module
B95	2	★	B-4		Diode (Daytime running light)
B96	10	★	B-5		Daytime running light control module
B101	25	★	C-5	D11	Front door cord RH
B102	5	★	B-5		Daytime running light relay
B103	4	★	B-5		Hi-beam relay (Daytime running light)
B104	5	★	C-2		Rear 12V accessory relay (Relay block)
B105	5	★	C-2		Starter interlock relay (MT-relay block)
B106	2	★	B-2		Clutch switch (MT)
B107	2	Blue	B-2		Clutch switch (MT-cruise control)
B108	2	Black	B-1	F46	Front wiring harness
B112	2	★	B-3		Diode (Front fog light)
B116	6	★	D-4		AT Select lever
B118	2	★	B-4		Compact disc player illumination light
B119	4	★	C-4		Front accessory power supply socket
B120	14	★	B-4		Radio
B121	1	★	B-4		Audio bracket earth

★: Non-colored

BULKHEAD WIRING HARNESS (IN COMPARTMENT)

WIRING SYSTEM

Connector				Connecting to	
No.	Pole	Color	Area	No.	Name
B122	6	★	C-5		Sensor ground joint connector (E/G-non-turbo engine model)
B125	1	Green	B-5	B126	Line end connector
B126	1	Green	B-5	B125	
B134	22	★	B-4		Engine control module (Turbo engine model)
	35	★	B-4		Engine control module (Non-turbo engine model)
B135	28	★	B-4		Engine control module
B136	24	★	B-4		Engine control module (Turbo engine model)
	30	★	B-4		Engine control module (Non-turbo engine model)
B137	31	★	C-4		Engine control module (Turbo engine model)
B152	12	★	C-1		Fuse & relay box (F/B)
B157	5	★	C-2		Ignition relay (Relay block)
B158	10	Gray	C-1		Fuse & relay box (F/B)
B160	6	Gray	C-1		Front fog light switch
B161	6	Brown	C-1		Cruise control main switch
B168	10	★	C-4		Mode control panel
B169	6	★	C-4		Blower fan switch
B171	5	★	C-2		Mirror heater relay (Relay block)
B176	16	★	C-1		Keyless entry control module
B183	1	★	D-1	B184	Joint connector (Security)
B184	1	★	D-1	B183	
B200	20	★	B-5	F74	Front wiring harness (ABS)
B208	2	Black	B-5		Glove box illumination light
B209	40	Gray	B-1	F76	Front wiring harness (SMJ-turbo engine model)
B225	8	★	C-2		Fuse (Relay block)
B243	6	★	B-3		Security horn relay
B250	3	★	C-2		Flash memory connector
B264	4	Red	C-1		ABS relay
B271	12	Blue	C-1		Fuse & relay box (F/B)
B280	20	Gray	B-3		Integrated module
B281	16	Gray	B-3		
B284	10	★	D-5		Remote controlled rearview mirror switch
B292	3	★	D-5		ABS G sensor

★: Non-colored

BULKHEAD WIRING HARNESS (IN COMPARTMENT)

WIRING SYSTEM

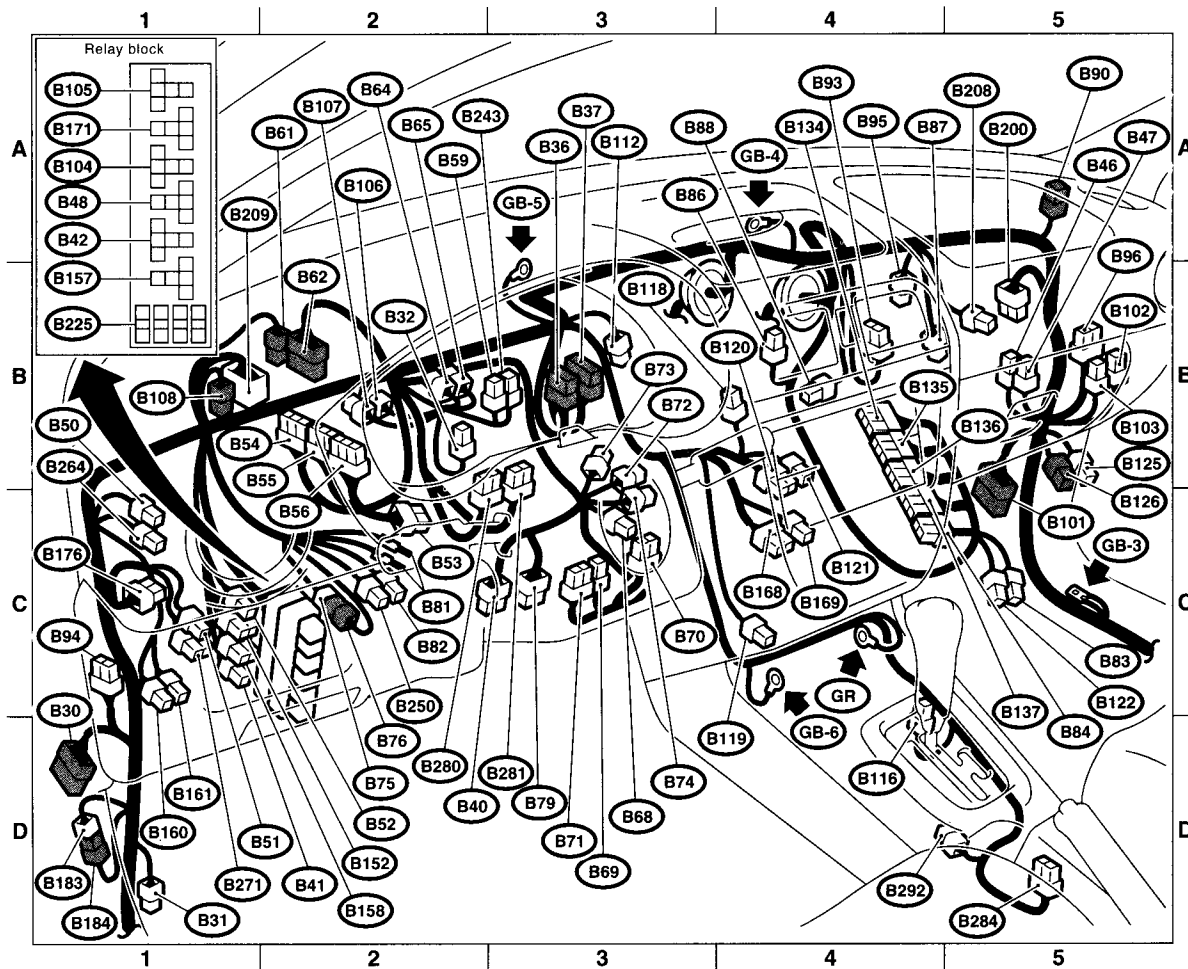

BO0336

49.Engine Wiring Harness and Transmission Cord

A: LOCATION

1. TURBO ENGINE MODEL

Connector				Connecting to	
No.	Pole	Color	Area	No.	Name
E1	10	Light gray	A-1	B20	Bulkhead wiring harness
E2	20	Black	C-3	F61	Front wiring harness
E3	16	Brown	C-3	F60	
E4	2	Black	B-2		Purge control solenoid valve
E5	2	Dark gray	B-1		Fuel injector No.1
E6	2	Dark gray	A-2		Fuel injector No.3
E7	3	Black	B-2		Idle air control solenoid valve
E8	3	Light gray	B-2		Engine coolant temperature sensor and thermometer
E10	2	Light gray	B-1		Crank shaft position sensor
E11	1	★	B-2		Oil pressure switch
E13	3	Black	B-2		Throttle position sensor
E14	2	Gray	B-3		Knock sensor
E15	2	Light gray	C-3		Camshaft position sensor
E16	2	Dark gray	C-3		Fuel injector No.2
E17	2	Dark gray	C-3		Fuel injector No.4
E19	1	★	B-2		Power steering oil pressure switch
E21	3	Black	B-2		Pressure sensor
E31	3	★	B-1		Ignition coil No.1
E32	3	★	C-3		Ignition coil No.2
E33	3	Black	B-2		Ignition coil No.3
E34	3	Black	C-4		Ignition coil No.4
E50	3	Black	C-2		TGV angle sensor LH
E51	2	Black	B-3		TGV LH
E54	3	Black	B-2		TGV angle sensor RH
E55	2	Black	B-1		TGV RH

★:Non-colored

Connector				Connecting to	
No.	Pole	Color	Area	No.	Name
T3	12	★	A-4	B12	Bulkhead wiring harness (AT)
T4	20	Black	A-4	B11	
T7	12	★	A-5		Inhibitor switch (AT)
T9	4	★	D-4	B128	Bulkhead wiring harness (MT)

★:Non-colored

ENGINE WIRING HARNESS AND TRANSMISSION CORD

WIRING SYSTEM

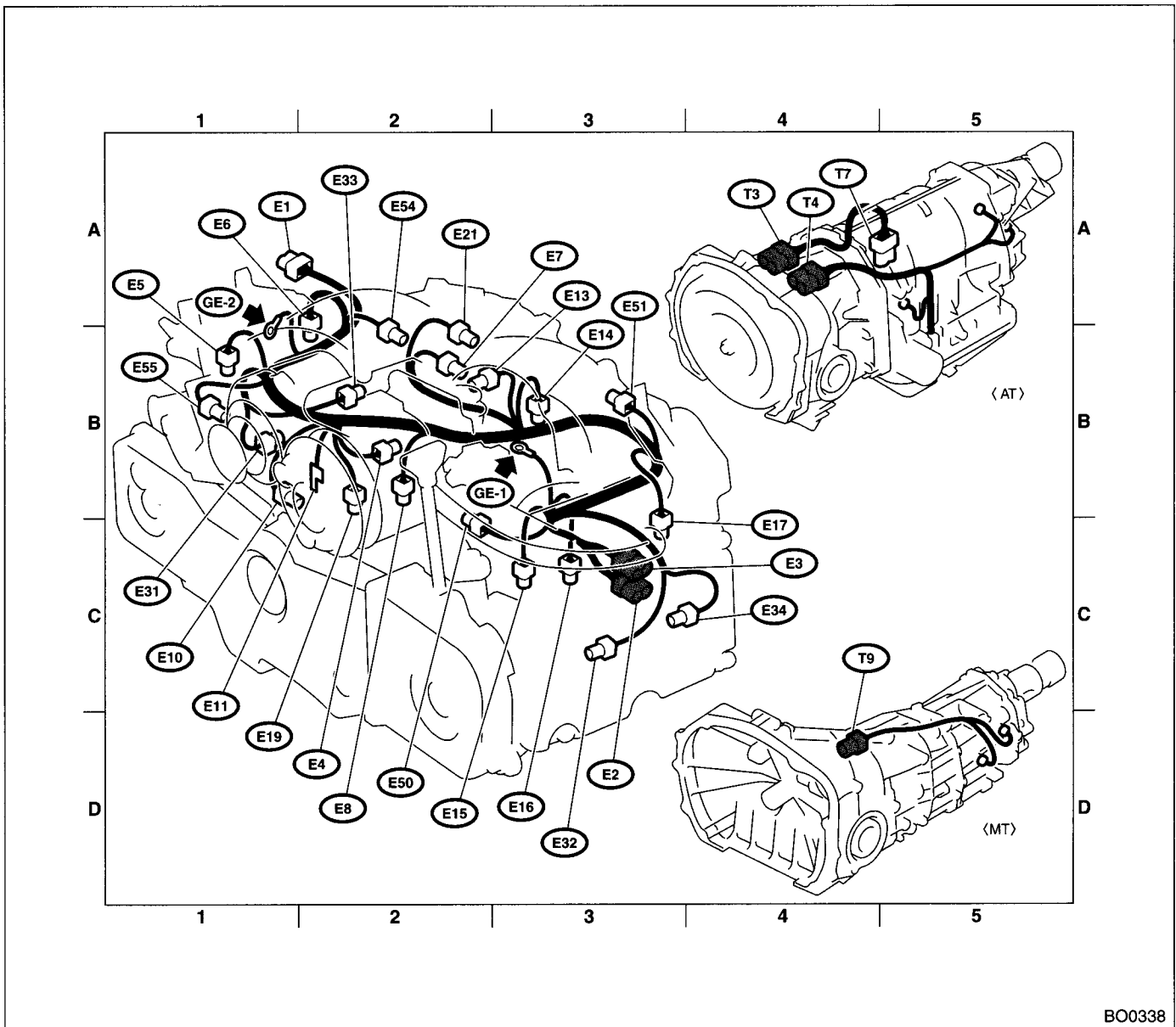

ENGINE WIRING HARNESS AND TRANSMISSION CORD

WIRING SYSTEM

2. NON-TURBO ENGINE MODEL

Connector				Connecting to	
No.	Pole	Color	Area	No.	Name
E2	20	Light gray	A-3	B21	Bulkhead wiring harness
E3	16	Brown	A-3	B22	
E4	2	Black	A-2		Purge control solenoid valve
E5	2	Light gray	B-1		Fuel injector No.1
E6	2	Light gray	A-2		Fuel injector No.3
E7	6	Black	B-1		Idle air control solenoid valve
E8	3	Light gray	B-2		Engine coolant temperature sensor and thermometer
E10	2	Light gray	B-2		Crank shaft position sensor
E11	1	★	B-2		Oil pressure switch
E12	4	Dark gray	B-2		Ignition coil and ignitor
E13	4	Dark brown	B-2		Throttle position sensor
E14	2	★	B-3		Knock sensor
E15	2	Black	C-3		Camshaft position sensor
E16	2	Light gray	C-3		Fuel injector No.2
E17	2	Light gray	B-3		Fuel injector No.4
E19	1	★	B-1		Power steering oil pressure switch
E20	4	Black	A-2		Pressure sensor and intake air temperature sensor
E42	2	Purple	B-2		Air assist injector solenoid valve

★:Non-colored

Connector				Connecting to	
No.	Pole	Color	Area	No.	Name
T1	2	Gray	D-5	B24	Bulkhead wiring harness (MT)
T2	2	Brown	D-4	B25	
T3	12	★	A-4	B12	Bulkhead wiring harness (AT)
T4	20	Black	A-4	B11	
T7	12	★	A-5		Inhibitor switch (AT)

★:Non-colored

ENGINE WIRING HARNESS AND TRANSMISSION CORD

WIRING SYSTEM

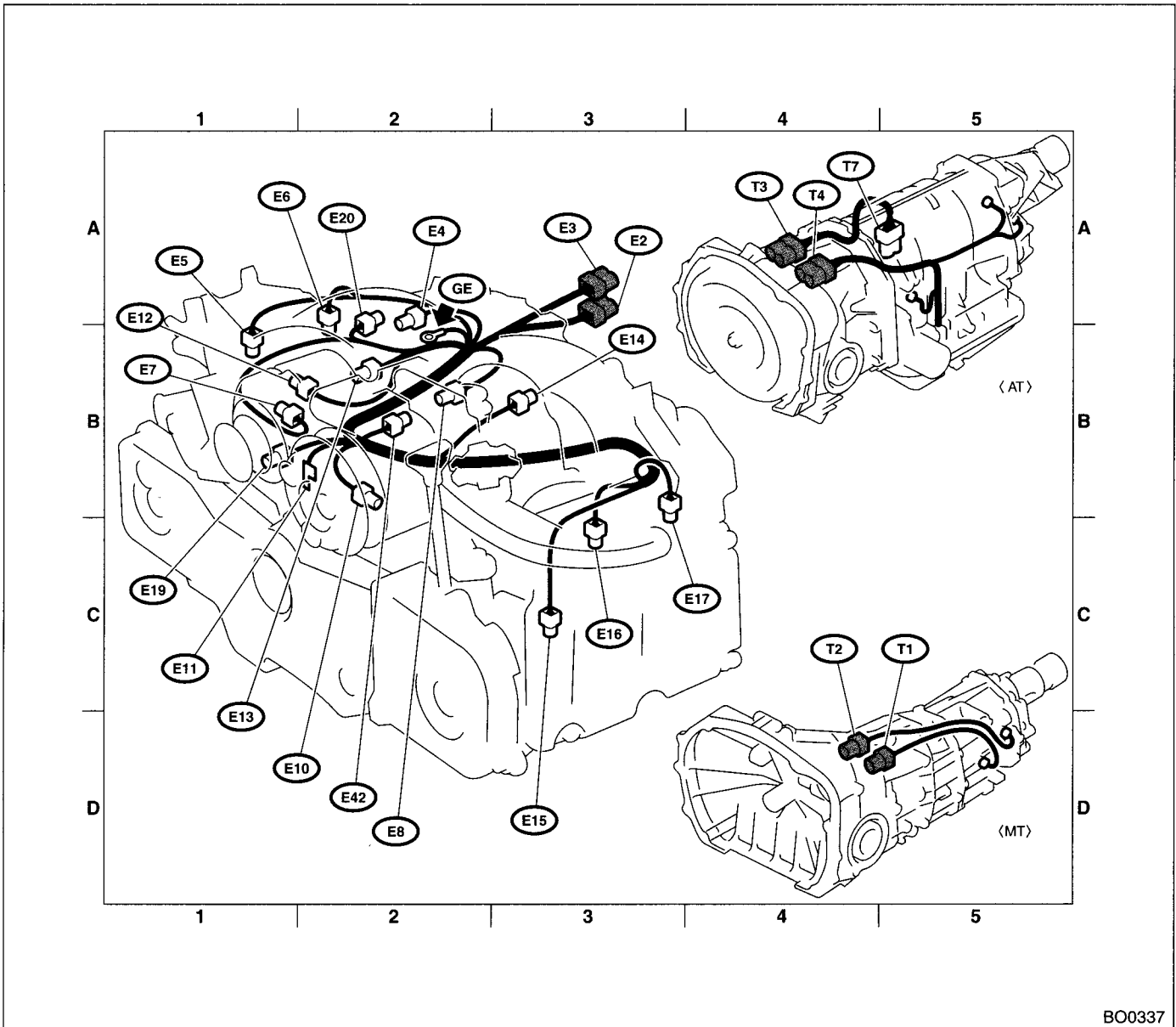

BO0337

50. Instrument Panel Wiring Harness

A: LOCATION

Connector				Connecting to	
No.	Pole	Color	Area	No.	Name
i1	20	★	B-3	B36	Bulkhead wiring harness
i2	24	Brown	B-3	B37	
i10	10	Green	B-3		Combination meter
i11	30	Green	B-2		
i12	14	Green	B-2		
i22	8	★	B-4		Hazard switch
i59	4	★	A-3		Clock

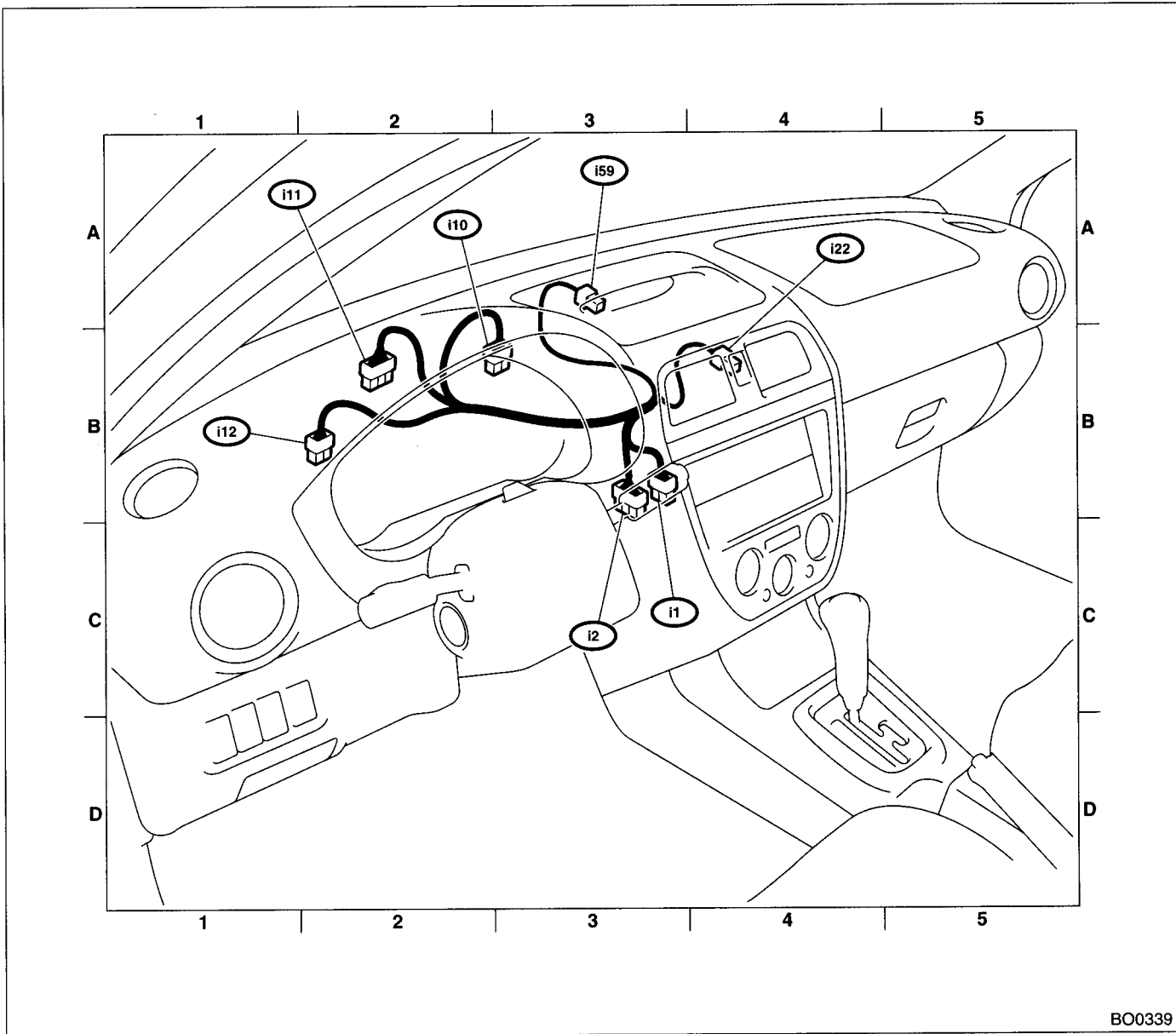

BO0339

REAR WIRING HARNESS, BULKHEAD WIRING HARNESS, ROOF CORD AND FUEL TANK CORD

WIRING SYSTEM

51. Rear Wiring Harness, Bulkhead wiring Harness, Roof Cord and Fuel Tank Cord

A: LOCATION

Connector				Connecting to	
No.	Pole	Color	Area	No.	Name
R1	8	★	B-2	B97	Bulkhead wiring harness
R2	12	★	B-1	B98	
R3	24	★	B-2	B99	
R4	1	★	B-3		Parking brake switch
R8	2	★	C-4		Seat belt switch
R15	12	★	B-3	R57	Fuel tank cord
R22	3	★	B-5		Rear door switch LH
R41	4	Blue	B-2		Seat heater RH
R42	4	★	B-3		Seat heater switch RH
R43	4	Blue	B-3		Seat heater switch LH
R44	4	Blue	C-4		Seat heater LH
R46	2	★	B-3	R67	Fuel tank cord
R72	2	★	A-3		Rear ABS sensor RH
R73	2	★	B-5		Rear ABS sensor LH

★: Non-colored

Connector				Connecting to	
No.	Pole	Color	Area	No.	Name
B97	8	★	B-2	R1	Rear wiring harness
B98	12	★	B-1	R2	
B99	24	★	B-2	R3	
B265	4	★	A-2	D27	Rear door cord RH
B266	3	★	A-2	D28	
B267	3	★	C-4		Front door switch LH
B268	3	★	A-2		Front door switch RH
B269	4	★	B-5	D21	Rear door cord LH
B270	3	★	B-4	D22	

★: Non-colored

Connector				Connecting to	
No.	Pole	Color	Area	No.	Name
R50	6	★	B-1	B90	Bulkhead wiring harness
R52	3	★	A-3		Room light
R55	1	Gray	A-2		Not used
R56	2	★	A-3		Spot light
R139	3	★	A-2		Compass mirror

★: Non-colored

REAR WIRING HARNESS, BULKHEAD WIRING HARNESS, ROOF CORD AND FUEL TANK CORD

WIRING SYSTEM

Connector				Connecting to	
No.	Pole	Color	Area	No.	Name
R47	3	★	B-4		Fuel tank pressure sensor
R57	12	★	B-3	R15	Rear wiring harness
R58	6	★	A-4		Fuel pump assembly
R59	2	★	B-4		Fuel sub level sensor
R67	2	★	B-3	R46	Rear wiring harness
R68	2	★	A-4		Pressure control solenoid valve
R69	2	★	A-4		Drain valve

★: Non-colored

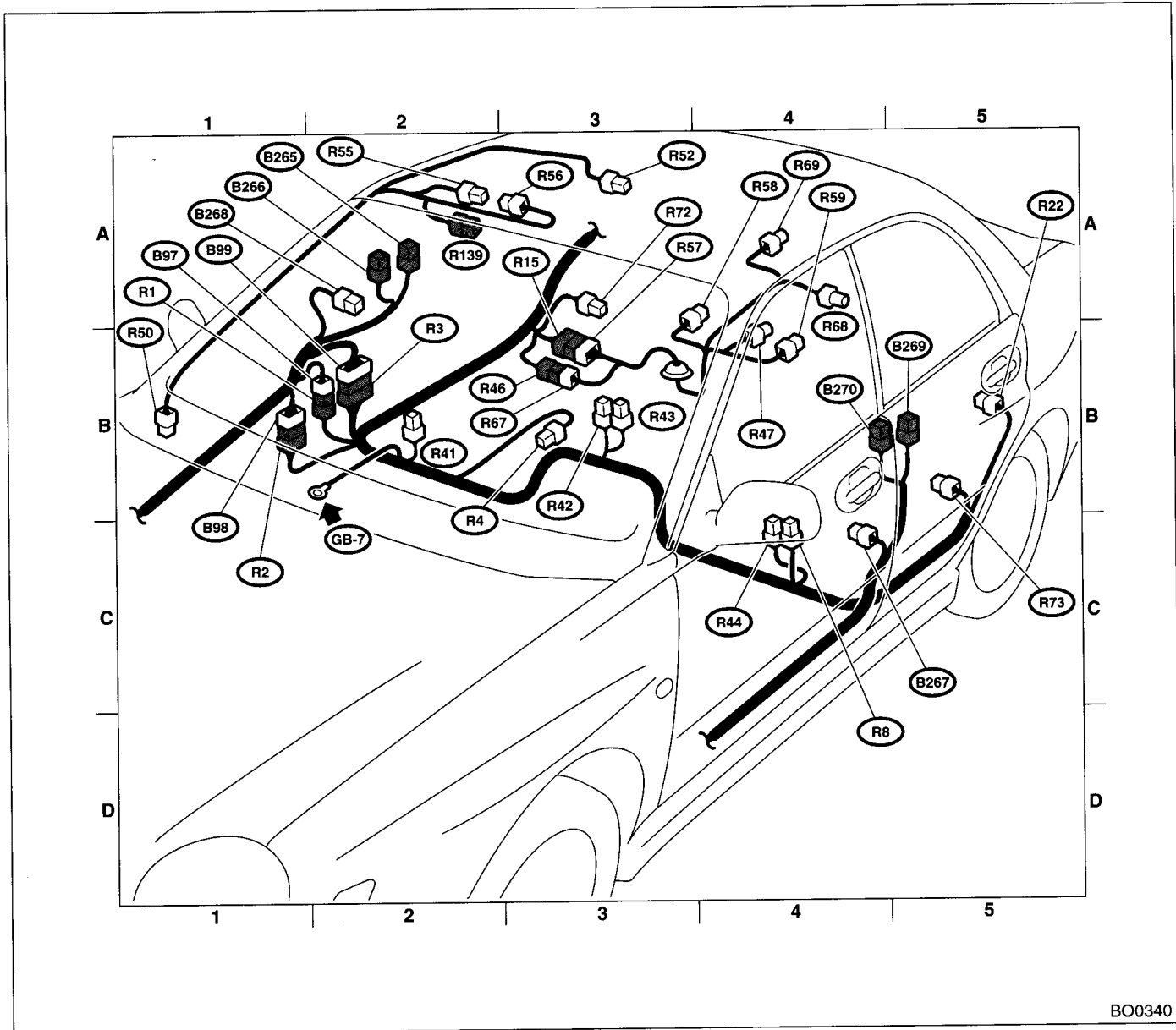

DOOR CORD

WIRING SYSTEM

52. Door Cord

A: LOCATION

Connector				Connecting to	
No.	Pole	Color	Area	No.	Name
D1	25	★	D-3	B30	Bulkhead wiring harness
D2	2	★	D-4		Front door speaker LH
D3	2	Black	C-4		Front power window motor LH
D4	2	★	C-4		Front door tweeter LH
D5	6	★	C-3		Remote control rearview mirror LH (Without mirror heater model)
	8	Black	C-3		Remote control rearview mirror LH (With mirror heater model)
D7	16	★	C-4		Power window main switch
D11	25	★	C-1	B101	Bulkhead wiring harness
D12	2	★	C-1		Front door speaker RH
D13	2	Black	B-2		Front power window motor RH
D14	2	★	B-1		Front door tweeter RH
D15	6	★	B-1		Remote control rearview mirror RH (Without mirror heater model)
	8	Black	B-1		Remote control rearview mirror RH (With mirror heater model)
D17	8	★	B-2		Front power window sub switch RH
D18	4	★	B-2		Front door lock actuator RH
D21	4	★	C-4	B269	Bulkhead wiring harness
D22	3	★	C-4	B270	
D23	2	★	C-5		Rear door speaker LH
D24	2	Black	B-4		Rear power window motor LH
D25	8	★	B-5		Rear power window sub switch LH
D26	4	★	B-5		Rear door lock actuator LH
D27	4	★	B-2	B265	Bulkhead wiring harness
D28	3	★	B-2	B266	
D29	2	★	B-2		Rear door speaker RH
D30	2	Black	A-2		Rear power window motor RH
D31	8	★	A-2		Rear power window sub switch RH
D32	4	★	A-3		Rear door lock actuator RH
D62	5	★	B-2		Front door lock switch RH
D72	4	★	C-4		Front door lock actuator LH

★: Non-colored

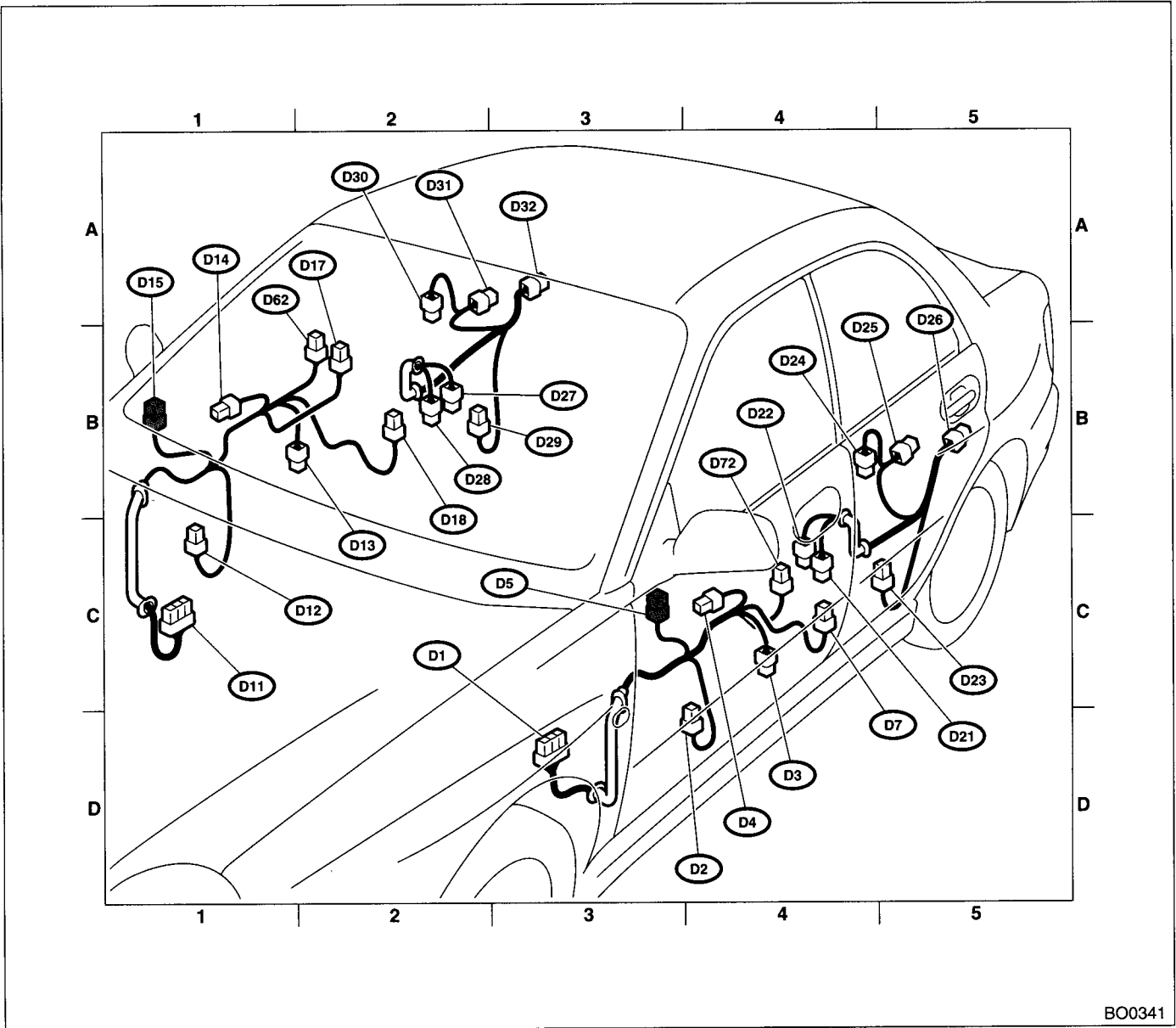

BO0341

REAR WIRING HARNESS AND TRUNK LID CORD

WIRING SYSTEM

53. Rear Wiring Harness and Trunk Lid Cord

A: LOCATION

Connector				Connecting to	
No.	Pole	Color	Area	No.	Name
R16	3	★	C-5		Rear door switch RH
R17	1	★	B-4		Rear defogger (Power)
R19	2	Blue	B-3		High-mounted stop light
R20	2	Black	B-3		Trunk room light
R24	2	★	B-4	R60	Trunk lid cord
R26	6	★	C-3		Rear combination light RH
R27	2	★	C-2		Trunk room light switch
R28	6	★	B-1		Rear combination light LH
R60	2	★	B-4	R24	Rear wiring harness
R63	2	★	C-2		License plate light
R65	1	★	A-2		Rear defogger (Ground)
R66	2	Black	C-4		High-mounted stop light (Rear spoiler)
R122	10	★	C-4		Fuel pump controller (Turbo engine model)

★: Non-colored

REAR WIRING HARNESS AND TRUNK LID CORD

WIRING SYSTEM

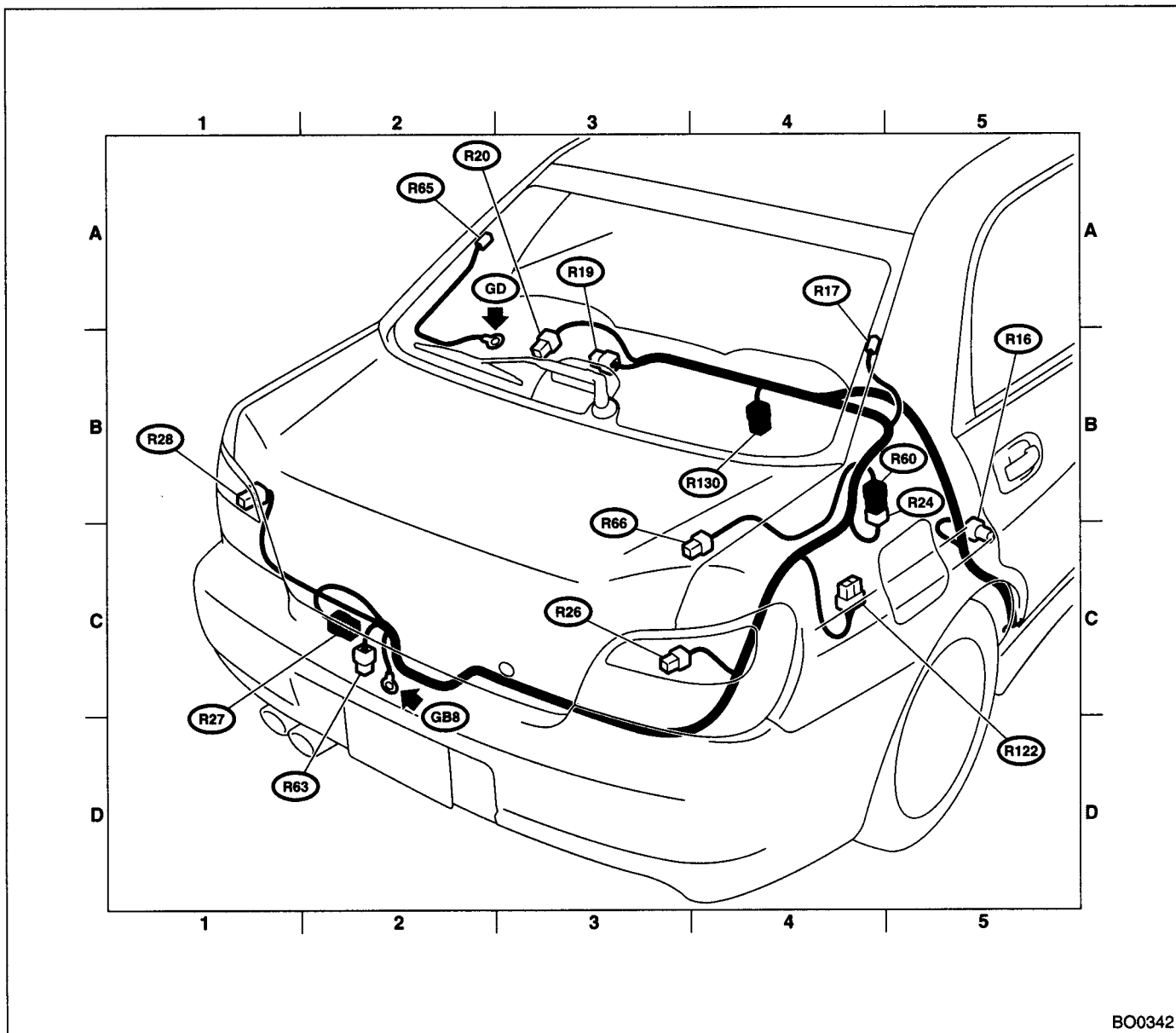

BO0342

REAR WIRING HARNESS AND REAR GATE CORD

WIRING SYSTEM

54.Rear Wiring Harness and Rear Gate Cord

A: LOCATION

Connector				Connecting to	
No.	Pole	Color	Area	No.	Name
R16	3	★	C-5		Rear door switch RH
R26	6	★	C-4		Rear combination light RH
R28	6	★	C-1		Rear combination light LH
R29	2	★	D-3		Diode (Luggage room light-2)
R30	2	★	D-3		Diode (Luggage room light-1)
R32	2	★	C-3		Rear accessory power supply socket
R38	6	★	D-4	D34	Rear gate cord
R39	4	★	D-4	D35	
R63	2	Black	D-2		License plate light
R79	6	★	D-3		Trailer connector
R116	8	★	C-4		Rear wiper intermittent module
R122	10	★	C-4		Fuel pump controller (Turbo engine model)
R141	2	★	C-3		Luggage room light

★: Non-colored

Connector				Connecting to	
No.	Pole	Color	Area	No.	Name
D34	6	★	D-4	R38	Rear wiring harness
D35	4	★	D-4	R39	
D39	2	★	B-3		High-mounted stop light
D40	1	★	A-4		Rear defogger (Power-without choke coil model)
D43	4	★	A-2		Rear wiper motor
D46	2	★	A-2		Rear gate latch switch
D47	2	★	A-3		Rear gate lock actuator cord
D48	1	★	A-2		Rear defogger (Ground-without choke coil model)
D74	2	★	A-4		Rear defogger choke coil (With choke coil model)
D76	1	★	A-3	D77	Rear defogger cord (Power-without choke coil model)
D77	1	★	A-3	D76	Rear gate cord
D78	1	Black	A-2	D79	Rear defogger cord (Ground-without choke coil model)
D79	1	Black	A-2	D78	Rear gate cord

★: Non-colored

REAR WIRING HARNESS AND REAR GATE CORD

WIRING SYSTEM

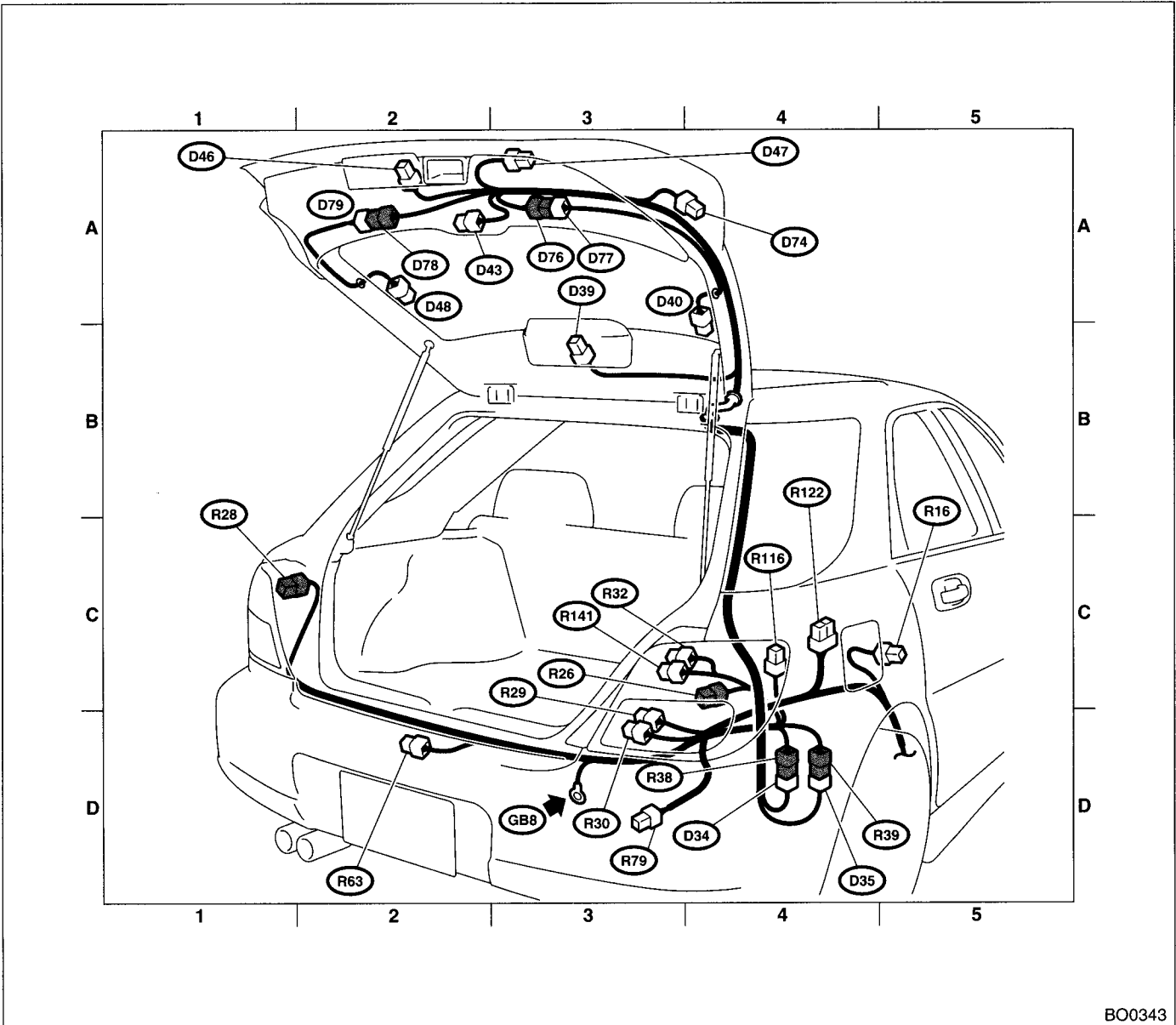

BO0343

REAR WIRING HARNESS AND REAR GATE CORD

WIRING SYSTEM
