

## 18. Camshaft

### A: REMOVAL

- 1) Remove the V-belt. <Ref. to ME(STi)-41, REMOVAL, V-belt.>
- 2) Remove the crankshaft pulley. <Ref. to ME(STi)-44, REMOVAL, Crankshaft Pulley.>
- 3) Remove the timing belt cover. <Ref. to ME(STi)-45, REMOVAL, Timing Belt Cover.>
- 4) Remove the timing belt assembly. <Ref. to ME(STi)-46, REMOVAL, Timing Belt Assembly.>
- 5) Remove the camshaft sprocket. <Ref. to ME(STi)-44, REMOVAL, Crankshaft Pulley.>
- 6) Remove the crankshaft sprocket. <Ref. to ME(STi)-56, REMOVAL, Crankshaft Sprocket.>
- 7) Disconnect the variable valve timing solenoid valve assembly connector.

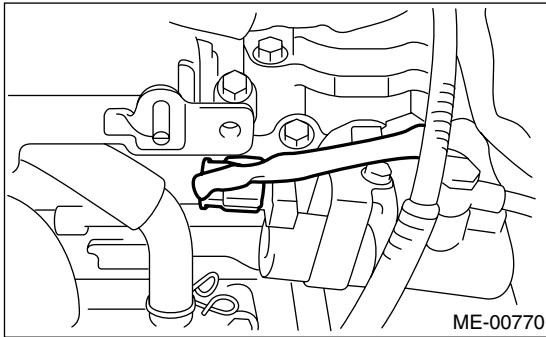

- 8) Remove the tensioner bracket.

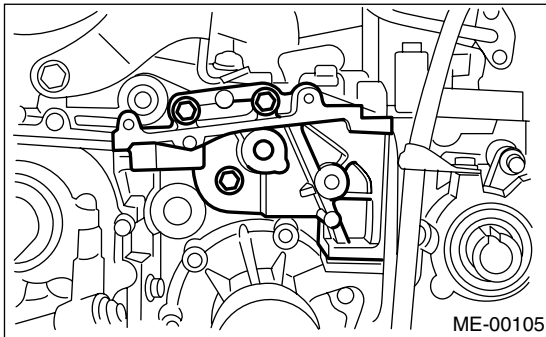

- 9) Remove the timing belt cover No. 2 (LH).

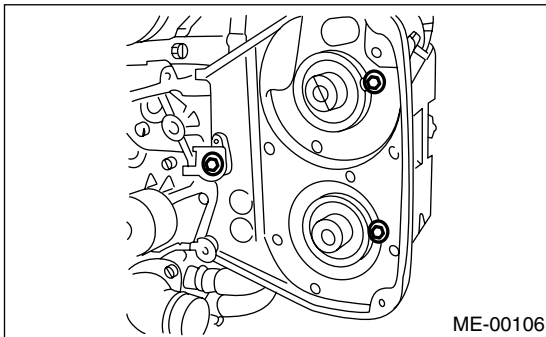

- 10) Remove the timing belt cover No.2 (RH).

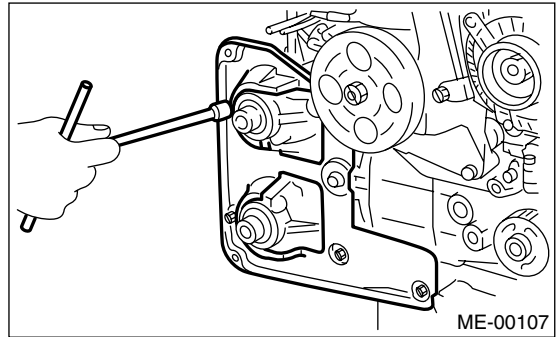

- 11) Remove the spark plug cord.
- 12) Remove the oil level gauge guide. (LH side)
- 13) Remove the rocker cover and gasket.
- 14) Remove the oil pipe.

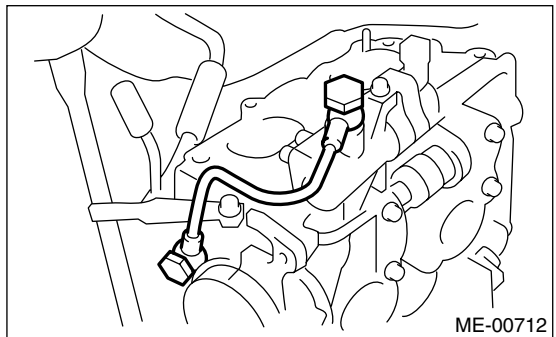

- 15) Loosen the variable valve timing solenoid valve assembly and intake camshaft cap bolts equally, a little at a time in alphabetical sequence shown in the figure.

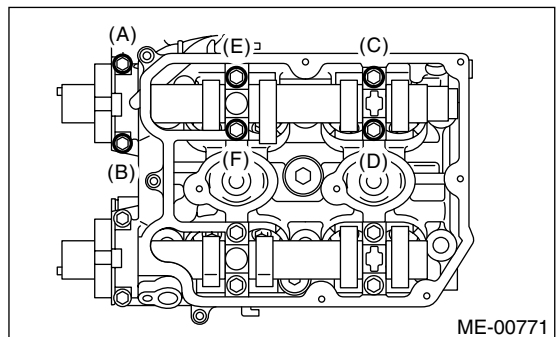

- 16) Remove the variable valve timing solenoid valve assembly, intake camshaft cap, and camshaft.

# CAMSHAFT

## MECHANICAL

17) Loosen the exhaust camshaft cap bolts equally, a little at a time in alphabetical sequence shown in the figure.

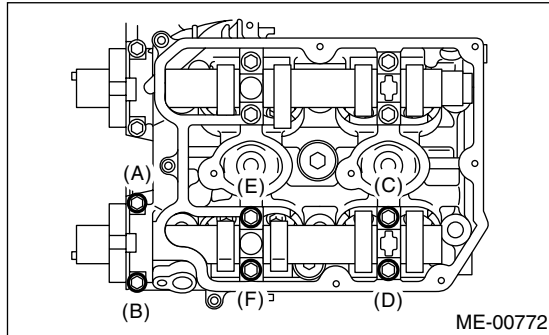

18) Remove the exhaust camshaft cap and camshaft.

### NOTE:

Arrange the camshaft caps in order so that they can be installed in their original positions.

19) Similarly, remove the camshafts (RH) and related parts.

## B: INSTALLATION

1) Camshaft installation:

Apply engine oil to cylinder head at camshaft bearing location before installing the camshaft. Install the camshaft so that each valve is close to or in contact with "base circle" of cam lobe.

### NOTE:

- When the camshafts are positioned as shown in the figure, camshafts need to be rotated at a minimum to align with the timing belt during installation.

- Camshaft (RH) need not be rotated when set at position shown in the figure.  
Intake camshaft (LH): Rotate 80° clockwise.  
Exhaust camshaft (LH): Rotate 45° counterclockwise.

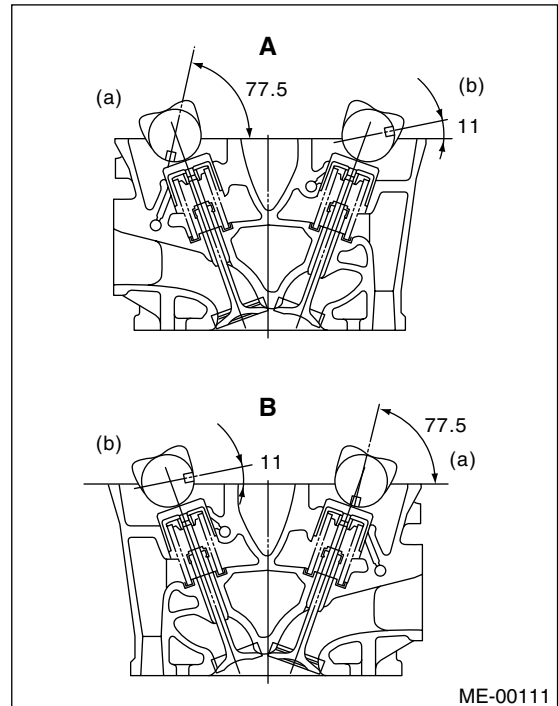

- A Cylinder head (LH)
- B Cylinder head (RH)
- (a) Intake camshaft
- (b) Exhaust camshaft

2) Camshaft cap and variable valve timing solenoid valve assembly installation:

(1) Apply fluid packing sparingly to cap mating surface.

### NOTE:

Do not apply fluid packing excessively. Failure to do so may cause excess packing to come out and flow toward the oil seal, resulting in oil leaks.

### Fluid packing:

Part No. 004403007

**THREE BOND 1215 or equivalent**

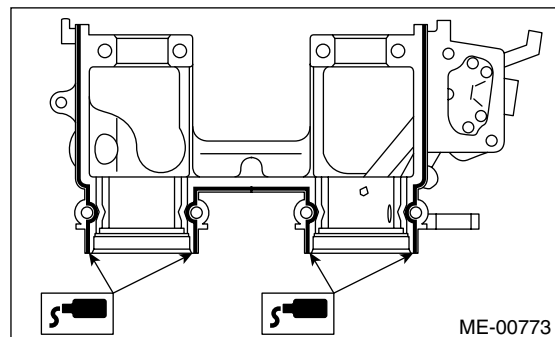

(2) Apply engine oil to cap bearing surface and install the cap on camshaft as shown by identification mark (A).

(3) Gradually tighten the camshaft cap and oil control valve assembly in at least two stages in alphabetical sequence shown in the figure, and then tighten to specified torque.

**Tightening torque:**

**T1: 10 N·m (1.0 kgf-m, 7 ft-lb)**

**T2: 20 N·m (2.0 kgf-m, 14.5 ft-lb)**

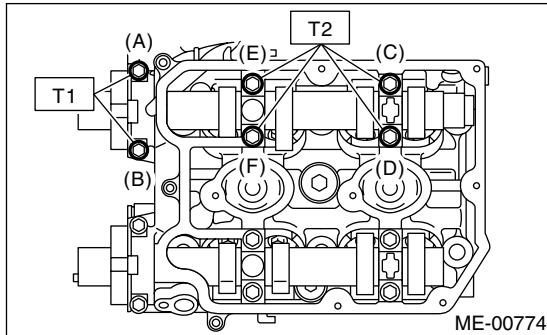

(4) Similarly, tighten cap on the exhaust side. After tightening cap, ensure the camshaft rotates only slightly while holding it at “base” circle.

**Tightening torque:**

**T1: 10 N·m (1.0 kgf-m, 7 ft-lb)**

**T2: 20 N·m (2.0 kgf-m, 14.5 ft-lb)**

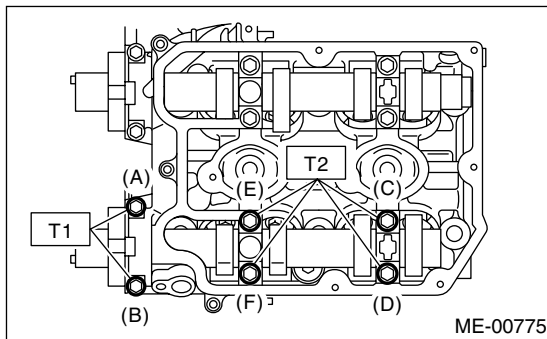

3) Camshaft oil seal installation:  
Apply grease to new oil seal lips and press onto front end of camshaft by using ST1 and ST2.

NOTE:  
Use a new oil seal.

ST1 499587600 OIL SEAL GUIDE

ST2 499597200 OIL SEAL GUIDE

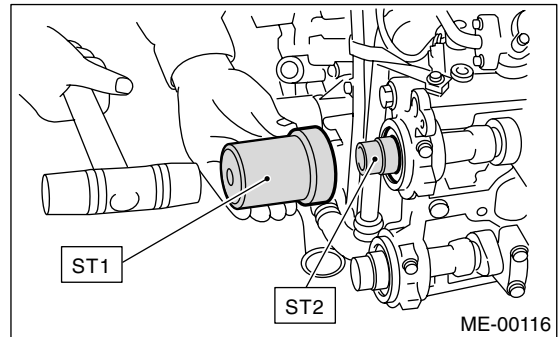

4) Rocker cover installation:

(1) Install the gasket on rocker cover.

Install the peripheral gasket and ignition coil gasket.

(2) Apply fluid packing to the specified point of cylinder head.

**Fluid packing:**

**Part No. 004403007**

**THREE BOND 1215 or equivalent**

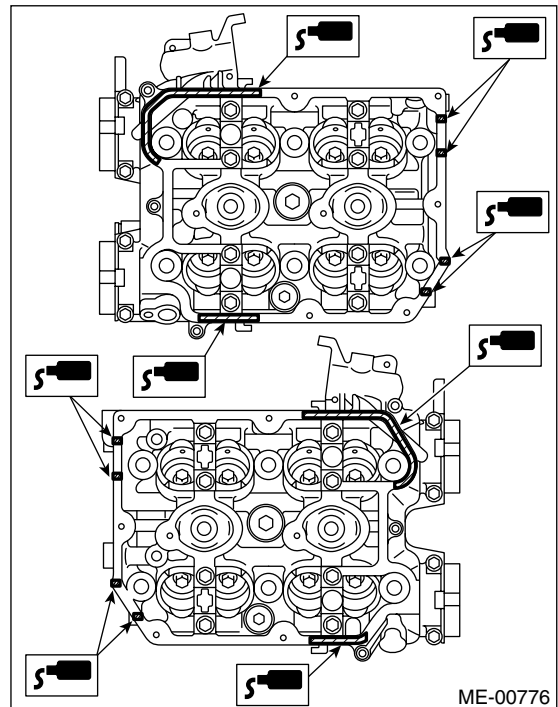

(3) Install the rocker cover on cylinder head. Ensure the gasket is properly positioned during installation.

(4) Tighten the rocker cover tightening bolt in alphabetical sequence shown in the figure, and then tighten to specified torque.

# CAMSHAFT

## MECHANICAL

### Tightening torque:

**6.4 N·m (0.65 kgf-m, 4.7 ft-lb)**

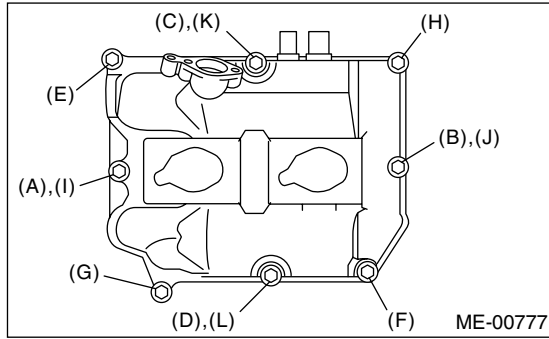

5) Install the oil pipe.

### Tightening torque:

**29 N·m (3.0 kgf-m, 21.4 ft-lb)**

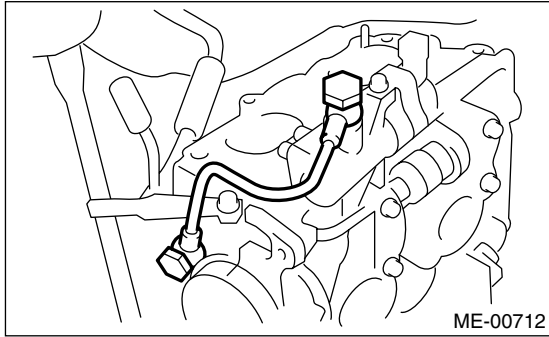

6) Connect the variable valve timing solenoid valve connector.

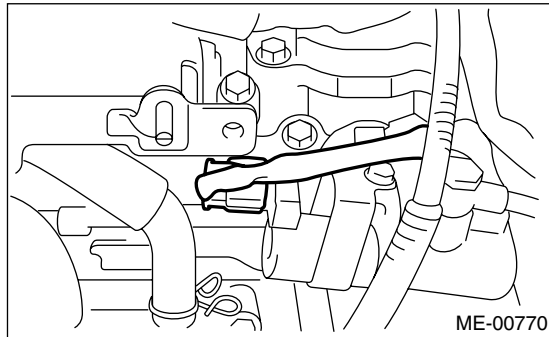

7) Install the spark plug cord.

8) Similarly, install the parts on right-hand side.

9) Install the timing belt cover No. 2 (RH).

### Tightening torque:

**5 N·m (0.5 kgf-m, 3.6 ft-lb)**

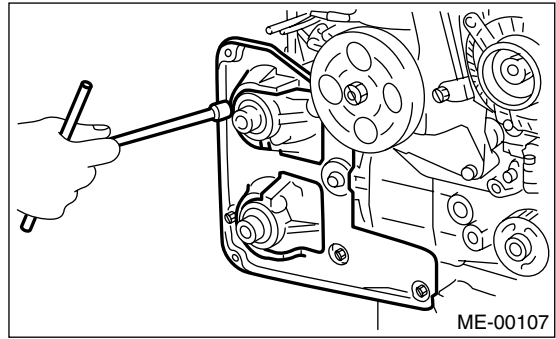

10) Install the timing belt cover No. 2 (LH).

### Tightening torque:

**5 N·m (0.5 kgf-m, 3.6 ft-lb)**

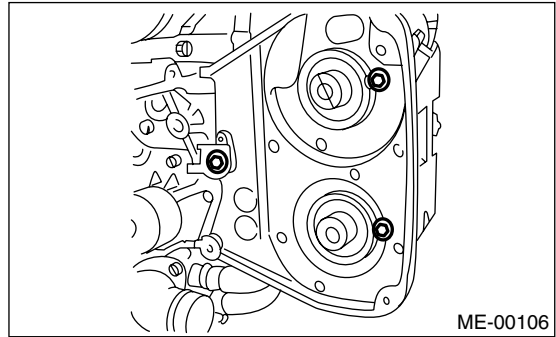

11) Install the tensioner bracket.

### Tightening torque:

**25 N·m (2.5 kgf-m, 18.1 ft-lb)**

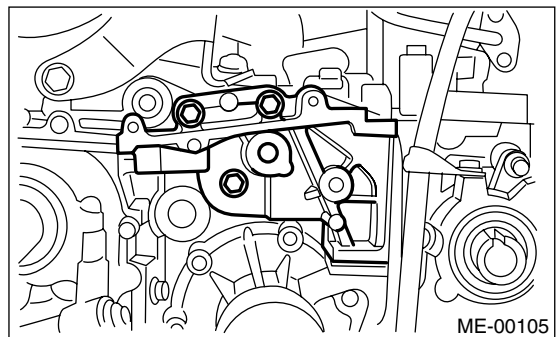

12) Install the crankshaft sprocket. <Ref. to ME(STi)-56, INSTALLATION, Crankshaft Sprocket.>

13) Install the camshaft sprockets. <Ref. to ME(STi)-54, INSTALLATION, Camshaft Sprocket.>

14) Install the timing belt assembly. <Ref. to ME(STi)-48, INSTALLATION, Timing Belt Assembly.>

15) Install the timing belt cover. <Ref. to ME(STi)-45, INSTALLATION, Timing Belt Cover.>

16) Install the crankshaft pulley. <Ref. to ME(STi)-44, INSTALLATION, Crankshaft Pulley.>

17) Install the V-belt. <Ref. to ME(STi)-41, INSTALLATION, V-belt.>

## C: INSPECTION

1) Measure the bend, and repair or replace if necessary.

**Limit:**

**0.020 mm (0.0008 in)**

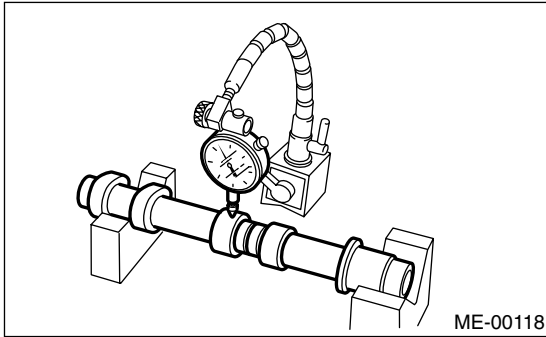

2) Check the journal for damage and wear. Replace if faulty.

3) Measure the outside diameter of camshaft journal. If the journal diameter is not as specified, check the oil clearance.

	Camshaft journal	
	Front	Center, rear
Standard	37.946 — 37.963 mm (1.4939 — 1.4946 in)	29.946 — 29.963 mm (1.1790 — 1.1796 in)

4) Measurement of the camshaft journal oil clearance:

- (1) Clean the bearing caps and camshaft journals.
- (2) Place the camshafts on cylinder head. (Without installing the valve rocker.)
- (3) Place a plastigauge across each of the camshaft journals.
- (4) Gradually tighten the cap in at least two stages in alphabetical sequence shown in the figure, and then tighten to specified torque. Do not turn the camshaft.

**Tightening torque:**

**T1: 10 N·m (1.0 kgf·m, 7.2 ft·lb)**

**T2: 20 N·m (2.0 kgf·m, 14.5 ft·lb)**

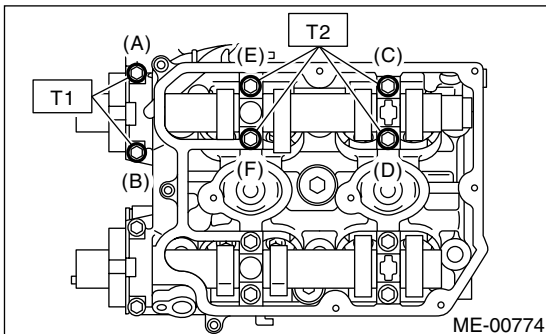

(5) Remove the bearing caps.

(6) Measure the widest point of plastigauge on each journal.

If the oil clearance exceeds the limit, replace the camshaft. If necessary, replace the camshaft caps and cylinder head as a set.

**Standard:**

**0.037 — 0.072 mm (0.0015 — 0.0028 in)**

**Limit:**

**0.10 mm (0.0039 in)**

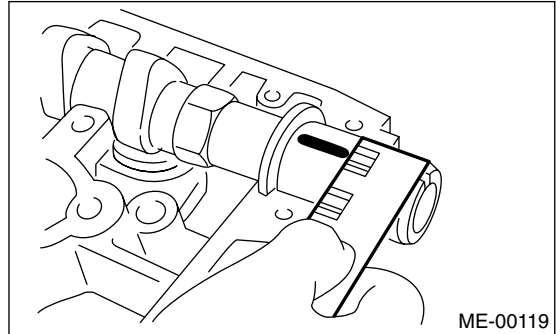

(7) Completely remove the plastigauge.

5) Check the cam face condition; remove the minor faults by grinding with oil stone. Measure the cam height H, replace if the limit has been exceeded.

**Cam height: H**

**Standard:**

**Intake:**

**46.55 — 46.65 mm (1.833 — 1.837 in)**

**Exhaust:**

**46.75 — 46.85 mm (1.841 — 1.844 in)**

**Limit:**

**Intake:**

**46.45 mm (1.829 in)**

**Exhaust:**

**46.65 mm (1.837 in)**

**Cam base circle diameter A:**

**37.0 mm (1.457 in)**

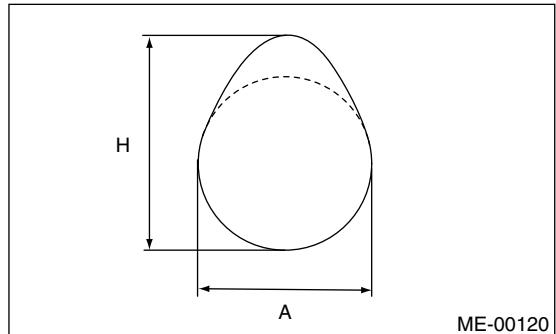

# CAMSHAFT

## MECHANICAL

---

6) Measure the thrust clearance of camshaft with dial gauge. If the clearance exceeds the limit, replace the caps and cylinder head as a set. If necessary, replace the camshaft.

**Standard:**

***0.068 — 0.116 mm (0.0027 — 0.0046 in)***

**Limit:**

***0.14 mm (0.0055 in)***

